

PB-RL30-21

Patent  
Pending



# RELOADER

Model RL30-30

## Owner / Operator's Manual



## 1.0 IMPORTANT INFORMATION

The reloader serial number plate is located behind the front left upright.

Please enter the model, serial number and additional information in the space provided for future reference.



Reloader  
Serial Number

Model No. \_\_\_\_\_

Reloader Serial No. \_\_\_\_\_

Date of Purchase \_\_\_\_\_

Dealership \_\_\_\_\_

Dealership Phone No. \_\_\_\_\_

Always use your serial number when requesting information or when ordering parts.

### HOW TO READ YOUR SERIAL NUMBER

#### RELOADER

EXAMPLE: 21RL201

Model Year / Reloader / Sequence Of Build



21



RL



201

---

Meyer Manufacturing Corporation  
674 W. Business Cty Rd A  
Dorchester, WI 54425  
Phone: 1-800-325-9103  
Fax: 715-654-5513  
Email: [parts@meyermfg.com](mailto:parts@meyermfg.com)  
Website: [www.meyermfg.com](http://www.meyermfg.com)



## 2.0 PRE-DELIVERY & DELIVERY CHECK LIST

Reloader Check List

### Meyer Manufacturing Corporation

Phone: 715-654-5132 • Toll-Free: 1-800-325-9103 • P.O. Box 405 • Dorchester, WI 54425

This Pre-Delivery & Delivery Check List must be gone through by the Selling Party and the Customer to validate the Owner's Registration Form.

#### PRE-DELIVERY CHECK LIST

After the new Meyer Reloader has been completely set-up, check to be certain it is in correct running order before delivering it to the customer.

The following is a list of points to inspect:

**Check off each item as you have made the proper adjustments and found the item operating satisfactorily. Any adjustments made, MUST be according to specifications defined in this manual.**

- All shields and guards are in place and securely fastened.
- All bolts and other fasteners are secure and tight.
- All mechanisms operate trouble free.
- All grease fittings have been lubricated, gear boxes filled to proper levels, and all roller chains are oiled. See "Lubrication" section of this manual.
- Main Apron Chains are at proper tension. See "Adjustments" section in this manual.
- All decals are in place and legible.
- All stop/tail/turn lights work properly.
- No hydraulic leaks.
- Both emergency stops work properly in both manual and remote modes.

#### DELIVERY CHECK LIST

The following check list is an important reminder of valuable information that **MUST** be passed on to the customer at the time the unit is delivered.

**Check off each item as you explain it to the customer.**

- Explain to the customer that pre-delivery check list was fully completed.
- Give customer the Owner & Operator's Manual. Instruct to read and completely understand its contents **BEFORE** attempting to operate the Reloader.
- Explain and review with customer the new Meyer Reloader manufacturer's warranty.
- Show the customer where to find the serial number on the implement.
- Explain and review with the customer "Safety Precautions" section of this manual.
- Explain and review with customer the proper "Start-up and Operating Procedures" sections of this manual.
- Demonstrate the start-up & shutdown controls, proper hydraulic hose storage and tip holder used to keep system clean from contaminants.
- Explain that regular lubrication and proper adjustments are required for continued proper operation and long life of the Reloader. Review with the customer the "Lubrication" and "Adjustments" sections of this manual.
- Explain the importance of apron chain tension, and the need to watch and tighten during the break in period.
- Fully complete this "PRE-DELIVERY & DELIVERY CHECK LIST" with the customer.



**Meyer Manufacturing Corporation**

674 W. Business Cty Rd A

Dorchester, WI 54425

Phone: 1-800-325-9103

Fax: 715-654-5513

Email: [parts@meyermfg.com](mailto:parts@meyermfg.com)

Website: [www.meyermfg.com](http://www.meyermfg.com)

**FARM EQUIPMENT BUYERS TRUST THE NAME MEYER!**

### 3.0 INTRODUCTION

*Congratulations on your purchase of a new Meyer farm equipment product. Undoubtedly you have given much consideration to your purchase and we're proud that you have selected Meyer. Pride in craftsmanship, engineering and customer service have made Meyer products the finest in the farm equipment industry today.*

*There is no substitute for quality. That is why thousands of people like you have purchased Meyer farm equipment. They felt it was the best equipment to serve their farming needs, now and in years to come. We ask that you follow our policy of "safety first", and we strongly suggest that you read through the "Owner / Operator's Manual" before operating your Meyer farm equipment. Meyer Manufacturing Corporation wants to thank you for not compromising quality. We are determined to offer excellence in customer service as well as provide you with the very best value for your dollar.*

*Sincerely,*

*All Employees of*

*MEYER MANUFACTURING CORPORATION*

---

The Model RL30-30 may be referred to as reloader, unloader, or transfer box in this manual.



**IMPORTANT:** You are urged to study this manual and follow the instructions carefully. Your efforts will be repaid in better operation and service as well as a savings in time and repair expense. Failure to read this manual and understand the machine could lead to serious injury. If you do not understand instructions in this manual, contact either your dealer or Meyer Manufacturing Corp. in Dorchester, WI.



**WARRANTY:** At the front of this manual is an "Owner's Registration Form". Be sure your dealer has completed this form and promptly forwarded a copy to Meyer Manufacturing to validate the manufacturer's warranty. The product model and serial number are recorded on this form and on the inside of the front cover for proper identification of your Meyer Reloader by your dealer and the manufacturer when ordering repair parts. The serial number is riveted on behind the front upright on the left-hand side.



**REPAIR PARTS:** At the back of this manual is the repair parts section. All replacement parts are to be obtained from or ordered through your Meyer dealership. When ordering repair parts, refer to the parts section and give complete information including quantity, correct part number, detailed description and even model and serial numbers of the reloader which needs repair parts.

**Manufacturer's Statement:** Meyer Manufacturing Corporation reserves the right to make improvements in design, or changes in specifications at any time, without incurring any obligation to owners of units previously sold. This supersedes all previous published instructions.

**FEATURES**

<b>DESCRIPTION</b>	<b>RL30-30</b>
Clad-Tuff Fiberglass Woven Side Panels	STD
Solid Poly Floor - High Molecular	STD
Hydraulic Drive	STD
Rear Transport Lights - LED	STD

# TABLE OF CONTENTS

1.0	IMPORTANT INFORMATION	2
2.0	PRE-DELIVERY & DELIVERY CHECK LIST	3
3.0	INTRODUCTION	5
4.0	MANUFACTURER'S WARRANTY	9
5.0	SAFETY	11
5.1	SAFETY PRECAUTIONS	12
5.2	SAFETY SIGNS	14
5.3	SHUTOFF & LOCKOUT POWER	20
5.3.1	Shutoff & Lockout Power Recommendations	20
6.0	PRE-OPERATION	21
6.1	STATIC INSPECTION	21
6.2	PTO DRIVELINE	22
6.3	SET UP	23
6.4	OPERATIONAL CHECKS	24
6.4.1	Controls	25
6.4.1.1	Emergency Stops	25
6.4.1.2	Remote Control	25
6.4.1.3	Guide Lights	25
6.4.2	Start-Up	26
6.4.3	Shut-Down	26
6.5	TEAR DOWN	27
6.6	HYDRAULIC HOOK-UP	27
6.7	TRANSPORTING	28
6.7.1	Hitching To Tractor	29
6.7.2	Safety Chain	30
6.7.3	Tractor Towing Size Requirements	30
6.7.4	Unhooking The Tractor	31
7.0	OPERATION	33
7.1	LOADING	33
7.2	UNLOADING	34
8.0	MAINTENANCE	35
8.1	LUBRICATION	35
8.1.1	Daily Lubrication (every 8-10 hours of operation)	35
8.1.2	Weekly Lubrication (every 56-70 hours of operation)	36
8.1.3	Monthly Lubrication (every 224-280 hours of operation)	36

8.1.4 Annual Lubrication .....	38
8.1.5 Gearbox Oil Change .....	39
8.2 ADJUSTMENTS .....	40
8.2.1 Adjust Apron Chain Tension (Daily Every 8-10 Hours) .....	40
8.2.2 Adjust Wheel Bearing Preload .....	40
8.2.3 Wheels and Tires .....	41
8.3 STORING THE RELOADER .....	42
8.4 RETURNING THE RELOADER TO SERVICE .....	42
9.0 PARTS REPAIR AND REPLACEMENT .....	43
9.1 REPLACEMENT PARTS .....	43
10.0 SPECIFICATIONS .....	45
MAINTENANCE RECORD .....	47



## 4.0 MANUFACTURER'S WARRANTY

01/2019

### MEYER RELOADER

- I. The "Owner's Registration Form" must be completed in full and promptly returned to Meyer Mfg. Corp. for this warranty to become both valid and effective. All warranties on new Meyer Reloaders shall apply only to the original retail customer from an authorized Meyer Mfg. Corp. dealership.
- II. This warranty shall not apply to any Meyer Reloader which has been subjected to misuse, negligence, alteration, accident, incorrect operating procedures, has been used for an application not designed for or pre-authorized by Meyer in writing, has had the serial numbers altered, or which shall have been repaired with parts other than those obtained through Meyer Mfg. Corp. Meyer is not responsible for the following: Depreciation or damage caused by normal wear, lack of reasonable and proper maintenance, failure to follow the operator's manual recommendations or normal maintenance parts and service. Meyer is not responsible for rental of replacement equipment during warranty repairs, damage to a power unit (including but not limited to a truck or tractor), loss of earnings due to equipment down time, or damage to equipment while in transit to or from the factory or dealer.
- III. Meyer Mfg. Corp. warrants new Meyer Reloader to be free from defects in material and workmanship under recommended use and maintenance service, as stated in the "Owner / Operator's Manual", as follows:
  - A. Meyer Mfg. Corp. will repair or replace F.O.B. Dorchester, WI, as Meyer Mfg. Corp. elects, any part of a new Meyer forage box which is defective in material or workmanship:
    - i. Without charge for either parts or labor during the first (1) year from purchase date to the original retail customer.
- IV. Repairs eligible for labor warranty must be made by Meyer Mfg. Corp. or an authorized Meyer dealership. The original retail customer is responsible for the transportation of the reloader to the dealership for warranty service or for any service call expenses.
- V. Except as stated above, Meyer Mfg. Corp. shall not be liable for injuries or damages of any kind or nature, direct, consequential, or contingent, to persons or property. This warranty does not extend to loss of crop or for any other reasons.
- VI. No person is authorized to give any warranties or to assume any other obligation on Meyer Mfg. Corp.'s behalf unless made or assumed in writing by Meyer Mfg. Corp. This warranty is the sole and exclusive warranty which is applicable in connection with the manufacture and sale of this product and Meyer Mfg. Corp's responsibility is limited accordingly.
- VII. Tires, optional scales and tarps fall under the original manufacturer's warranty.



## 5.0 SAFETY

The Meyer Reloader is manufactured with operator safety in mind. Located on the reloader are various safety signs to aid in operation and warn of hazardous areas. Pay close attention to all safety signs on the reloader.

Carefully follow the operating and maintenance instructions in this manual and all applicable safety laws. Failure to follow all safety procedures may result in serious injury or death.

**Before attempting to operate this reloader, read and study the following safety information. In addition, make sure that every individual who operates or works with the reloader, whether family member or employee, is familiar with these safety precautions.**

Meyer Mfg. Corp. provides guards for exposed moving parts for the operator's protection; however, some areas cannot be guarded or shielded in order to assure proper operation. The operator's manual and safety signs on the reloader itself warn you of hazards and must be read and observed closely!

---

### Safety Alert Symbol

This symbol is used to call attention to instructions concerning personal safety. Be sure to observe and follow these instructions. Take time to be careful!

---



The signal word **DANGER** on the machine and in the manual identifies a hazardous situation which, if not avoided, WILL result in death or serious injury.



The signal word **WARNING** on the machine and in the manual indicates a potentially hazardous situation which, if not avoided, COULD result in death or serious injury.



The signal word **CAUTION** on the machine and in the manual indicates a potentially hazardous situation which, if not avoided, MAY result in minor or moderate injury. It may also be used to alert against unsafe practices.



**IMPORTANT**

This notice identifies procedures which must be followed to avoid damage to the machine.

Danger, Warning, Caution, and instructional decals and plates are placed on the equipment to protect anyone working on or around this machine, as well as the components of the machine. All personnel operating or maintaining this equipment must familiarize themselves with all Danger, Warning, Caution, and instructional decals and plates.

## 5.1 SAFETY PRECAUTIONS



**All individuals who will operate this reloader must read and completely understand this Operator's And Parts Manual. Operator must receive instructions before operating the machine. Untrained operators can cause injury or death.**

- DO NOT allow anyone to operate, service, inspect or otherwise handle this reloader until all operators have read and understood all of the instructional materials in this Operator's And Parts Manual and have been properly trained in its intended usage.
- For an operator to be qualified, he or she must not use drugs or alcohol which impair alertness or coordination while working. An operator who is taking prescription drugs must get medical advice to determine if he or she can safely operate a machine and the equipment.
- Make sure all personnel can READ and UNDERSTAND all safety signs.
- DO NOT allow minors (children) or inexperienced persons to operate this reloader.
- DO NOT operate until all shields and guards are in place and securely fastened.
- DO NOT step up on any part of the reloader at any time.
- DO NOT adjust, clean or lubricate while the reloader is in motion.
- Inspect when first delivered and regularly thereafter; that all connections and bolts are tight and secure before operating.
- Know how to stop operation of the reloader before starting it!
- Make certain everyone is clear of the reloader before applying power.
- Keep hands, feet and clothing away from moving parts. Loose or floppy clothing should not be worn by the operator.
- Observe all applicable traffic laws when transporting on public roadways (where legal to do so). Check local laws for all highway lighting and marking requirements.
- Shut off and lock out power before adjusting, servicing, maintaining or clearing an obstruction from this machine. (See 5.3 SHUTOFF & LOCKOUT POWER on page 20.)
- Always enter curves or drive up or down hills at a low speed and at a gradual steering angle.
- Never allow riders on either tractor / truck or equipment.
- Keep tractor / truck in a lower gear at all times when traveling down steep grades.
- Stay away from overhead power lines. Electrocution can occur without direct contact.
- Use only properly rated undercarriage and tires.
- Do not exceed 20 mph (32 kph). Reduce speed on rough roads and surfaces.
- Always install a SMV emblem on pull-type equipment when transporting on roadways and keep clean and bright.
- Always yield to oncoming traffic in all situations and move to the side of the road so any following traffic may pass.

**Safety Precautions For Tractor Towed Units:**

- Do not exceed 20 mph (32 kph). Reduce speed on rough roads and surfaces.
- Always install a SMV emblem on pull-type equipment when transporting on roadways and keep clean and bright.
- Always yield to oncoming traffic in all situations and move to the side of the road so any following traffic may pass.

**Safety Precautions For Hydraulic System:**

- Check hydraulic tubes, hoses and fittings for damage and leakage. Never use hands to check for leaks. Hydraulic tubes and hoses must be properly routed and have adequate support and secure clamps. Tighten or replace any parts that show leakage.
- Always clean fluid spills. Do not use gasoline or diesel fuel for cleaning parts. Use commercial nonflammable solvents.

## 5.2 SAFETY SIGNS



Read all safety signs on the Reloader and in this manual. Keep all safety signs clean and replace any damaged or missing safety signs before operating the equipment. Do Not remove any safety signs. Safety signs are for operator protection and information.

CENTER PIVOT

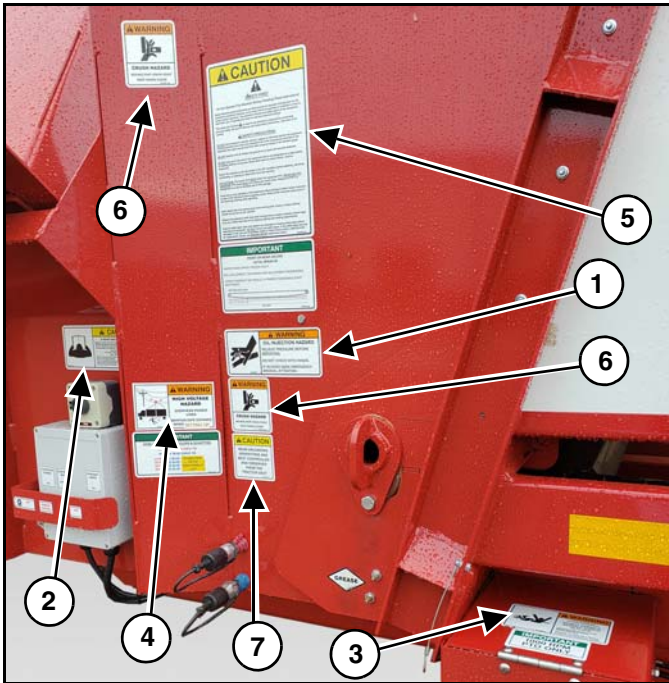

PART NO. 46-8500-7

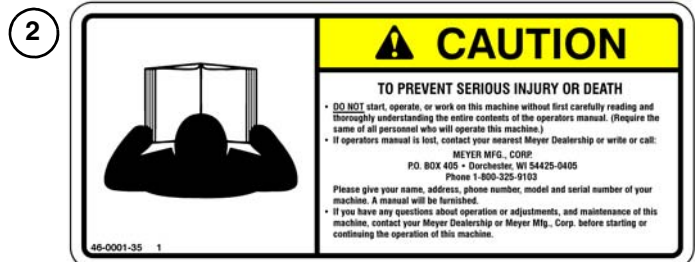

PART NO. 46-0001-35



PART NO. 46-3600-9

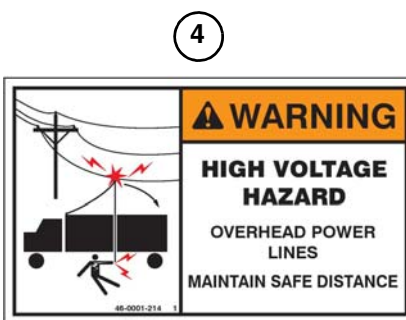

PART NO. 46-0001-214

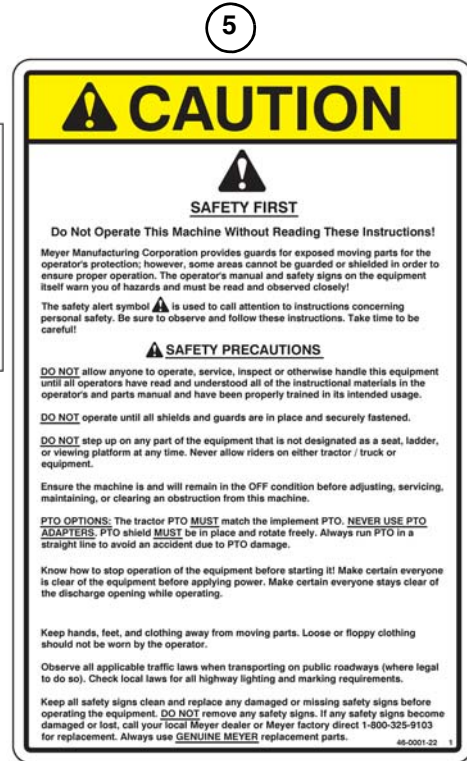

PART NO. 46-0001-22



PART NO. 46-0001-205



PART NO. 46-0001-72

FRONT LEFT OF RELOADER

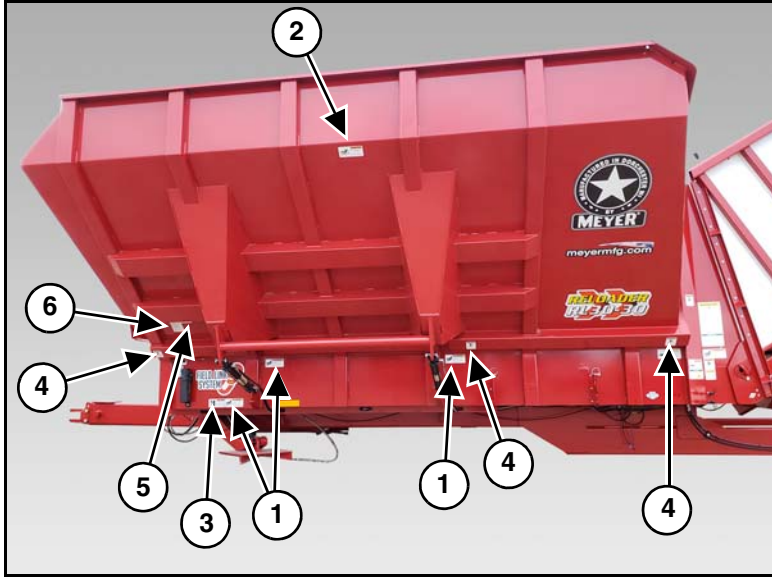

PART NO. 46-8500-7



PART NO. 46-9100-4

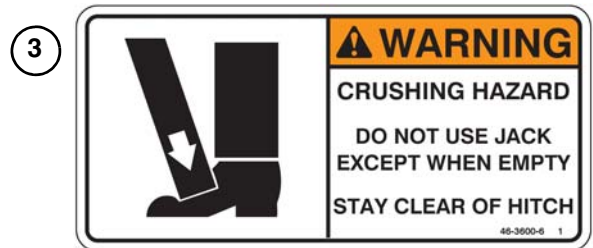

PART NO. 46-3600-6

6

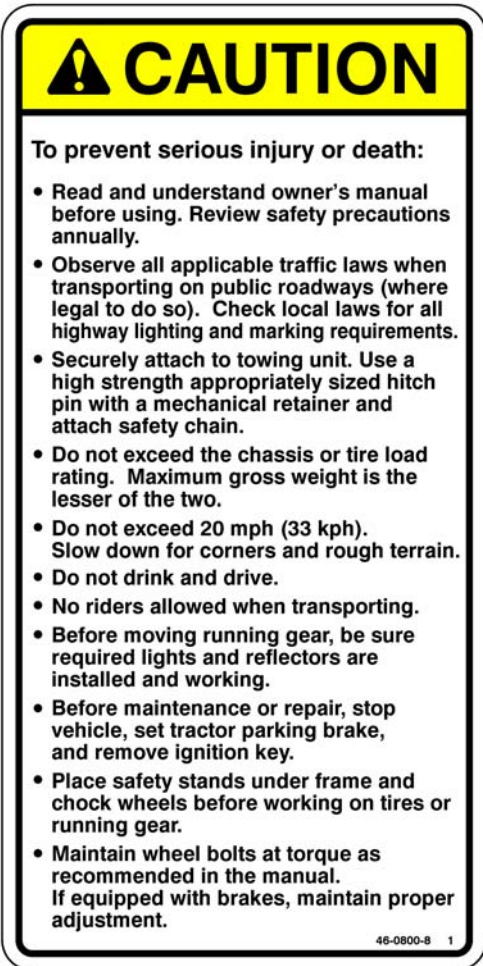

PART NO. 46-0800-8

5



PART NO. 46-0800-7

4



PART NO. 46-0001-205

FRONT

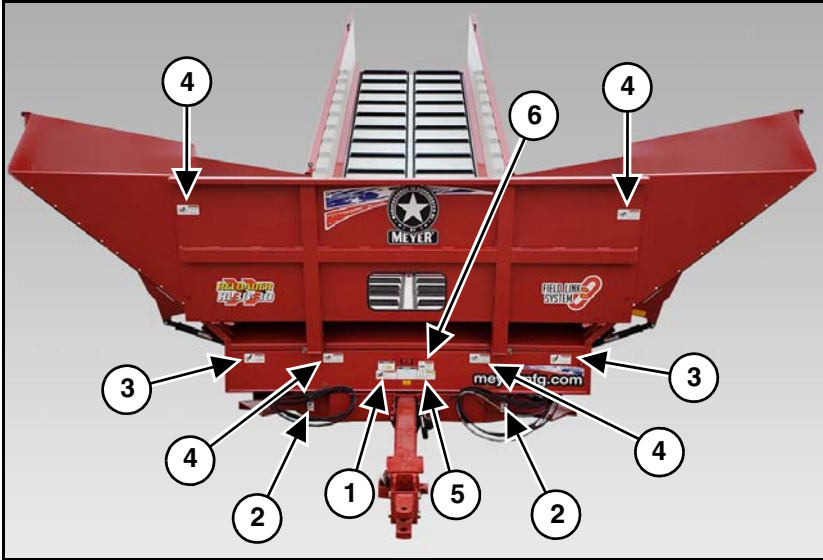

RLH SHOWN

1



PART NO. 46-8500-7

2



PART NO. 46-0001-205

3



PART NO. 46-0001-4

4



PART NO. 46-9100-4

5



PART NO. 46-0001-62

6



PART NO. 46-0001-214



RIGHT SIDE

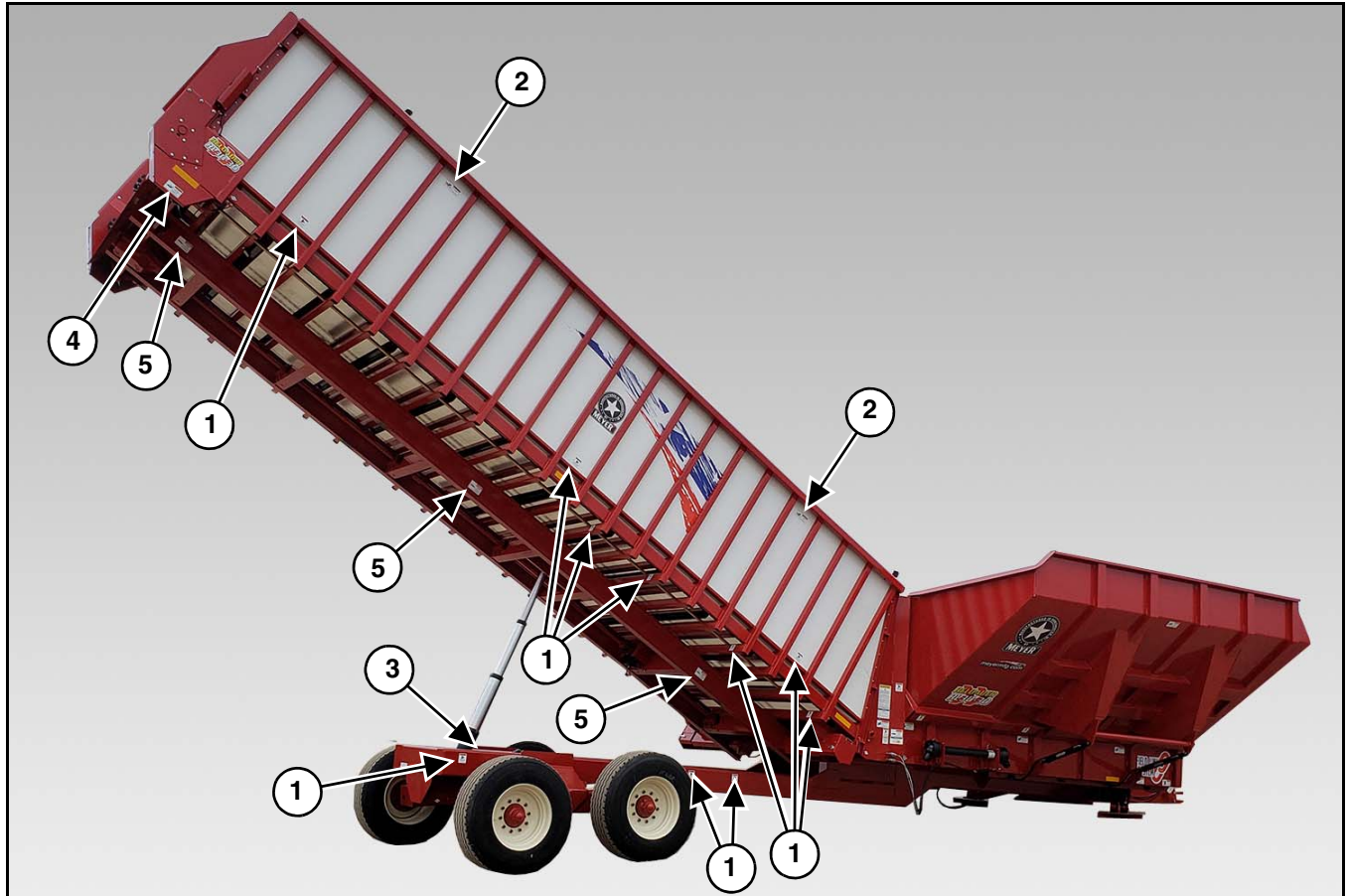

PART NO. 46-0001-205



PART NO. 46-9100-4



PART NO. 46-8500-7



PART NO. 46-3600-9

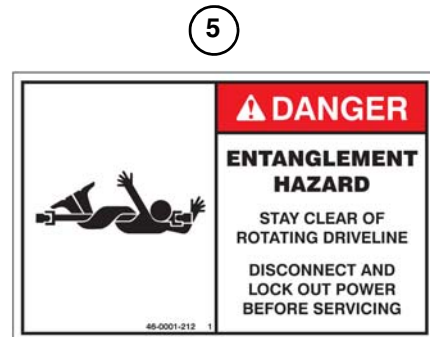

PART NO. 46-0001-212

REAR



1



PART NO. 46-0001-33

LEFT SIDE



1



PART NO. 46-0001-205

2



PART NO. 46-9100-4

3



PART NO. 46-8500-7

4



PART NO. 46-0001-212

5



PART NO. 46-3600-9

## 5.3 SHUTOFF & LOCKOUT POWER



Any individual that will be adjusting, servicing, maintaining, or clearing an obstruction from this machine needs to ensure that this machine stays safely “OFF” until the adjustment, service, or maintenance has been completed, or when the obstruction has been cleared, and that all guards, shields, and covers have been restored to their original position. The safety of all individuals working on or around this machine, including family members, are affected. The following procedure will be referred to throughout this manual, so be familiar with the following steps.

### 5.3.1 Shutoff & Lockout Power Recommendations

#### 1. Think, Plan and Check

- a. **Think** through the entire procedure and identify all the steps that are required.
- b. **Plan** what personnel will be involved, what needs to be shut down, what guards / shields need to be removed, and how the equipment will be restarted.
- c. **Check** the machine over to verify all power sources and stored energy have been identified including engines, hydraulic and pneumatic systems, springs and accumulators, and suspended loads.

2. **Communicate** - Let everyone involved, including those working on or around this machine, that work is being done which involves keeping this machine safely “OFF”.

#### 3. Power Sources

- a. **LOCKOUT** - Shut off engines and take the key, or physically lock the start/on switch or control. Disconnect any power sources which are meant to be disconnected (i.e. electrical, hydraulic, and PTO of pull-type units).
- b. **TAGOUT** - Place a tag on the machine noting the reason for the power source being tagged out and what work is being done. This is particularly important if the power source is not within your sight and/or will need to be isolated for a longer period of time.

4. **Stored Energy** - Neutralize all stored energy from its power source. Ensure that this machine is level, set the parking brake, and chock the wheels. Disconnect electricity, block moveable parts, release or block spring energy, release pressure from hydraulic and pneumatic lines, and lower suspended parts to a resting position.

5. **Test** - Do a complete test and personally double check all of the above steps to verify that all of the power sources are actually disconnected and locked out.

6. **Restore Power** - When the work has been completed, follow the same basic procedures, ensuring that all individuals working on or around this machine are safely clear of the machine before locks and tags are removed and power is restored.

A green rectangular sign with the word "IMPORTANT" in bold white capital letters.

**IMPORTANT**

It is important that everyone who works on this equipment is properly trained to help ensure that they are familiar with this procedure and that they follow the steps outlined above. This manual will remind you when to Shutoff & Lockout Power.

## 6.0 PRE-OPERATION

---



### CAUTION

**DO NOT** allow anyone to operate, service, inspect or otherwise handle this reloader until all operators have read and understand all of the instructional materials in this Operator's And Parts Manual and have been properly trained in its intended usage.

**Verify that the reloader is securely fastened to the tractor.**

**Verify that all electrical / hydraulic connections and bolts / hardware are tight and securely fastened before operating the reloader.**

**Always keep all shields and guards in place and securely fastened.**

**Keep hands, feet and clothing away.**

**Wear safety glasses to prevent eye injury when any of the following conditions exist:**

- **When fluids are under pressure.**
- **Flying debris or loose material is present.**
- **Tools are being used.**

**Failure to heed may result in serious personal injury or death.**

---

### 6.1 STATIC INSPECTION



### WARNING

**Hydraulic fluid escaping under pressure can have sufficient force to cause injury. Keep all hoses and connections in good serviceable condition. Failure to heed may result in serious personal injury or death.**

Before operating the reloader for the first time and each time thereafter, check the following items:

1. Inspect the reloader for proper adjustments. (See 8.2 ADJUSTMENTS on page 40.)
2. Lubricate the equipment. (See 8.1 LUBRICATION on page 35.)
3. Make sure that all guards and shields are in place, secured and functioning as designed.
4. Check all main roller bearings for wear. Replace as needed.
5. Check condition of all hydraulic components for leaks. Repair or replace as required.
6. Check the hydraulic oil level. (See 8.1 LUBRICATION on page 35.)
7. Check to see that no obstructions are present in the reloader prior to start up.
8. Be sure that there are not tools laying on or in the reloader.
9. Inspect the trailer to verify that all connections and bolts are tight and secure before operating.
10. Make sure area is clear of people, tools, and other objects before moving trailer.
11. Check tires for proper inflation.
12. Use only properly rated tires.

## 6.2 PTO DRIVELINE



Shutoff and lockout power before performing machine service, adjusting, maintaining, or clearing an obstruction from this machine. Refer to section 5.3 SHUTOFF & LOCKOUT POWER.



Do not operate without PTO guard on implement and tractor. Maintain PTO drive shaft guards in good operating condition. Replace them if damaged and not turning freely. Failure to heed may result in serious personal injury or death.

The tractor half of the PTO drive shaft assembly must be locked securely to the tractor output shaft and the implement half of the PTO drive shaft assembly must be locked securely to the reloader driveline.

See your PTO Installation, Service, and Safety Instruction Manual for additional PTO details. For a replacement manual, call the factory at 1-800-325-9103.

See your ADMA Safety Manual for further safety situations and precautions that you should familiarize yourself and those that may be operating this equipment. For a replacement manual, call the factory at 1-800-325-9103.

### IMPORTANT

**DO NOT EXCEED THE MAXIMUM 15° ANGLE ON THE PTO DRIVELINE. EXCEEDING THE MAXIMUM ANGLE WILL EXERT EXCESSIVE PRESSURES ON THE PTO INPUT CENTER SHAFT AND RELATED BEARINGS.**

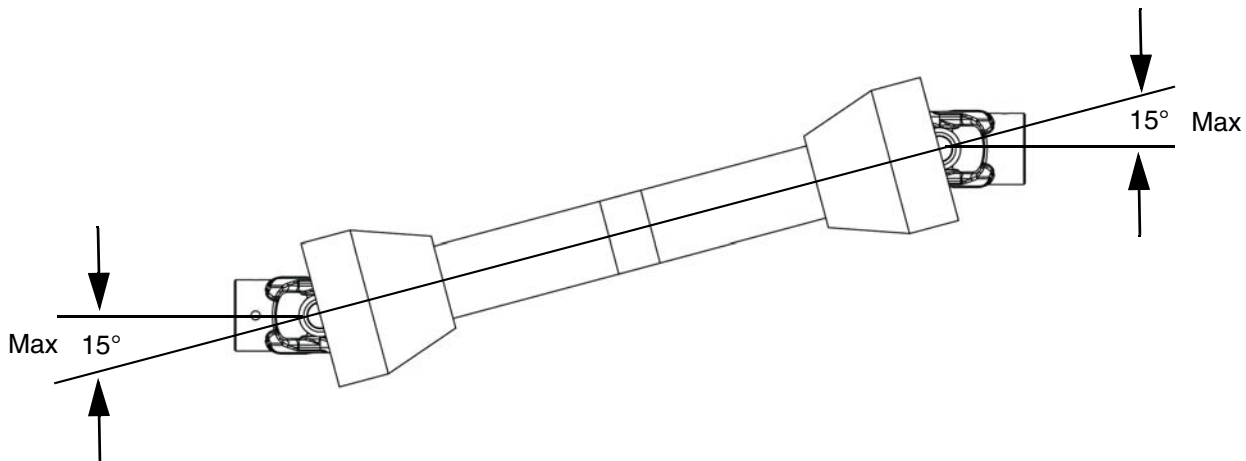

An improperly positioned tractor may cause damage to the universal joints of the PTO drive shaft. The optimal PTO driveline angle is 0 degrees and a maximum angle of 15 degrees. Do not exceed the maximum PTO length of 72 inches.

PTO PART NUMBER	A	B
18-0022	46.35	72.22
18-0023	46.35	72.22

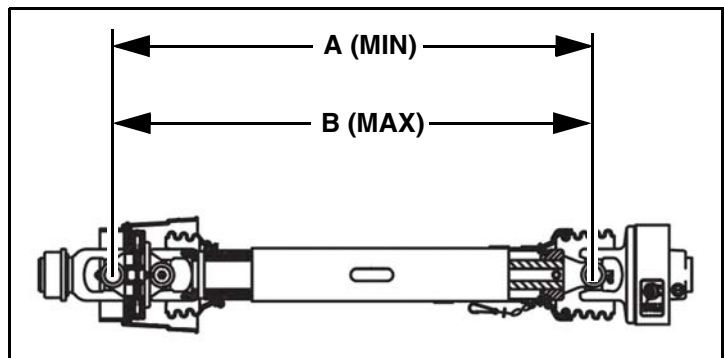

FIGURE 2. PTO DRIVELINE

### 6.3 SET UP



**WARNING**



#### To Prevent Serious Injury Or Death

- Keeps hands and body out of the hitch area when attaching towing vehicle.
- Keep body clear of crush point between towing vehicle and load.
- Keeps hands, legs and feet from under tongue and hitch until jack is locked into place.



**WARNING**

Set up reloader away from power lines.

Once the reloader is ready to be set up, follow the steps listed below:

1. Unhook the tractor (See section 6.7.4 Unhooking The Tractor.)
2. Unhook the hydraulic hoses and light cord.
3. Secure hoses and light cord into storage compartment.
4. Retract the outrigger cylinders to lower the hitch to within 1" from the ground. (Note: This keeps positive pressure on the outriggers.)
5. Park the tractor to the side of the reloader for operation.
6. Connect the hydraulic hoses to elevate the reloader into operating position.
7. Connect the power cord to the tractor.
8. Connect the PTO to the tractor.

## 6.4 OPERATIONAL CHECKS

---



### CAUTION

Shutoff and lockout power before performing machine service, adjusting, maintaining, or clearing an obstruction from this machine. Refer to section 5.3 SHUTOFF & LOCKOUT POWER.

**DO NOT** allow anyone to operate, service, inspect or otherwise handle this reloader until all operators have read and understand all of the instructional materials in this Operator's And Parts Manual and have been properly trained in its intended usage.

Before operating the reloader, look in all directions and make sure no bystanders, especially small children are in the work area.

---



### WARNING

Before operating the reloader, look in all directions and make sure no bystanders, especially small children are in the work area.

Turn the master power switch off, disengage the PTO, stop the engine and make sure all moving components are completely stopped before connecting, disconnecting, adjusting or cleaning this equipment.

**Always keep all shields and guards in place and securely fastened. Keep hands, feet and clothing away.**

---

Before running material through the reloader for the first time and each time thereafter, follow the steps listed below:

1. Locate a level and stable area to set up the reloader.
2. Follow the Setup procedure section 6.3 SET UP.
3. Follow the Start-Up procedure section 6.4.2 Start-Up.
4. Test the on/off function to make sure it is working properly, in both remote and manual modes.
5. Operate for approximately 5-10 minutes.
6. Test both emergency stops to make sure they are working properly.
7. Follow the Shut-Down procedure section 6.4.3 Shut-Down.
8. Check drive components to be sure components are not abnormally hot.
9. Check all hydraulic components for leaks.
10. Adjust and lubricate equipment as needed. (See 8.1 LUBRICATION) & (See 8.2 ADJUSTMENTS).
11. Test each unloading trailers/vehicles to make sure the guide light sensor is working properly.



### 6.4.1 Controls

A switch box is located on the driver's side of the reloader. There are 4 switches, one to turn the conveyor system on/off (Key 1), one to choose manual or remote mode (Key 2), one to turn on the guide lights (Key 3) (optional), and one to turn the bunk lights on/off (Key 4). If power is lost for any reason the start button (Key 5) will need to be pressed to restart.

#### 6.4.1.1 Emergency Stops

There are two emergency stops located on either side of the loading hopper. To stop the conveyor, press the emergency stop button. To reset twist and pull the emergency stop button out, and then press the start button.

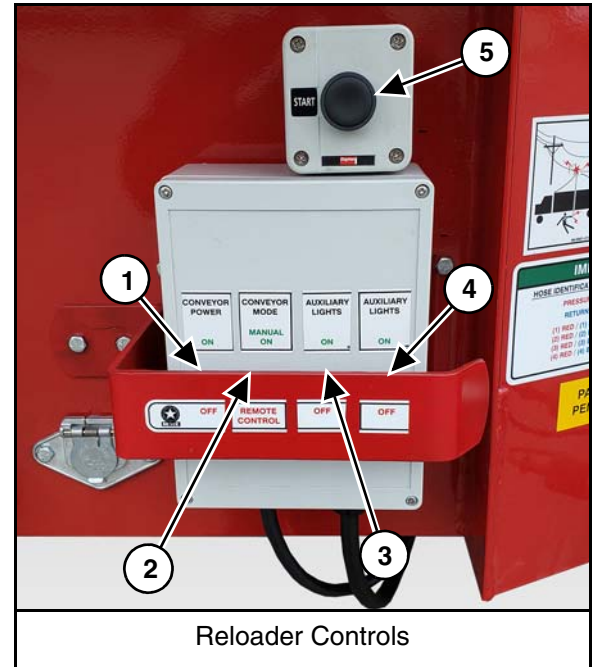

#### 6.4.1.2 Remote Control



**Make sure remote controls are charged and are working properly. Replace as needed.**

A remote control is provided with the reloader. There are 2 switches, one to turn the conveyor system on/off (Key 6) and one to turn the bunk lights on/off (Key 7). Turn the master conveyor power switch on, select remote mode and initially the start button will need to be pressed to turn the conveyor on/off using the remote control.

**NOTE: Use the provided remote control charger to keep the remote control charged.**

#### 6.4.1.3 Guide Lights

The sensor control will turn the red guide lights off when the unloading vehicle has backed into the reloader to the proper distance to discharge the load.



### **6.4.2 Start-Up**

1. Verify that the reloader is setup correctly (See section 6.3 SET UP.)
2. Enter the tractor and verify it is in park.
3. Start the engine.
4. Run the tractor at idle speed.
5. Slowly engage the hydraulics and operate at idle speed to ensure the reloader is operating properly.
6. Accelerate the tractor to 680 RPM PTO speed.
7. Turn master conveyor power switch to on.
8. Press the start button.
9. Turn the conveyor on with the remote control function.

### **6.4.3 Shut-Down**

1. Make sure all material has been discharged from the reloader.
2. Turn the conveyor off with the remote control.
3. Turn the master conveyor power off.
4. Throttle the tractor down to an idle.
5. Disengage the PTO.
6. Stop the engine and exit the tractor.

## 6.5 TEAR DOWN



Make sure nobody is under the reloader.



To Prevent Serious Injury Or Death



- Keeps hands and body out of the hitch area when attaching towing vehicle.
- Keep body clear of crush point between towing vehicle and load.
- Keeps hands, legs and feet from under tongue and hitch until jack is locked into place.

When the operation has completed, follow the steps listed below:

1. Make sure the reloader has been completely emptied of material.
2. Retract the body lift cylinder to position the reloader into the transport position.
3. Unhook the hydraulic hoses, PTO, and the power cord.
4. Store them in a secure location.
5. Hitch the tractor to the front of the reloader. (See section 6.7.1 Hitching To Tractor.)
6. Reloader is ready for transport.

## 6.6 HYDRAULIC HOOK-UP

The reloader has 4 hydraulic circuits for hookup.

HOSE IDENTIFICATION COLORS & QUANTITIES	
PRESSURE: Red Cable Tie	
RETURN: Blue Cable Tie	
(1) Red / (1) Blue	Stabilizer
(2) Red / (2) Blue	Hitch
(3) Red / (3) Blue	Side Panels
(4) Red / (4) Blue	Lift

**Tractor PTO Horsepower Requirements:** The hydraulic horsepower requirements may not reflect adequate tractor size for towing the machine. Refer to tractor weight requirements for these recommendations and safety section for additional tractor and towing requirements.

Call the factory for further information.

## 6.7 TRANSPORTING

### CAUTION

#### AVOID SERIOUS INJURY OR DEATH

- Read and understand owner's manual before using. Review safety precautions annually.
- Before operating the reloader, look in all directions and make sure no bystanders, especially small children are in the work area.
- No riders allowed when transporting.
- Do not drink and drive.
- Before moving, be sure required lights and reflectors are installed and working.
- Before maintenance or repair, turn the master power off, and disconnect the PTO.
- Place safety stands under frame and chock wheels before working on tires or chassis.
- Maintain wheel bolts at torque as recommended in the manual.
- If equipped with brakes, maintain proper adjustment.
- Reloader should be completely emptied and the body lowered, with hoses and electrical secured prior to transporting.

### CAUTION

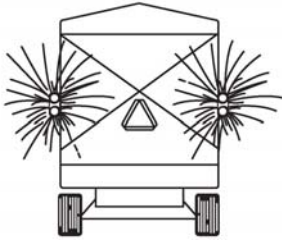

#### Pull-Type Units

- Use flashing warning lights when transporting on ALL highways (public roadways) at ALL times (Tractor towed models) EXCEPT WHEN PROHIBITED BY LAW! (Check w/local law enforcement).
- By all state and federal laws, implement lights do not replace the SMV (Slow-Moving Vehicle) identification emblem. All towed agricultural vehicles must display SMV emblems when traveling LESS than 20 mph (32 kph).
- Check for traffic constantly. Be sure you can see that no one is attempting to pass you and that all traffic is sufficiently clear from you before making any turns.
- Securely attach to towing unit. Use a high strength appropriately sized hitch pin with mechanical retainer and attach safety chain.
- Do not exceed 20 mph (32 kph). Slow down for corners and rough terrain.

### WARNING



#### To Prevent Serious Injury Or Death

- Keeps hands and body out of the hitch area when attaching towing vehicle.
- Keep body clear of crush point between towing vehicle and load.
- Keeps hands, legs and feet from under tongue and hitch until jack is locked into place.

## **WARNING**



### To Prevent Serious Injury Or Death

- Shift to lower gear before going down steep grades.
- Avoid traveling on slopes or hills that are unsafe.
- Keep towing vehicle in gear at all times.
- Never exceed a safe travel speed (which may be less than 20 MPH.).

## **WARNING**

You must observe all applicable traffic laws when transporting on public roadways. Check local laws for all highway lighting and marking requirements. Failure to heed may result in serious personal injury or death.

## **WARNING**

(Tractor Powered) Do not tow at speeds in excess of 20 mph. Failure to heed may result in serious personal injury or death.

## **IMPORTANT**

If you will travel on public roads and it is legal to do so, you must know all rules governing such operation. This will include lighting and brake requirements in addition to traffic rules.

### 6.7.1 Hitching To Tractor

## **WARNING**



- Do not allow anyone to stand between the tongue or hitch and the tractor when backing up to the Reloader.
- Keeps hands and body out of the hitch area when attaching towing vehicle.
- Keep body clear of crush point between towing vehicle and load.

1. Move to the operator's position, start the engine and release the parking brake.
2. Move the tractor in front of the reloader.
3. Connect the light cord along with the hydraulics for the hitch and outriggers.
4. With the hydraulics hooked up, extend the outrigger cylinders to lift the hitch to the proper tractor drawbar height.
5. Extend the hitch to the fully out position and install the locking pin and retainer clip.
6. Slowly move the tractor backwards towards the reloader and align the drawbar with the implement's hitch.
7. Fasten the reloader hitch to the tractor drawbar with a properly sized hitch pin with safety retainer. (Reference ANSI/ASABE AD6489-3 Agricultural vehicles - Mechanical connections between towed and towing vehicles - Part 3: Tractor drawbar.).
8. If jack stand was used, move the jack stand to transport position.
9. Fully retract the outrigger cylinders into the transport position.
10. Make sure lights are functioning properly.

### 6.7.2 Safety Chain



A safety chain must be installed to retain the connection between the tractor (or other towing vehicle) and implement whenever traveling on public roads in case the hitch connection would separate.

The chain must be of adequate size to hold the weight of the loaded reloader. See your ag cart or wagon owner / operator's and parts book, which is also available at [www.meyermfg.com](http://www.meyermfg.com).

**NOTE: If using a grab hook at the end(s) of the chain to secure the chain to itself, a hook latch (Item 1) must be installed.**

The length of the safety chain is not to be any longer than necessary to turn without interference. If any chain links or attachment hardware are broken or stretched, repair before using. Store chain so it does not corrode or become damaged. Do not use this chain for other implements because the strength and length of the chain may not be adequate. Identify this chain for use on this particular reloader.

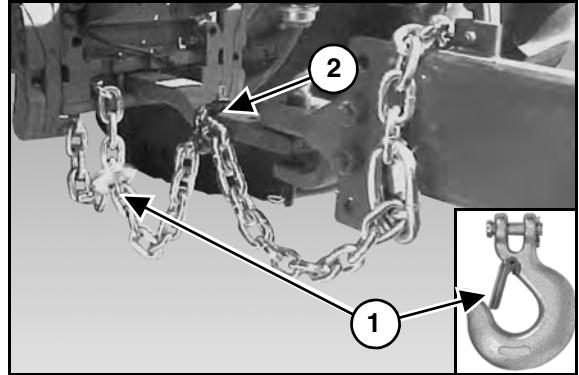

**NOTE: Do not use the intermediate support (Item 2) as the attaching point.**



If you do not have a safety chain, or a replacement safety chain is needed, see your local Meyer dealer and do not operate on public roads until you are able to travel with the safety chain properly installed.

### 6.7.3 Tractor Towing Size Requirements

The minimum tractor weight when towing without implement brakes is listed below. The minimum tractor weight, up to 20 mph (33 kph) needs to be 2/3's of the box Gross Weight (GW).

MODEL	GROSS WEIGHT (GW) (LBS)		2/3		MINIMUM TRACTOR WEIGHT (LBS)
RL30-30	23,000	x	0.667	=	15,341

#### 6.7.4 Unhooking The Tractor

1. Park the implement on level ground. Put the tractor controls in neutral, set the parking brake.
2. Place wheel chocks in front and in back of the implement wheels on opposite sides to prevent the implement from rolling after the tractor is unhooked.
3. Lower the outriggers until they lift the hitch off the drawbar of the tractor.
4. Remove the hitch pin.
5. Unhook safety chain from tractor drawbar and intermediate support. (Remove the pin for retracting the hitch if desired.)
6. Slowly move the tractor away from the hitch and set parking brake. (Retract the hitch if desired.)
7. Install manual jack if desired.
8. Raise the outriggers to lower the trailer if the manual jack is not installed.
9. Disconnect the power cord and put into storage holder.
10. Disconnect the hydraulic hoses from the tractor hydraulic ports and secure them in the storage compartments to keep the hose couplers clean.

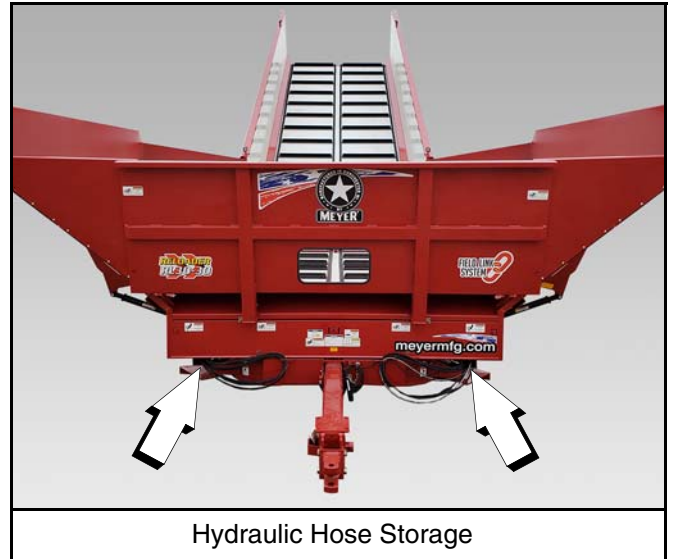

**NOTE: A manual jack has been provided when storing this equipment in the hitching position.**



**Meyer Manufacturing Corporation**

674 W. Business Cty Rd A

Dorchester, WI 54425

Phone: 1-800-325-9103

Fax: 715-654-5513

Email: [parts@meyermfg.com](mailto:parts@meyermfg.com)

Website: [www.meyermfg.com](http://www.meyermfg.com)

**FARM EQUIPMENT BUYERS TRUST THE NAME MEYER!**



## 7.0 OPERATION

---

### CAUTION

DO NOT allow anyone to operate, service, inspect or otherwise handle this reloader until all operators have read and understand all of the instructional materials in this Operator's Manual and have been properly trained in its intended usage.

Before operating the reloader, look in all directions and make sure no bystanders, especially small children are in the work area.

Do not climb or step on any part of the reloader at any time.

Do not overload the machine.



---

### 7.1 LOADING

### WARNING

Hydraulic fluid escaping under pressure can have sufficient force to cause injury. Keep all hoses and connections in good serviceable condition. Failure to heed may result in serious personal injury or death.

### CAUTION

Shutoff and lockout power before performing machine service, adjusting, maintaining, or clearing an obstruction from this machine. Refer to section 5.3 SHUTOFF & LOCKOUT POWER.

Once the reloader has been set up, follow the steps listed below:

1. Follow the Start Up procedure 6.4.2.
2. Pull the loading vehicle under the discharge area of the reloader in order for it to be loaded.
3. Back your unloading vehicle into the reloader.
4. Unload the material into the reloader.
5. Once all material has been discharged into the reloader, pull the trailer away.

**NOTE: When the reloader conveyor stops, the vehicle unloading into the reloader should stop as well.**

## 7.2 UNLOADING



Shutoff and lockout power before performing machine service, adjusting, maintaining, or cleaning an obstruction from this machine. Refer to section 5.3 SHUTOFF & LOCKOUT POWER.



Keep all persons clear from under reloader and the unloading area.



**IMPORTANT**

The reloading process described is to be performed by the operator alone. This will eliminate unexpected “start-ups” and minimize other hazards that could result by more than one person in control.

**NOTE:** Unloading is best observed from the operator’s seat.

Once the trailer under the discharge end of the reloader is full, follow the steps listed below:

1. Stop the conveyor.
2. Drive the loaded trailer away.
3. Drive the next empty trailer into place.
4. Start the conveyor.

Repeat this process as needed.

**NOTE:** When the reloader conveyor stops, the vehicle unloading into the reloader should stop as well.



Never enter the reloader without shutting power “OFF” and locking out the machine. (See 5.3 SHUTOFF & LOCKOUT POWER).

Never use “LIVE” power to aid in the clean-out of a clogged machine.

**IMPORTANT**

If any component fails, shut off and lockout all power to the reloader. Repair or replace damaged components before proceeding with unloading of the material.

## 8.0 MAINTENANCE

### 8.1 LUBRICATION



**CAUTION**

Shutoff and lockout power before performing machine service, adjusting, maintaining, or clearing an obstruction from this machine. Refer to section 5.3 SHUTOFF & LOCKOUT POWER.

**IMPORTANT**

Fluid such as hydraulic fluid, grease, etc. must be disposed of in an environmentally safe manner. Some regulations require that certain spills and leaks on the ground must be cleaned in a specific manner. See local, state and federal regulations for the correct disposal.

**NOTE:** Use a grease type that is composed of a high quality lithium complex or better, unless otherwise stated. We recommend using a #1 grade in colder temperatures or a #2 grade in warmer temperatures.

#### 8.1.1 Daily Lubrication (every 8-10 hours of operation)

- Grease the PTO driveline universal joints (Item 1) with about 5 pumps of grease every 8 hours.
- Grease the PTO driveline plastic guard (Item 2) with about 5 pumps of grease every 8 hours.
- Grease telescoping members (Item 3) with about 8-10 pump of grease every 8 hours (zerk accessible through the plastic guards). Take apart occasionally to make sure adequate lubrication is being added.
- Grease the six main apron bearings (Item 4). Over-greasing is not possible.
- Apply oil to the apron chains and roller chains.

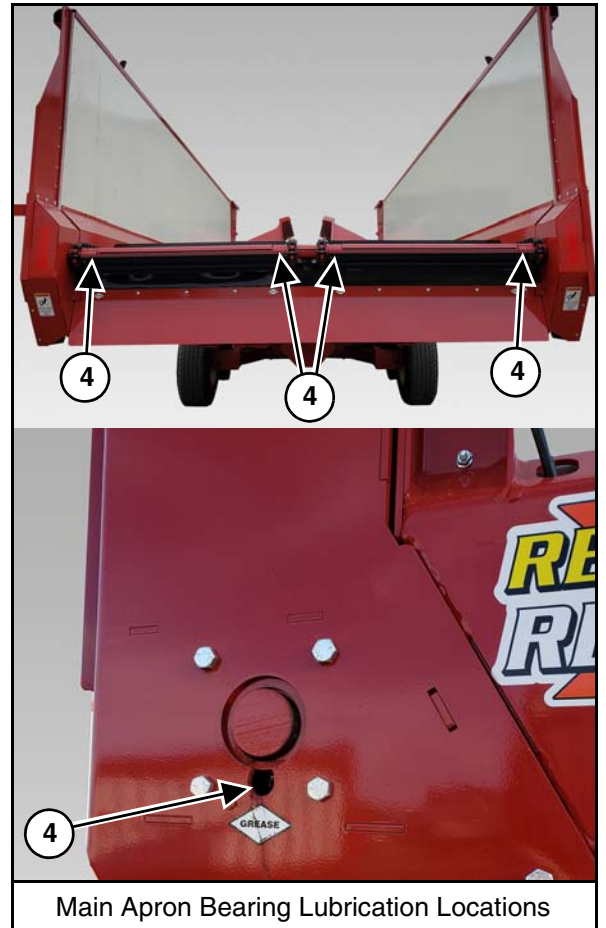
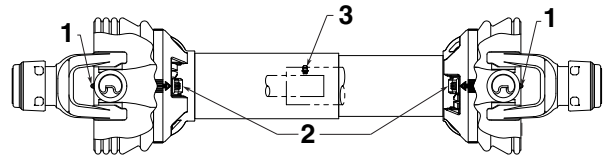

- Grease the four inner sprockets (Item 5).

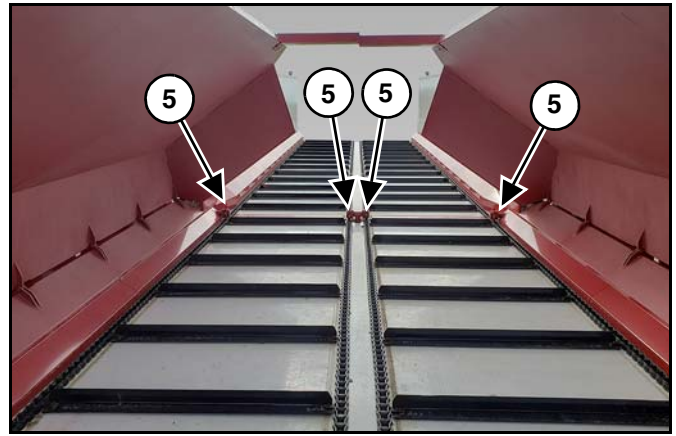

### 8.1.2 Weekly Lubrication (every 56-70 hours of operation)

- Grease the hubs (Item 6) (both sides).
- Grease the tandem wings (Item 7) (both sides).

**NOTE: Jack up empty trailer off ground and support on adequate jack stands to relieve pressure and grease until it purges.**

- Check both gearboxes for any leaks. If leaking, replace required input/output shaft seals.

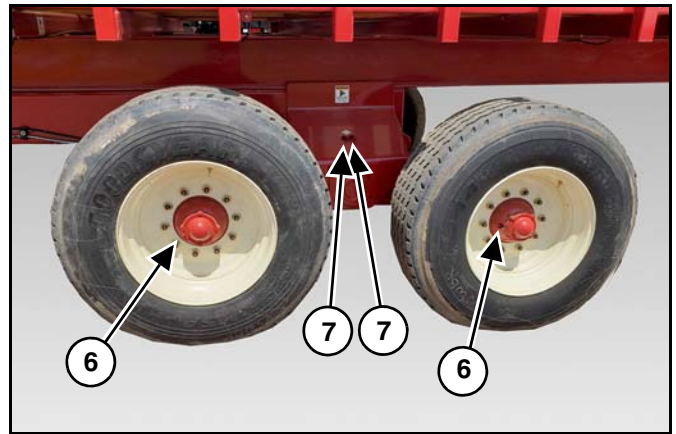

### 8.1.3 Monthly Lubrication (every 224-280 hours of operation)

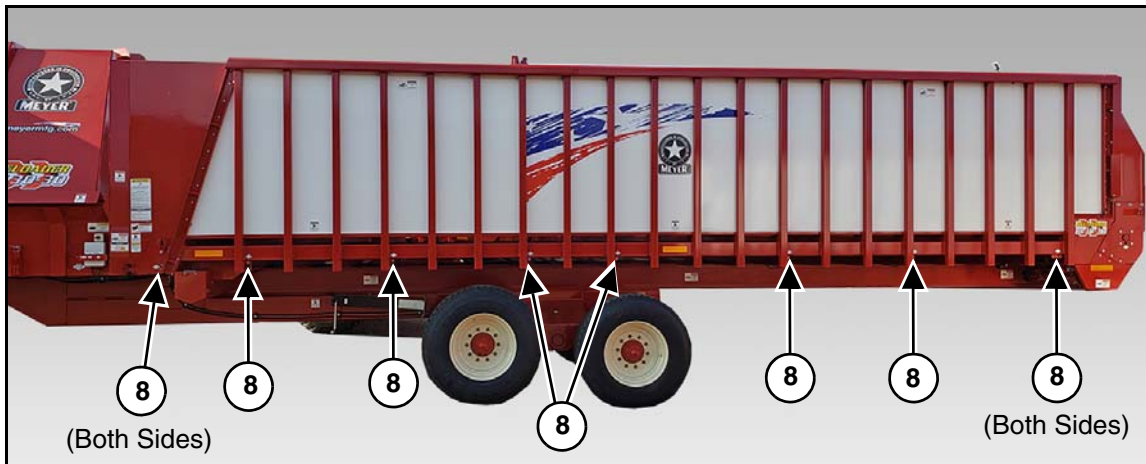

- Grease (15) driveline bearings (Item 8) with one pump of grease.

- Change oil in both gearboxes after the first month of operation. (See section 8.1.5 Gearbox Oil Change.)
- With the reloader in the transport position, check both gearbox oil levels by removing the hex head plugs (Item 9). Lubricate with EP 80W90.

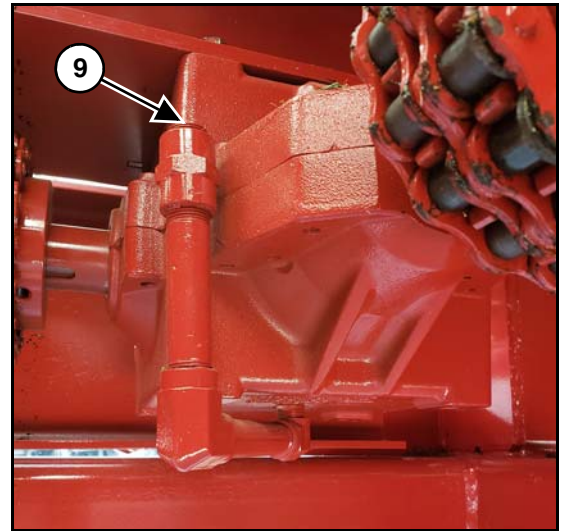

Front Gearbox

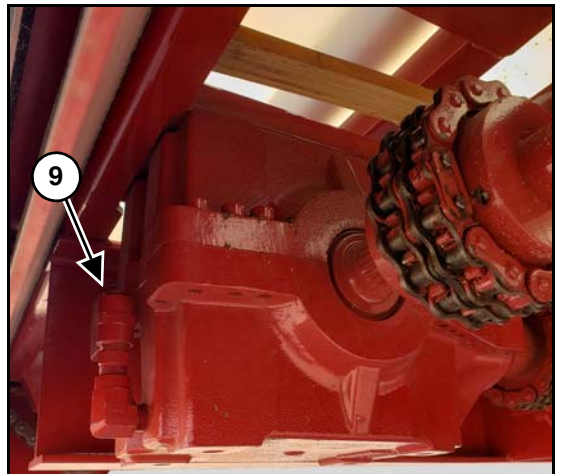

Rear Gearbox

- Lubricate (6) chain couplers (Item 10) with new 30 weight oil.

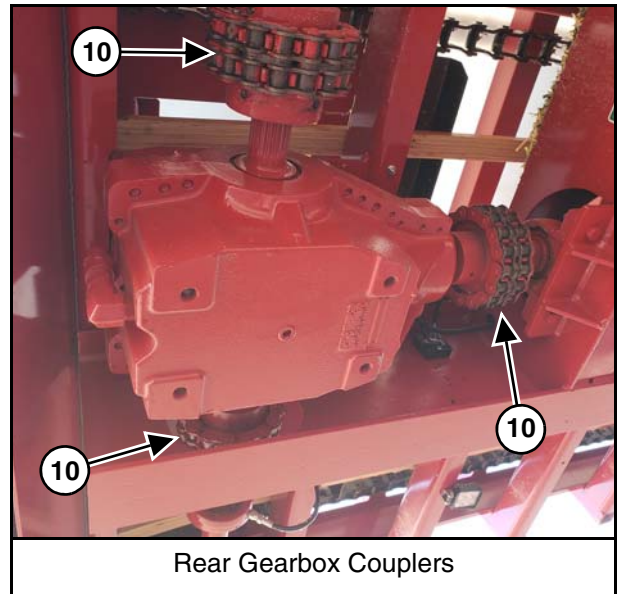
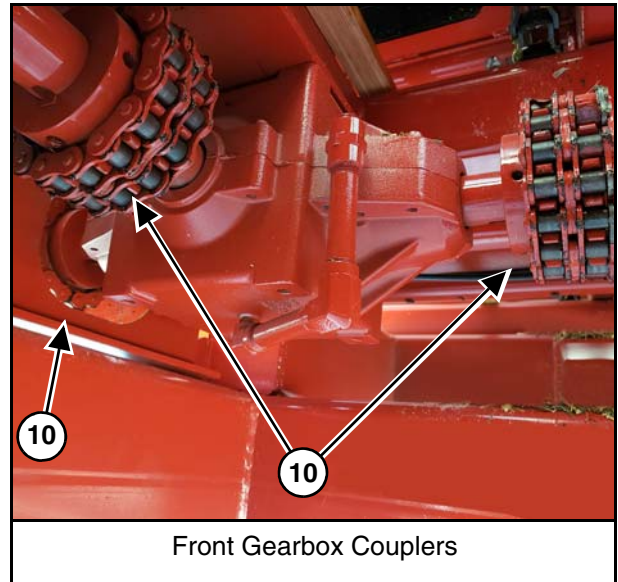

#### 8.1.4 Annual Lubrication

- Change oil in both gearboxes. (See section 8.1.5 Gearbox Oil Change.)
- Take apart the PTO each season to be cleaned with solvent and re-coated with grease before re-assembling.

## 8.1.5 Gearbox Oil Change

### Front Gearbox:

- Drain the oil by removing the fill tube (Item 1).
- Reinstall the fill tube.
- Remove the allen head plug from the fill tube (Item 2).
- Fill with 80W90 to the top of the fill tube.

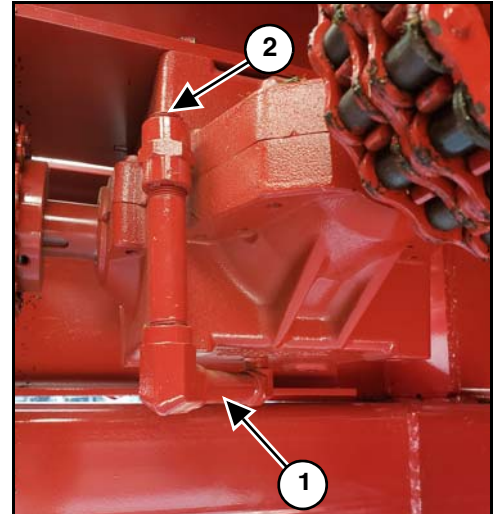

### Rear Gearbox:

- Drain the oil by removing the bottom plug (Item 3).
- Reinstall the plug.
- Remove the allen head plug from the fill tube (Item 4).
- Fill with 80W90 to the top of the fill tube.

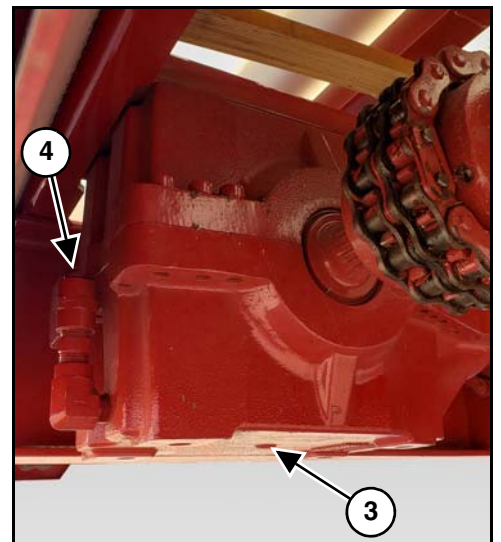

## 8.2 ADJUSTMENTS



Shutoff and lockout power before performing machine service, adjusting, maintaining, or clearing an obstruction from this machine. Refer to section 5.3 SHUTOFF & LOCKOUT POWER.

### 8.2.1 Adjust Apron Chain Tension (Daily Every 8-10 Hours)

Visually inspect the tension on the apron chains.

Initial break-in of the chain will require visual inspection every hour for the first 100 hours of service.

The second apron chain slat (approximately three feet back from the front of the box) should be 1/8" to 1/4" off the return slides (both sides).

Alternatively, torque each tightener bolt to 30 ft/lbs.

Tighten the adjuster bolts (Item 1) at each end of the front sprocket shaft equally.

**NOTE: If adjuster bolt(s) reaches maximum travel, remove equal links from each strand. Removable links are provided in the chain.**

### 8.2.2 Adjust Wheel Bearing Preload

1. Chock all four wheels or hitch to tractor with engine off, key removed and parking brake set. Jack empty trailer off ground and support with adequate jack stands.
2. Push back and forth on each wheel assembly. If play is detected, bearings need adjusting.
3. If adjusting bearings, it is suggested the bearings be repacked as described previously.
4. Remove hub cap and remove cotter pin from spindle nut.
5. Tighten spindle nut to remove all play. It should be snug and slight drag can be felt while rotating the wheel.
6. If the cotter pin hole in the spindle does not line up with the notch in spindle nut, back off the spindle nut only enough to line up. Reinstall cotter pin. If cotter pin is damaged, replace it.
7. Replace hub cap and lower wheel to the ground.

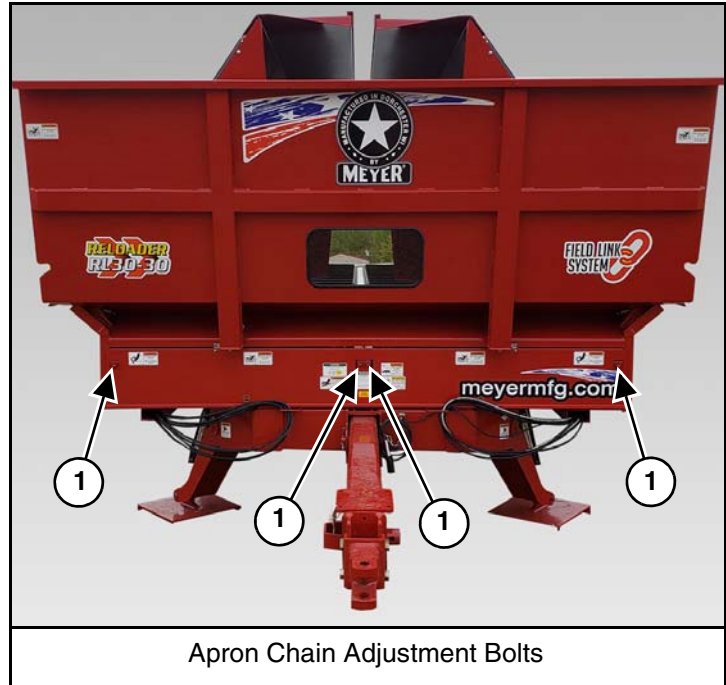



### 8.2.3 Wheels and Tires

BOLT/STUD SIZE	SOCKET SIZE	PRESS FORMED WHEEL CENTER	BOLT TYPE	HEAVY DUTY WHEEL CENTER
5/8	15/16 / 1-1/16	100 ft lbs	Bevel or Flange Nut	160 ft-lb
3/4	1-1/8 / 1-1/2	N/A	Flange Nut	378 ft-lb

#### Reloader Tire Wheel Installation

- Clean adjoining surfaces.
- Start nuts to bring wheel flush to hub mounting surface.
- Avoid wheel binding on hub.
- Install remaining wheel nuts. Torque to 50 ft-lbs. Then re-torque to required full torque.
- Re-torque wheel nuts after 50-100 miles.



**THESE INSTRUCTIONS ARE NOT COMPLETE. READ AND FOLLOW ALL PROCEDURES IN USER'S GUIDE TO WHEELS AND RIMS BY "THE MAINTENANCE COUNCIL" #T0410.**

#### Tire Inflation

TIRE SIZE	PSI
386/65/22.5	100

### 8.3 STORING THE RELOADER

LOCKOUT / TAGOUT the machine / reloader. (See 5.3 SHUTOFF & LOCKOUT POWER).

**NOTE: A manual jack has been provided when storing this equipment in the hitching position.**

Sometimes it may be necessary to store your Meyer Reloader for an extended period of time. Below is a list of items to perform before storage.

- Empty all the material from the reloader. (See 7.0 OPERATION on page 33.)
- Thoroughly clean the equipment.
- Lubricate the equipment. (See 8.1 LUBRICATION on page 35.)
- Apply oil to the apron chains and inspect all reloader components for wear or damage. Repair and replace components as necessary.
- Make appropriate adjustments to equipment. (See 8.2 ADJUSTMENTS on page 40.)
- Place hydraulic hoses and 7-pin connector in the storage brackets (if equipped).
- Inspect the hitch and all welds on the equipment for wear and damage.
- Check for loose hardware, missing guards, or damaged parts.
- Check for damaged or missing safety signs (decals). Replace if necessary.
- Replace worn or damaged parts.
- Touch up all paint nicks and scratches to prevent rusting.
- Place the equipment in a dry protected shelter.
- Place the equipment flat on the ground.

### 8.4 RETURNING THE RELOADER TO SERVICE

After the Meyer Reloader has been in storage, it is necessary to follow a list of items to return the equipment to service.

- Be sure all shields and guards are in place.
- Lubricate the equipment.
- Connect to a tractor and follow Pre-Operation and Operational Checks.
- Check for leaks. Repair as needed.

## 9.0 PARTS REPAIR AND REPLACEMENT

### 9.1 REPLACEMENT PARTS



Before servicing this equipment, ensure that all personnel, including family members are familiar with the equipment and the safety hazards that are present, along with the safety practices that should be observed while working in this equipment.



Inspect the axles, o-beams, spindles, tires, hitches and all safety shielding, safety signs and safety lighting regularly. These parts if not watched closely, could pose potential injury or death. If any part is found in need of repair, follow the SHUTOFF & LOCKOUT POWER recommendations and have qualified personnel repair immediately.

Shutoff and lockout power before performing machine service, adjusting, maintaining, or clearing an obstruction from this machine. Refer to section 5.3 SHUTOFF & LOCKOUT POWER.

## IMPORTANT

It is important that everyone who works on this equipment is properly trained to help ensure that they are familiar with this procedure and that they follow the steps outlined above. This manual will remind you when to Shutoff & Lockout Power.

At times, parts on this implement will become worn or damaged. Performing repairs on this implement can pose a risk of injury including death. To reduce risk, the party that will be doing the repair should be very knowledgeable of the implement and the equipment that they will be using to do the repair.

- Review the repair so that a plan can be put together and the proper equipment can be used to repair this implement safely and correctly.
- Personal safety equipment may include items such as safety glasses, protective footwear, hearing protection, gloves, fire retardant clothes, etc.



### Crushing Hazard

Do Not work under suspended or blocked parts.



- The use of hoists and/or supports may be needed to handle heavy components.
- If the implement is being repaired in the field, make sure the parking brake of the tractor is engaged, the implement is on solid and level ground.
- Welding and torching should be done by properly trained individuals who have proven their skills.

## IMPORTANT

Call the factory for any additional details you may need to perform the repair. Some parts may come with instruction sheets to assist in the repair. Instruction sheets may be provided with your parts order. Otherwise, if available, instruction sheets can be e-mailed or faxed for you convenience. Call Meyer Manufacturing Corporation toll free at 1-800-325-9103 or email [parts@meyermfg.com](mailto:parts@meyermfg.com).

**NOTE:** Be environmentally friendly and dispose of any waste materials properly. Recycle when appropriate.



# 10.0 SPECIFICATIONS

DIMENSIONS	RL30-30
Inside Length	
Inside Width	
Inside Height	
Overall Length	
Overall Width	
Overall Height	
Overall Side Height	
Stringer Width	

SPECIFICATIONS	RL30-30
Apron Chains (pintle)	
Rear Drive Shaft (HD Solid Shaft)	
Power Source	
Upright Spacing	
Upright / Cross Member Construction	
Unloading Time (Dependent of Hyd. System)	







**Meyer Manufacturing Corporation**

674 W. Business Cty Rd A

Dorchester, WI 54425

Phone: 1-800-325-9103

Fax: 715-654-5513

Email: [parts@meyermfg.com](mailto:parts@meyermfg.com)

Website: [www.meyermfg.com](http://www.meyermfg.com)