

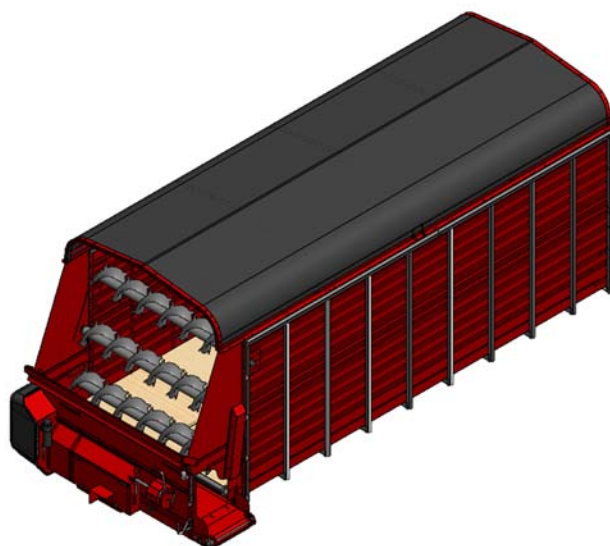

Patent
8,818,882B2



RT / RTX SERIES

RT614 • RT616 • RT618 • RT620 • RT622

RTX620 • RTX622 • RTX624 • RTX626

2015 MODEL YEAR AND LATER

Owner / Operator's Manual



1.0 IMPORTANT INFORMATION

Prior to 2016 model year, the serial number plate is located to the right of the control handles as well as stamped above the discharge opening on the unit discharge end frame.

For 2016 model year and later, the serial number plate is located above the discharge opening on the unit discharge end frame.

Please enter the model, serial number and additional information in the space provided for future reference.

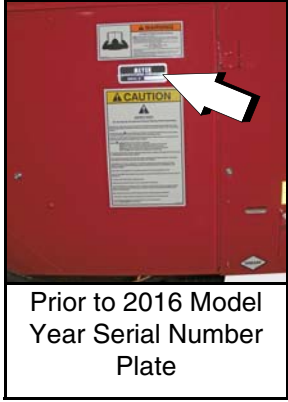

Model No. _____

Serial No. _____

Date of Purchase _____

Dealership _____

Dealership Phone No. _____



Always use your serial number when requesting information or when ordering parts.

HOW TO READ YOUR SERIAL NUMBER



EXAMPLE: 14R6201

Model Year / RT / Model / Sequence Of Build

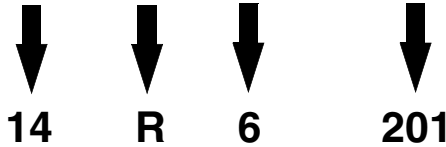

Meyer Manufacturing Corporation
 674 W. Business Cty Rd A
 Dorchester, WI 54425
 Phone: 1-800-325-9103
 Fax: 715-654-5513
 Email: parts@meyermfg.com
 Website: www.meyermfg.com



2.0 PRE-DELIVERY & DELIVERY CHECK LIST

PB-RT-2W Check List

Meyer Manufacturing Corporation

Phone: 715-654-5132 • Toll-Free: 1-800-325-9103 • P.O. Box 405 • Dorchester, WI 54425

This Pre-Delivery & Delivery Check List must be gone through by the Selling Party and the Customer to validate the Owner's Registration Form.

PRE-DELIVERY CHECK LIST

After the New Meyer Forage Box has been completely set-up, check to be certain it is in correct running order before delivering it to the customer.

The following is a list of points to inspect:

Check off each item as you have made the proper adjustments and found the item operating satisfactorily. Any adjustments made, MUST be according to specifications defined in this manual.

- All shields and guards are in place and securely fastened.
- All bolts and other fasteners are secure and tight.
- All mechanisms operate trouble free.
- All grease fittings have been lubricated, gear boxes filled to proper levels, and all roller chains are oiled. See "Lubrication" section of this manual.
- PTO shields turn freely.
- All roller chain springs adjusted properly for automatic tensioning. See "Adjustments" section in this manual.
- Cross Conveyor Belt or Chain and Main Apron Chains are at proper tension. See "Adjustments" section in this manual.
- Emergency Stop and Trip Cables operate properly.
- All decals are in place and legible.
- All stop/tail/turn lights work properly.

DELIVERY CHECK LIST

The following check list is an important reminder of valuable information that **MUST** be passed on to the customer at the time the unit is delivered.

Check off each item as you explain it to the customer.

- Explain to the customer that pre-delivery check list was fully completed.
- Give customer the Owner & Operator's Manual. Instruct to read and completely understand its contents **BEFORE** attempting to operate the Forage Box.
- Explain and review with customer the New Meyer Forage Box manufacturer's warranty.
- Show the customer where to find the serial number on the implement.
- Explain and review with the customer "Safety Precautions" section of this manual.
- Explain and review with customer the "Emergency Stop" and proper "Start-up and Operating Procedures" sections of this manual.
- Demonstrate the "Emergency Stop" operation, activation and reset. Also, demonstrate the PTO shaft locking device, main outfeed clutch adjustments, and the three control lever operations.
- Explain that regular lubrication and proper adjustments are required for continued proper operation and long life of the Forage Box. Review with the customer the "Lubrication" and "Adjustments" sections of this manual.
- Explain the importance of cross conveyor & main apron chain tension, and the need to watch and tighten during the break in period.
- Explain and review with the customer the recommended loading and unloading procedures.
- Fully complete this "PRE-DELIVERY & DELIVERY CHECK LIST" with the customer.



Meyer Manufacturing Corporation

674 W. Business Cty Rd A

Dorchester, WI 54425

Phone: 1-800-325-9103

Fax: 715-654-5513

Email: parts@meyermfg.com

Website: www.meyermfg.com

3.0 INTRODUCTION

Congratulations on your purchase of a new Meyer farm equipment product. Undoubtedly you have given much consideration to your purchase and we're proud that you have selected Meyer. Pride in craftsmanship, engineering and customer service have made Meyer products the finest in the farm equipment industry today.

There is no substitute for quality. That is why thousands of people like you have purchased Meyer farm equipment. They felt it was the best equipment to serve their farming needs, now and in years to come. We ask that you follow our policy of "safety first", and we strongly suggest that you read through the Operator's & Parts manual before operating your Meyer farm equipment. Meyer Manufacturing Corporation wants to thank you for not compromising quality. We are determined to offer excellence in customer service as well as provide you with the very best value for your dollar.

Sincerely,

All Employees of

MEYER MANUFACTURING CORPORATION

The RT Model is available as a truck, Ag cart or wagon mounted unit pulled and powered by a farm tractor.

When the PTO is referred to, it means power takeoff from the tractor.

The RT Model may be referred to as forage box, implement or front unloading forage box in this manual.

NOTE: All references to right hand (RH), left hand (LH) front and rear apply to the product as viewed from the rear of the box.



IMPORTANT: You are urged to study this manual and follow the instructions carefully. Your efforts will be repaid in better operation and service as well as a savings in time and repair expense. Failure to read this manual and understand the machine could lead to serious injury. If you do not understand instructions in this manual, contact either your dealer or Meyer Manufacturing Corp. at Dorchester, WI 54425.



WARRANTY: At the front of this manual is an "Owner's Registration Form". Be sure your dealer has completed this form and promptly forwarded a copy to Meyer Manufacturing to validate the manufacturer's warranty. The product model and serial number are recorded on this form and on the inside of the front cover for proper identification of your Meyer Forage Box by your dealer and the manufacturer when ordering repair parts. The serial number is stamped above the discharge opening on the unit discharge end frame.



REPAIR PARTS: At the back of this manual is the repair parts section. All replacement parts are to be obtained from or ordered through your Meyer dealership. When ordering repair parts, refer to the parts section and give complete information including quantity, correct part number, detailed description and even Model No. and Serial No. of the forage box which needs repair parts.

Manufacturer's Statement: Meyer Manufacturing Corporation reserves the right to make improvements in design, or changes in specifications at any time, without incurring any obligation to owners of units previously sold. This supersedes all previous published instructions.

3.1 RT AND RTX STANDARD FEATURES

Front Unload	RT616	RT618	RT620	RT622
RT Variable Speed System - 0-17'/minute (PTO drive standard)	Std	Std	Std	Std
Apron Chains (heavy duty pintle)	667X	667X	667X	667X
Auger Feathering System & Conveyor Clutch/Safety Clutch	Std	Std	Std	Std
Cross Conveyor Chain Hold-Downs	Std	Std	Std	Std
Fold-Down Conveyor Extension with Lift Assist	Std	Std	Std	Std

Front Unload	RTX620	RTX622	RTX624	RTX626
RT Variable Speed System - 0-17'/minute (PTO drive standard)	Std	Std	Std	Std
Apron Chains (heavy duty pintle)	667X	667X	667X	667X
Auger Feathering System & Conveyor Clutch/Safety Clutch	Std	Std	Std	Std
Cross Conveyor Chain Hold-Downs	Std	Std	Std	Std
Fold-Down Conveyor Extension with Lift Assist	Std	Std	Std	Std
Superslide, Solid Poly Floor (no plywood) (RTX600)	Std	Std	Std	Std
12" Higher Sides with 4th Beater System	Std	Std	Std	Std

3.2 RT AND RTX OPTIONS

Front Unload	RT616	RT618	RT620	RT622
Hydraulic Front Drive System (in lieu of PTO)	Opt	Opt	Opt	Opt
Hydraulic In-Cab Controls (in lieu of PTO) - includes hyd lift conveyor	Opt	Opt	Opt	Opt
36" Fold-Down Cross Conveyor Extension (in lieu of standard 24")	Opt	Opt	Opt	Opt
Hydraulic Lift Option for Fold-Down Cross Conveyor Extension	Opt	Opt	Opt	Opt
Roof Assembly (removable)	Std	Std	Std	Std
6" Higher Roof Assembly (removable) - or 12" higher sides	Opt 616	Opt 618	Opt 620	Opt 622
Roof Hood Assembly (right hand, open top units only)	Opt	Opt	Opt	Opt
Truck Mount/Trailer Mount/Wagon Mount	Opt	Opt	Opt	Opt
Tarp Systems (with front enclosures)	-	-	-	-
Front to Back Scissor Tarp (electric)	Opt	Opt	Opt	Opt
Side to Side Roll Tarp (electric)	Opt	Opt	Opt	Opt
Clad Tuff Fiberglass Sides & Back	Opt	Opt	Opt	Opt
Superslide, Solid Poly Floor (no plywood) (RT600)	Opt 616	Opt 618	Opt 620	Opt 622

Front Unload	RTX620	RTX622	RTX624	RTX626
Hydraulic Front Drive System (in lieu of PTO)	Opt	Opt	Opt	Opt
Hydraulic In-Cab Controls (in lieu of PTO) - includes hyd lift conveyor	Opt	Opt	Opt	Opt
36" Fold-Down Cross Conveyor Extension (in lieu of standard 24")	Opt	Opt	Opt	Opt
Hydraulic Lift Option for Fold-Down Cross Conveyor Extension	Opt	Opt	Opt	Opt
Roof Assembly (removable)	Opt	Opt	Opt	Opt
Roof Hood Assembly (right hand, open top units only)	Opt	Opt	Opt	Opt
False Front Gate for Grain Kit	Opt	Opt	Opt	Opt
Truck Mount/Trailer Mount/Wagon Mount	Opt	Opt	Opt	Opt
Tarp Systems (with front enclosures)	-	-	-	-
Front to Back Scissor Tarp (electric)	Opt	Opt	Opt	Opt
Side to Side Roll Tarp (electric)	Opt	Opt	Opt	Opt
Clad Tuff Fiberglass Sides & Back	Opt	Opt	Opt	Opt



Meyer Manufacturing Corporation

674 W. Business Cty Rd A

Dorchester, WI 54425

Phone: 1-800-325-9103

Fax: 715-654-5513

Email: parts@meyermfg.com

Website: www.meyermfg.com

TABLE OF CONTENTS

1.0	IMPORTANT INFORMATION	2
2.0	PRE-DELIVERY & DELIVERY CHECK LIST	3
3.0	INTRODUCTION	5
3.1	RT AND RTX STANDARD FEATURES	6
3.2	RT AND RTX OPTIONS	7
4.0	MANUFACTURER'S WARRANTY	11
5.0	SAFETY	13
5.1	SAFETY PRECAUTIONS	14
5.2	SAFETY SIGNS	16
5.3	EMERGENCY SAFETY STOP	21
5.3.1	Emergency Stop Trip Locations	21
5.3.2	Front Unload Emergency Stop Operation	21
5.3.3	Resetting the Emergency Stop	21
5.4	SHUTOFF & LOCKOUT POWER	22
5.4.1	Shutoff & Lockout Power Recommendations	22
6.0	PRE-OPERATION	23
6.1	PRODUCT INSPECTION	23
6.2	LIGHT HOOK-UP	24
6.3	PTO HOOK-UP	24
6.4	HYDRAULIC HOOK-UP	25
6.5	HITCHING TO TRACTOR	25
6.6	START-UP AND SHUT-DOWN	26
6.6.1	Start-Up	26
6.6.2	Shut-Down	26
6.7	OPERATIONAL CHECKS	27
6.8	TRANSPORTING	28
6.8.1	Fold Down Cross Conveyor Extension	29
6.9.1	Safety Chain	30
6.9.2	Brake Information	30
6.9.3	Tractor Towing Size Requirements	31
7.0	OPERATION	33
7.1	LOADING	33
7.2	NO ROOF IMPLEMENTS	34
7.3	UNLOADING	34

7.5 UNHOOKING THE TRACTOR	36
8.0 MAINTENANCE	37
8.1 LUBRICATION	37
8.2 ADJUSTMENTS	41
8.2.1 Front Cross Conveyor every 100-150 Loads	41
8.2.2 Main Apron Chains	42
8.3 CLEAN-OUT PANEL	43
8.4 INDEPENDENT OUTFEED CLUTCH	44
8.4.1 Independent Outfeed Clutch Belt Replacement	44
8.4.2 Independent Outfeed Clutch Adjustment	44
8.5 VARIABLE SPEED CONTROL	45
8.5.1 Variable Speed Belt Replacement	45
8.5.2 Variable Speed Control Adjustment	45
8.6 AUGER CLUTCH	46
8.6.1 Auger Clutch Adjustment	46
8.7 STORING THE FORAGE BOX	47
8.8 RETURNING THE FORAGE BOX TO SERVICE	47
8.9 REPLACEMENT PARTS	48
8.9.1 Shutoff & Lockout Power Recommendations	48
9.0 SPECIFICATIONS	51
9.1 RT SPECIFICATIONS	51
9.2 RTX SPECIFICATIONS	52
MAINTENANCE RECORD	55

4.0 MANUFACTURER'S WARRANTY

2/2015

MEYER RT FORAGE BOX

- I. The "Owner's Registration Form" must be completed in full and promptly returned to Meyer Mfg. Corp. for this warranty to become both valid and effective. All warranties on new Meyer forage boxes shall apply only to the original retail customer from an authorized Meyer Mfg. Corp. dealership.
- II. This warranty shall not apply to any Meyer forage box which has been subjected to misuse, negligence, alteration, accident, incorrect operating procedures, has been used for an application not designed for or pre-authorized by Meyer in writing, has had the serial numbers altered, or which shall have been repaired with parts other than those obtained through Meyer Mfg. Corp. Meyer is not responsible for the following: Depreciation or damage caused by normal wear, lack of reasonable and proper maintenance, failure to follow the operator's manual recommendations or normal maintenance parts and service. Meyer is not responsible for rental of replacement equipment during warranty repairs, damage to a power unit (including but not limited to a truck or tractor), loss of earnings due to equipment down time, or damage to equipment while in transit to or from the factory or dealer.
- III. Meyer Mfg. Corp. warrants new Meyer forage box to be free from defects in material and workmanship under recommended use and maintenance service, as stated in the "Owner / Operator's Manual & Parts Book", as follows:
 - A. Meyer Mfg. Corp. will repair or replace F.O.B. Dorchester, WI, as Meyer Mfg. Corp. elects, any part of a new Meyer Forage Box which is defective in material or workmanship:
 - i. Without charge for either parts or labor during the first (1) year from purchase date to the original retail customer.
 - ii. Without charge for parts only during the second (2) year from purchase date to the original retail customer.
- IV. COMMERCIAL USE: Coverage as in paragraph III.A.i. ONLY, except warranty coverage is for (90) days for parts and labor to the original commercial retail customer.
- V. Repairs eligible for labor warranty must be made by Meyer Mfg. Corp. or an authorized Meyer dealership. The original retail customer is responsible for the transportation of the forage box to the dealership for warranty service or for any service call expenses.
- VI. Except as stated above, Meyer Mfg. Corp. shall not be liable for injuries or damages of any kind or nature, direct, consequential, or contingent, to persons or property. This warranty does not extend to loss of crop or for any other reasons.
- VII. No person is authorized to give any warranties or to assume any other obligation on Meyer Mfg. Corp.'s behalf unless made or assumed in writing by Meyer Mfg. Corp. This warranty is the sole and exclusive warranty which is applicable in connection with the manufacture and sale of this product and Meyer Mfg. Corp's responsibility is limited accordingly.
- VIII. Tires, optional scales and tarps fall under the original manufacturer's warranty.



5.0 SAFETY

The Meyer Forage Box is manufactured with operator safety in mind. Located on the forage box are various safety signs to aid in operation and warn of hazardous areas. Pay close attention to all safety signs on the forage box.

Carefully follow the operating and maintenance instructions in this manual and all applicable safety laws. Failure to follow all safety procedures may result in serious injury or death.

Before attempting to operate this forage box, read and study the following safety information. In addition, make sure that every individual who operates or works with the forage box, whether family member or employee, is familiar with these safety precautions.

Meyer Mfg. Corp. provides guards for exposed moving parts for the operator's protection; however, some areas cannot be guarded or shielded in order to assure proper operation. The operator's manual and safety signs on the forage box itself warn you of hazards and must be read and observed closely!

Safety Alert Symbol

This symbol is used to call attention to instructions concerning personal safety. Be sure to observe and follow these instructions. Take time to be careful!



The signal word **DANGER** on the machine and in the manual identifies a hazardous situation which, if not avoided, WILL result in death or serious injury.



The signal word **WARNING** on the machine and in the manual indicates a potentially hazardous situation which, if not avoided, COULD result in death or serious injury.



The signal word **CAUTION** on the machine and in the manual indicates a potentially hazardous situation which, if not avoided, MAY result in minor or moderate injury. It may also be used to alert against unsafe practices.



IMPORTANT

This notice identifies procedures which must be followed to avoid damage to the machine.

Danger, Warning, Caution, and instructional decals and plates are placed on the equipment to protect anyone working on or around this machine, as well as the components of the machine. All personnel operating or maintaining this equipment must familiarize themselves with all Danger, Warning, Caution, and instructional decals and plates.

5.1 SAFETY PRECAUTIONS



All individuals who will operate this Forage Box must read and completely understand this Operator's And Parts Manual. Operator must have instructions before operating the machine. Untrained operators can cause injury or death.

- Trip the emergency stop regularly with the trip cables to ensure that it will shut the front unloading unit down in an emergency.
- DO NOT allow anyone to operate, service, inspect or otherwise handle this forage box until all operators have read and understood all of the instructional materials in this Operator's And Parts Manual and have been properly trained in its intended usage.
- For an operator to be qualified, he or she must not use drugs or alcohol which impair alertness or coordination while working. An operator who is taking prescription drugs must get medical advice to determine if he or she can safely operate a machine and the equipment.
- Make sure all personnel can READ and UNDERSTAND all safety signs.
- DO NOT allow minors (children) or inexperienced persons to operate this forage box.
- DO NOT operate until all shields and guards are in place and securely fastened.
- DO NOT adjust, clean, lubricate, or reset the emergency stop while the forage box is in motion.
- Inspect when first delivered and regularly thereafter; that all connections and bolts are tight and secure before operating.
- Know how to stop operation of the forage box before starting it!
- Make certain everyone is clear of the forage box before applying power.
- Make certain everyone stays clear of the cross conveyor while operating.
- Keep hands, feet and clothing away from moving parts. Loose or floppy clothing should not be worn by the operator.
- Observe all applicable traffic laws when transporting on public roadways (where legal to do so). Check local laws for all highway lighting and marking requirements.
- Shut off and lock out power before adjusting, servicing, maintaining or clearing an obstruction from this machine. (See 5.4 SHUTOFF & LOCKOUT POWER on page 22.)
- Always enter curves or drive up or down hills at a low speed and at a gradual steering angle.
- Never allow riders on either tractor / truck or equipment.
- Keep tractor / truck in a lower gear at all times when traveling down steep grades.
- Maintain proper brake settings at all times (if equipped).
- DO NOT step up on any part of the forage box at any time. DO NOT use the PTO guard as a step.
- DO NOT step over the power take-off shaft. Stay clear of the PTO at all times.
- Keep PTO shaft telescoping tube shields turning freely. Keep PTO master shield on tractor. Replace damaged or missing shields.
- Match the right tractor PTO spline and speed with the PTO driveline provided with the implement. Never operate PTO above normal 540 RPM rating. Never connect forage box PTO shaft to a 1000 RPM tractor PTO. Never use a spline adapter.
- Stay away from overhead power lines. Electrocution can occur without direct contact.
- Use only properly rated undercarriage and tires.

Safety Precautions For Tractor Towed Units:

- Do not exceed 20 mph (32 kph). Reduce speed on rough roads and surfaces.
- Always install a SMV emblem on pull-type equipment when transporting on roadways and keep clean and bright.
- Always yield to oncoming traffic in all situations and move to the side of the road so any following traffic may pass.

Safety Precautions For Truck Mounted Units:

- Comply with state and local laws governing highway safety and movement of machinery on roadways.

Safety Precautions For Hydraulic System:

- Check hydraulic tubes, hoses and fittings for damage and leakage. Never use hands to check for leaks. Hydraulic tubes and hoses must be properly routed and have adequate support and secure clamps. Tighten or replace any parts that show leakage.
- Always clean fluid spills. Do not use gasoline or diesel fuel for cleaning parts. Use commercial nonflammable solvents.

5.2 SAFETY SIGNS



Read all safety signs on the Forage Box and in this manual. Keep all safety signs clean and replace any damaged or missing safety signs before operating the equipment. Do Not remove any safety signs. Safety signs are for operator protection and information.

FRONT OF FORAGE BOX

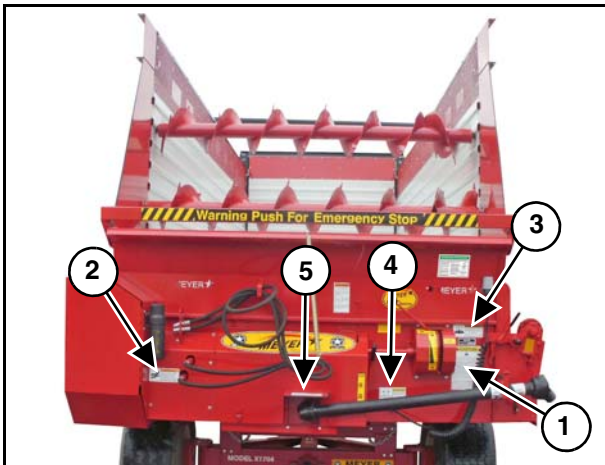

PART NO. 46-8500-7



PART NO. 46-0001-35

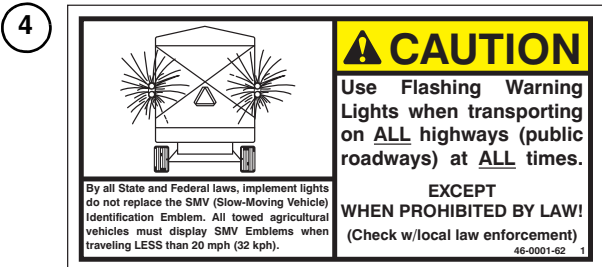

PART NO. 46-0001-62 (Pull Type Only)



PART NO. 46-0004-2

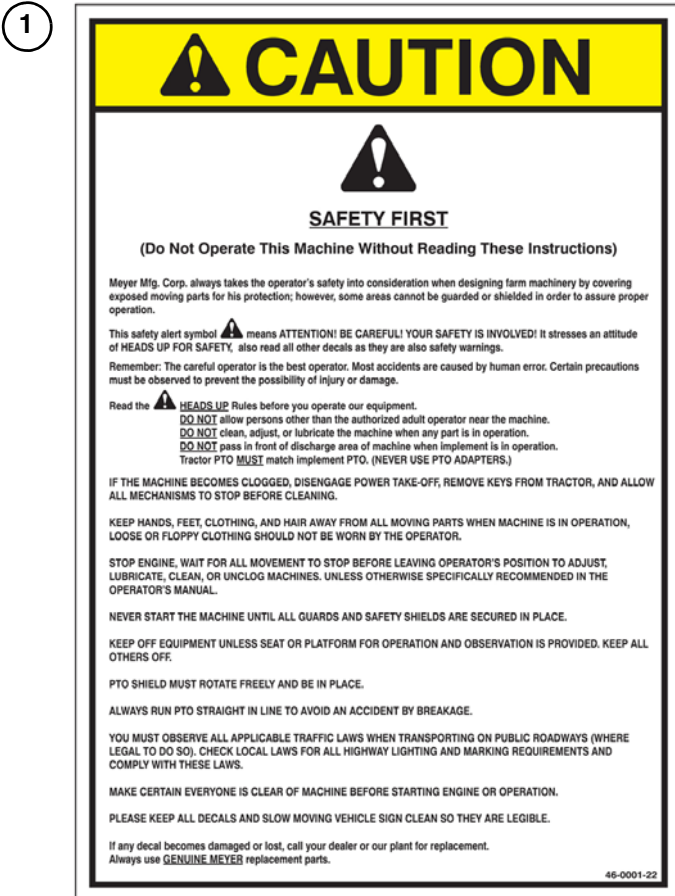

PART NO. 46-0001-22

Right Front Side

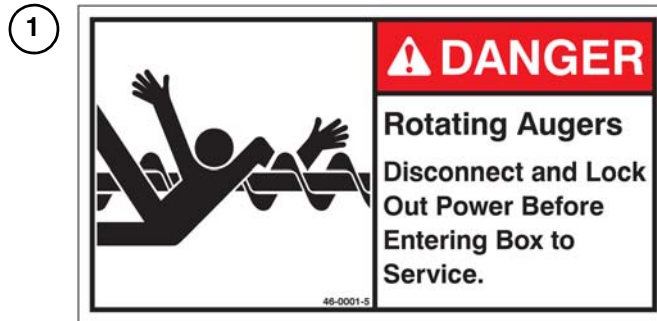
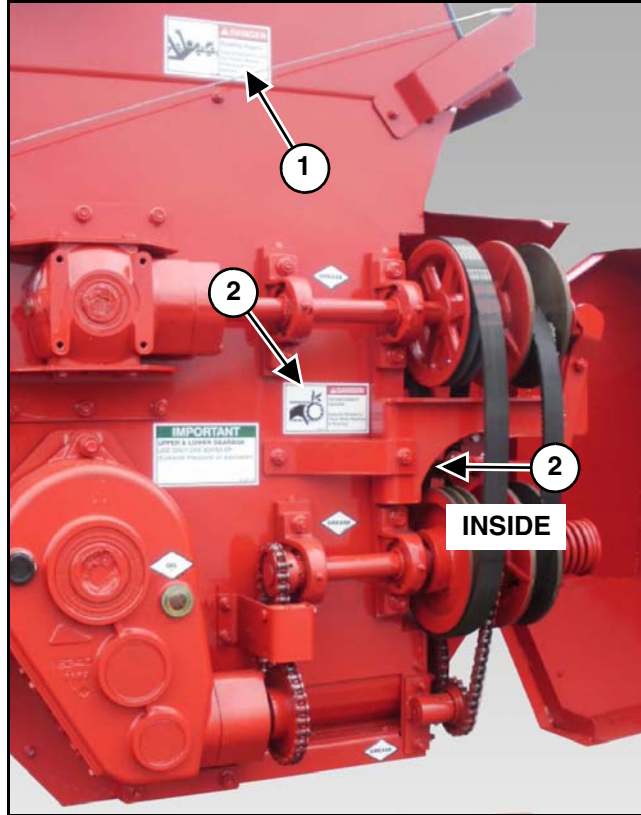

PART NO. 46-0001-5



PART NO. 46-0001-26

LEFT SIDE OF FORAGE BOX

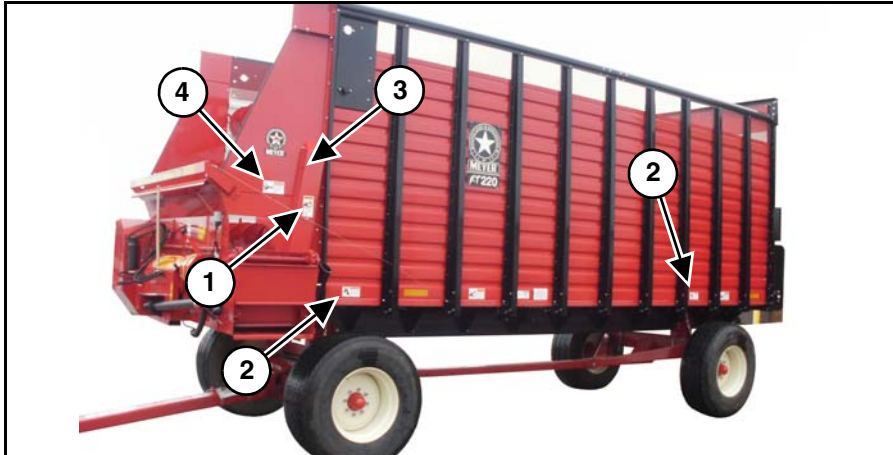

PART NO. 46-0001-33



PART NO. 46-0001-20



(Located Under Shield)

PART NO. 46-0001-26

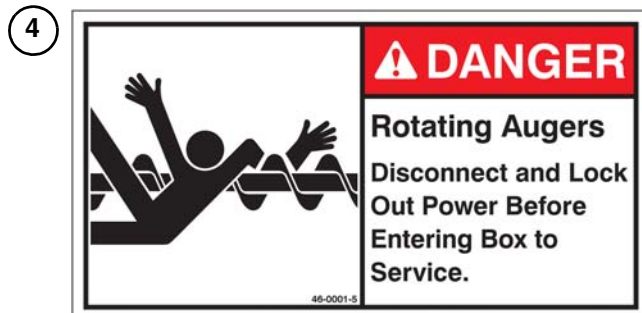

PART NO. 46-0001-5

RIGHT SIDE OF FORAGE BOX

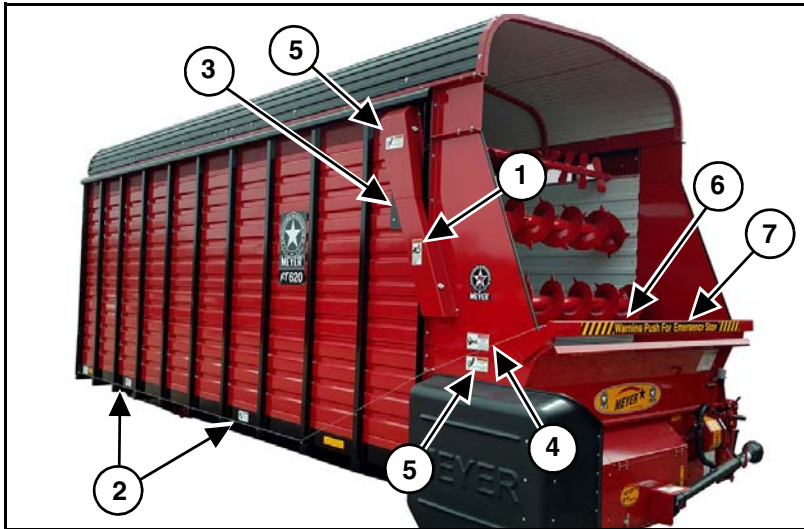

PART NO. 46-0001-33



PART NO. 46-0001-20



(Located Under Shield) PART NO. 46-0001-26



PART NO. 46-0001-5



PART NO. 46-0001-4



PART NO. 46-0001-14



PART NO. 46-0001-15

FRONT (UNDER SHIELD)



PART NO. 46-0001-26

FRONT OF FORAGE BOX



OPERATING PROCEDURE

NOTE: The VARIABLE SPEED, AUGER CLUTCH, and OUTFEED CLUTCH levers must be in their "STOP" positions when engaging and disengaging the PTO drive shaft (or optional hydraulic drive). **All forage box control lever selections are to be made while the PTO (or hydraulic) power is in operation.** If the control levers are engaged before power is applied, damage may occur to the VARIABLE SPEED drive and the OUTFEED CLUTCH drive. Failure to follow correct operating procedures may cause equipment damage and void the manufacturer's warranty.

1. Park the forage box so the discharge cross conveyor is in alignment with the bagger/blower hopper. Park the forage box and tractor in a straight line to prevent wearing of PTO drive shaft joints. If equipped with a cross conveyor extension, lower it down for unloading.
2. Check that the OUTFEED CLUTCH lever is in the "STOP" position, and the AUGER CLUTCH & VARIABLE SPEED levers are in their "STOP" positions.
3. Slowly engage the tractor PTO and set the engine speed from 1300-1500 RPM, which should give a PTO speed of 300-375 RPM.
4. Intermittently engage the OUTFEED CLUTCH lever in the "RUN" position and allow the cross conveyor to empty out any accumulation of forage in the front conveyor of the forage box. After the forage has emptied, fully engage the OUTFEED CLUTCH lever into the "RUN" position.
5. Intermittently engage the AUGER CLUTCH lever in the "RUN" position to allow the augers to empty out any accumulation of forage in the augers. After the augers have emptied, fully engage the AUGER CLUTCH lever into the "RUN" position.
6. Set the VARIABLE SPEED lever in a slow speed setting to start unloading. Increase speed of the VARIABLE SPEED lever to regulate rate of forage box unloading speed to match capacity of the bagger/blower. Use faster setting for main apron "cleanout" and small or partial loads.
7. When unloading is complete, slowly return the VARIABLE SPEED lever to the "STOP" position and then the AUGER CLUTCH lever to the "STOP" position. Then, disengage the OUTFEED CLUTCH lever to the "STOP" position. Idle down the tractor engine RPM and shut off the tractor PTO lever. Disconnect the PTO shaft from the tractor and secure it in the PTO hanger bracket at the front of the forage box. If the forage box is equipped with a cross conveyor extension, raise it up to the transport position.

When Rear Unloading:
All 3 control levers **MUST** be in the disengage ("STOP") position.

46-0001-164 1

PART NO. 46-0001-164

5.3 EMERGENCY SAFETY STOP



CAUTION

If the emergency stop mechanism does not function properly, do not operate the machine until the emergency stop mechanism has been properly repaired. Failure to heed may result in serious personal injury or death.

5.3.1 Emergency Stop Trip Locations

The “Warning Push For Emergency Stop” bar (Item 1) is located on the front of the forage box.

Emergency stop trip cables (Item 2) connected to the “Warning Push For Emergency Stop” pushbar extend along both sides of the forage box.

5.3.2 Front Unload Emergency Stop Operation

Push up on the bar (Item 1) to shut down the forage box in an emergency.

Pull on the trip cables (Item 2) to shut down the forage box in an emergency.

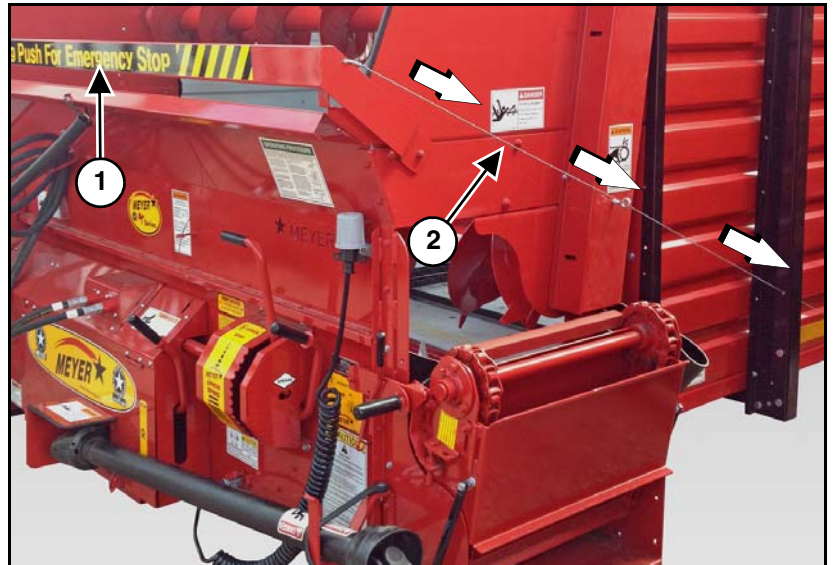

NOTE: The emergency stop mechanism DOES NOT STOP the PTO drive shaft.

5.3.3 Resetting the Emergency Stop



CAUTION

Shutoff and lockout power before performing machine service, adjusting, maintaining, or clearing an obstruction from this machine. Refer to section 5.4 SHUTOFF & LOCKOUT POWER.



CAUTION

Do not reset the emergency stop mechanism until all bystanders, tools and other objects have been cleared from the forage box. Failure to heed may result in serious personal injury or death.

To reset the emergency stop mechanism, fully engage the INDEPENDENT OUTFEED CLUTCH control lever into the “RUN” position.

Test the emergency stop mechanism frequently for front unloading operations using the push bar and trip cables at the rear most point of the box, to be assured that the emergency stop mechanism is in proper operating condition and can be shutdown in the event of an emergency.

NOTE: Always keep excessive slack out of the emergency stop trip cables.

5.4 SHUTOFF & LOCKOUT POWER

Any individual that will be adjusting, servicing, maintaining, or clearing an obstruction from this machine needs to ensure that this machine stays safely “OFF” until the adjustment, service, or maintenance has been completed, or when the obstruction has been cleared, and that all guards, shields, and covers have been restored to their original position. The safety of all individuals working on or around this machine, including family members, are affected. The following procedure will be referred to throughout this manual, so be familiar with the following steps.

5.4.1 Shutoff & Lockout Power Recommendations

1. Think, Plan and Check

- a. **Think** through the entire procedure and identify all the steps that are required.
- b. **Plan** what personnel will be involved, what needs to be shut down, what guards / shields need to be removed, and how the equipment will be restarted.
- c. **Check** the machine over to verify all power sources and stored energy have been identified including engines, hydraulic and pneumatic systems, springs and accumulators, and suspended loads.

2. **Communicate** - Let everyone involved, including those working on or around this machine, that work is being done which involves keeping this machine safely “OFF”.

3. Power Sources

- a. **LOCKOUT** - Shut off engines and take the key, or physically lock the start/on switch or control. Disconnect any power sources which are meant to be disconnected (i.e. electrical, hydraulic, and PTO of pull-type units).
- b. **TAGOUT** - Place a tag on the machine noting the reason for the power source being tagged out and what work is being done. This is particularly important if the power source is not within your sight and/or will need to be isolated for a longer period of time.

4. **Stored Energy** - Neutralize all stored energy from its power source. Ensure that this machine is level, set the parking brake, and chock the wheels. Disconnect electricity, block moveable parts, release or block spring energy, release pressure from hydraulic and pneumatic lines, and lower suspended parts to a resting position.

5. **Test** - Do a complete test and personally double check all of the above steps to verify that all of the power sources are actually disconnected and locked out.

6. **Restore Power** - When the work has been completed, follow the same basic procedures, ensuring that all individuals working on or around this machine are safely clear of the machine before locks and tags are removed and power is restored.

IMPORTANT

It is important that everyone who works on this equipment is properly trained to help ensure that they are familiar with this procedure and that they follow the steps outlined above. This manual will remind you when to Shutoff & Lockout Power.

6.0 PRE-OPERATION



DO NOT allow anyone to operate, service, inspect or otherwise handle this forage box until all operators have read and understand all of the instructional materials in this Operator's And Parts Manual and have been properly trained in its intended usage.

Verify that the forage box is securely fastened to the tractor / truck.

Verify that all electrical / hydraulic connections and bolts / hardware are tight and securely fastened before operating the forage box.

Always keep all shields and guards in place and securely fastened.

Keep hands, feet and clothing away.

Wear safety glasses to prevent eye injury when any of the following conditions exist:

- **When fluids are under pressure.**
- **Flying debris or loose material is present.**
- **Tools are being used.**

6.1 PRODUCT INSPECTION



Hydraulic fluid escaping under pressure can have sufficient force to cause injury. Keep all hoses and connections in good serviceable condition. Failure to heed could result in serious personal injury or death.

Before operating the forage box for the first time and each time thereafter, check the following items:

1. Check that all safety signs are in good and legible condition.
2. Inspect the forage box for proper adjustments. (See 8.2 ADJUSTMENTS on page 41.)
3. Lubricate the equipment. (See 8.1 LUBRICATION on page 37.)
4. Make sure that all guards and shields are in place, secured and functioning as designed.
5. Check condition of all hydraulic components for leaks. Repair or replace as required.
6. Check the gear box oil level. (See 8.1 LUBRICATION on page 37.)
7. Inspect the condition of safety lighting. Repair or replace as required.
8. Check to see that no obstructions are present in the forage box. Be sure that there are no tools laying on or in the forage box.
9. Verify that all electrical and hydraulic connections are tight and secure before operating.
10. Watch for any worn or cracked welds. If found, have qualified personnel repair immediately, replacement is necessary.
11. Check all bearings for wear. Replace as needed.

6.2 LIGHT HOOK-UP

Truck Mounted Models: A 4 pin electrical socket is provided to connect the electrical control plug from your truck. This will operate signal, tail, clearance and brake lights.

NOTE: Depending on make and model of the truck, it may be necessary to install a light converter. (Meyer part #56-0028). The converter allows signal lights and brake lights to operate according to DOT Lighting Standards.

6.3 PTO HOOK-UP

This forage box is to be operated with 540 RPM PTO ONLY. No PTO adapter may be used to alter speed or geometry. Set your tractor drawbar to conform to the standard dimensions as shown on the following illustration. This will ensure that the PTO drive shaft will not be over extended.

Adjust the tractor's drawbar in / out, until the center of the hitch pin hole matches the correct PTO set up. See your tractor's owner's manual for correct adjustment procedures (Item 2).

The distance between center of the tractor PTO shaft and drawbar should be between 6 - 12 inches (8 inches is recommended) (Item 1).

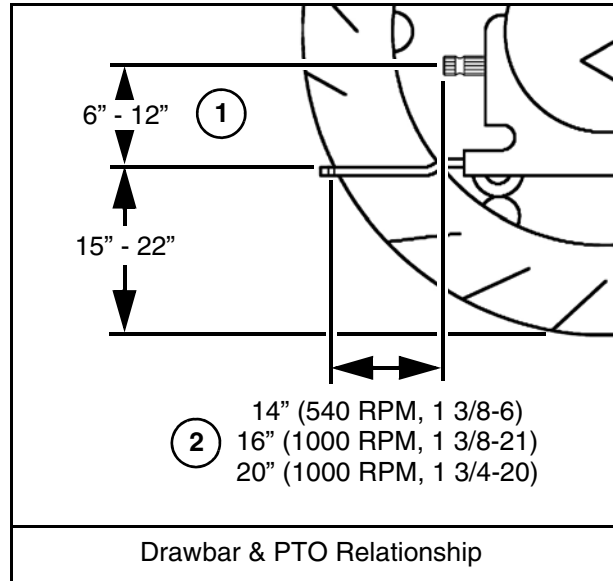

Do not operate without PTO guard on machine and on tractor. Maintain PTO drive shaft guards in operating condition. Replace guards if damaged or not turning freely. Failure to heed may result in serious personal injury or death.

NOTE: The PTO horsepower and / or hydraulic requirements may not reflect adequate tractor size for towing the machine. Refer to Tractor Weight Requirements 3.9.3 for these recommendations and transporting section for additional tractor and towing requirements.



Do not exceed maximum PSI or a motor failure could result.

6.4 HYDRAULIC HOOK-UP

Truck & Tractor hydraulic system should be capable of 25 GPM @ 3000 PSI peak pressure. If truck mounted, install a relief valve set at 3000 PSI. Engine RPM should be 1500 RPM. Set up hydraulic system on Truck mounted units with a minimum of a 30 gallon reservoir. 3/4" NPT hydraulic hookup.

Call the factory for further information.

NOTE: The PTO horsepower and/or hydraulic requirements may not reflect adequate tractor size for towing the machine. Refer to Tractor Weight Requirements 6.9.3 for these recommendations and transporting section for additional tractor and towing requirements.

IMPORTANT

Do not exceed maximum PSI or a motor failure could result.

6.5 HITCHING TO TRACTOR

Move to the operator's position, start the engine and release the parking brake.



WARNING

Do not allow anyone to stand between the tongue or hitch and the tractor when backing up to the Forage Box.

Move the tractor in front of the forage box. Slowly move the tractor backwards towards the forage box and align the drawbar with the implement's hitch.

NOTE: Lower or raise the forage box jack to properly align the drawbar and hitch.

Fasten the forage box hitch to the tractor drawbar with a properly sized hitch pin with safety retainer. (Reference ANSI/ASABE AD6489-3 Agricultural vehicles - Mechanical connections between towed and towing vehicles - Part 3: Tractor drawbar.) (See your Trailer / Chassis / Wagon manual for further details.)

Connect the tractor half of the PTO drive shaft assembly. The PTO must be locked securely to the tractor output shaft and the implement half of the PTO drive shaft assembly must be locked securely to the mixer drive line.

Before operation and after hitching the tractor to the implement, connect the hydraulic hoses and light cord to the tractor. Connect any optional equipment as needed.

6.6 START-UP AND SHUT-DOWN

CAUTION

DO NOT allow anyone to operate, service, inspect or otherwise handle this forage box until all operators have read and understand all of the instructional materials in this Operator's And Parts Manual and have been properly trained in its intended usage.

Before operating the forage box, look in all directions and make sure no bystanders, especially small children are in the work area.

WARNING

Disengage the hydraulic power, engage the machine's parking brake, stop the engine and make sure all moving components are completely stopped before connecting, disconnecting, adjusting or cleaning this equipment.

Always keep all shields and guards in place and securely fastened.

Keep hands, feet and clothing away.

6.6.1 Start-Up

Check that the INDEPENDENT OUTFEED CLUTCH (Item 1) control lever is in the "Stop" position and the VARIABLE SPEED (Item 2) & HI-LO RANGE (Item 3) control levers are in the "Neutral" positions. If equipped with a cross conveyor extension, lower it down.

Enter the tractor or truck and start the engine.

Increase engine RPM to 1500.

Slowly engage the tractor PTO and set the engine speed from 1300 - 1500 RPM, which should give a PTO speed of 300 - 375 RPM.

Exit the tractor.

Approach the operator's position on the front left side of the forage box ONLY by walking along the left side of the tractor.

Slowly engage the OUTFEED CLUTCH lever (Item 1) in the "RUN" position.

Slowly engage the AUGER CLUTCH lever (Item 2) in the "RUN" position.

Set the VARIABLE SPEED lever (Item 3) in a slow speed setting.

6.6.2 Shut-Down

Slowly return the VARIABLE SPEED lever to the "STOP" position.

Slowly return the AUGER CLUTCH lever to the "STOP" position.

Disengage the OUTFEED CLUTCH lever to the "STOP" position.

Idle down the tractor engine RPM.

Disengage the PTO drive shaft and turn the tractor "OFF".

If the forage box is equipped with a cross conveyor extension, raise it up to the transport position and securely latch it before traveling on roadways.

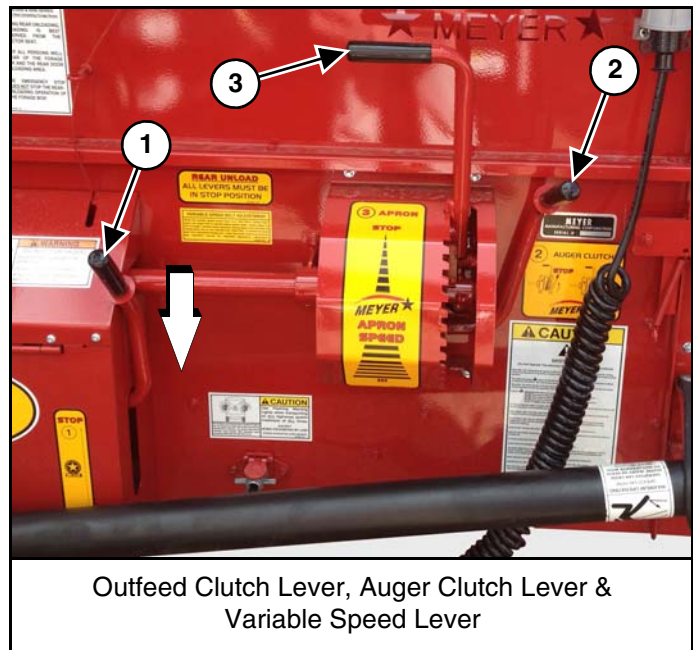

Outfeed Clutch Lever, Auger Clutch Lever & Variable Speed Lever

6.7 OPERATIONAL CHECKS



CAUTION

Shutoff and lockout power before performing machine service, adjusting, maintaining, or clearing an obstruction from this machine. Refer to section 5.4 SHUTOFF & LOCKOUT POWER.

DO NOT allow anyone to operate, service, inspect or otherwise handle this spreader until all operators have read and understand all of the instructional materials in this Operator's And Parts Manual and have been properly trained in its intended usage.

Before operating the forage box, look in all directions and make sure no bystanders, especially small children are in the work area.



WARNING

Always keep all shields and guards in place and securely fastened. Keep hands, feet and clothing away.



DANGER

Make certain all personnel are clear of the forage box and the rotating spinners or beaters before applying power. Failure to heed may result in serious personal injury or death.

Before running material through the forage box for the first time and each time thereafter, follow the steps listed below.

1. Make sure forage box is empty.
2. Follow the Start-Up procedure section 6.6.1.
3. Operate the forage box for approximately 5-10 minutes.
4. Follow the Shut-Down procedure section 6.6.2.
5. Check drive components to be sure components are not abnormally hot.
6. Check all hydraulic components for leaks.
7. Adjust and lubricate equipment as needed. (See 8.1 LUBRICATION) & (See 8.2 ADJUSTMENTS).

! CAUTION

AVOID SERIOUS INJURY OR DEATH

- Read and understand owner’s manual before using. Review safety precautions annually.
- Before operating the forage box, look in all directions and make sure no bystanders, especially small children are in the work area.
- No riders allowed when transporting.
- Do not drink and drive.
- Before moving, be sure required lights and reflectors are installed and working.
- Before maintenance or repair, stop vehicle, set parking brake, and remove ignition key.
- Place safety stands under frame and chock wheels before working on tires or chassis.
- Maintain wheel bolts at torque as recommended in the manual.
- If equipped with brakes, maintain proper adjustment.

! CAUTION

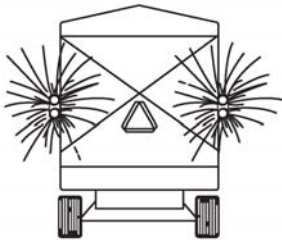

Pull-Type Units

- Use flashing warning lights when transporting on ALL highways (public roadways) at ALL times (Tractor towed models) EXCEPT WHEN PROHIBITED BY LAW! (Check w/local law enforcement)
- By all state and federal laws, implement lights do not replace the SMV (Slow-Moving Vehicle) identification emblem. All towed agricultural vehicles must display SMV emblems when traveling LESS than 20 mph (32 kph).
- Check for traffic constantly. Be sure you can see that no one is attempting to pass you and that all traffic is sufficiently clear from you before making any turns.
- Securely attach to towing unit. Use a high strength appropriately sized hitch pin with mechanical retainer and attach safety chain.
- Do not exceed 20 mph (32 kph). Slow down for corners and rough terrain.

! WARNING



To Prevent Serious Injury Or Death

- Keeps hands and body out of the hitch area when attaching towing vehicle.
- Keep body clear of crush point between towing vehicle and load.

! WARNING

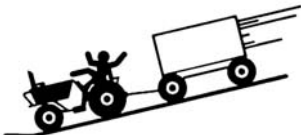

To Prevent Serious Injury Or Death

- Shift to lower gear before going down steep grades.
- Avoid traveling on slopes or hills that are unsafe.
- Keep towing vehicle in gear at all times.
- Never exceed a safe travel speed (which could be less than 20 MPH.).

WARNING

You must observe all applicable traffic laws when transporting on public roadways. Check local laws for all highway lighting and marking requirements. Failure to heed could result in serious personal injury or death.

WARNING

(Tractor Powered) Do not low at speeds in excess of 20 mph. Failure to heed could result in serious personal injury or death.

IMPORTANT

Verify that the fold down cross conveyor extension (if equipped), is folded up (raised position) to reduce transport width.

IMPORTANT

The running gear on tractor pulled models may be equipped with a telescoping tongue for convenience to hitch up. Always back up and lock this tongue in the operating position after hitching.

IMPORTANT

If you will travel on public roads and it is legal to do so, you must know all rules governing such operation. This will include lighting and brake requirements in addition to traffic rules.

An Optional Highway Lighting Package is available to assist in meeting these requirements. See your Meyer Dealer for Details.

6.8.1 Fold Down Cross Conveyor Extension

Always disconnect the PTO driveline from the tractor and place in the PTO storage bracket (Item 1) before transporting. Failure to do this may result in equipment damage.

Always transport with the fold down cross conveyor extension (Item 2) folded up.

Disconnect the hydraulic hoses from the tractor and place in the storage brackets (Item 3) before transporting.



6.9.1 Safety Chain



A safety chain must be installed to retain the connection between the tractor (or other towing vehicle) and implement whenever traveling on public roads in case the hitch connection would separate.

The chain must be of adequate size to hold the weight of the loaded forage box. See your ag cart or wagon owner/operator's manual and parts book, which is also available at www.meyermfg.com.

NOTE: If using a grab hook at the end(s) of the chain to secure the chain to itself, a hook latch (Item 1) must be installed.

The length of the safety chain is not to be any longer than necessary to turn without interference. If any chain links or attachment hardware are broken or stretched, repair before using. Store chain so it does not corrode or become damaged. Do not use this chain for other implements because the strength and length of the chain may not be adequate. Identify this chain for use on this particular forage box.

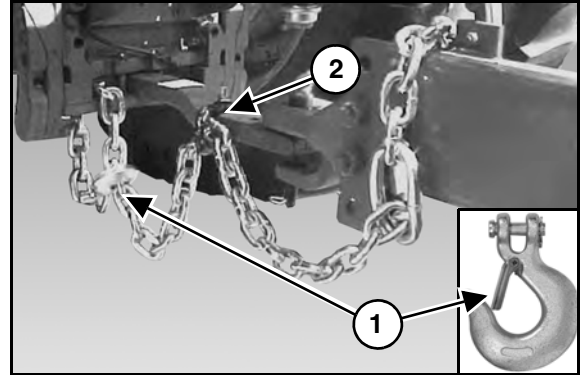

NOTE: Do not use the intermediate support (Item 2) as the attaching point.

IMPORTANT

If you do not have a safety chain, or a replacement safety chain is needed, see your local Meyer dealer and do not operate on public roads until you are able to travel with the safety chain properly installed.

6.9.2 Brake Information

See your trailer / chassis manual for brake and braking information.

6.9.3 Tractor Towing Size Requirements

Use the following charts to help calculate the minimum tractor weight when towing without implement brakes. The minimum tractor weight, up to 20 mph (33 kph) needs to be 2/3's of the box Gross Weight (GW). Gross Weight is calculated by the empty weight of the box and undercarriage combined added to the Load Weight. Then take the Gross Weight and multiply it by 0.667 and you will get the Minimum Required Weight of the Tractor.

Gross Weight

FORAGE BOX WEIGHT, EMPTY (LBS)		UNDERCARRIAGE WEIGHT (LBS)		LOAD (LBS)		GROSS WEIGHT (GW) (LBS)
	+		+		=	GW
	+		+		=	

Minimum Required Weight of the Tractor

2/3		GROSS WEIGHT (GW) (LBS)		MINIMUM TRACTOR WEIGHT (LBS)
0.667	x	GW	=	TW
	x		=	

MATERIAL ESTIMATED WEIGHT PER CUBIC FOOT	
MATERIAL	LBS / CU. FT.
Soybeans	47 lbs.
Cotton Seed (Dry)	20 lbs.
Corn (Shelled)	45 lbs.
Corn Silage	30 lbs.
Haylage	20 lbs.
Sawdust	17 lbs.
Source: SAE D384.2	

Tractor PTO Horsepower Requirements:

The PTO horsepower requirements may not reflect tractor size for towing the machine. Refer to tractor weight requirements for these recommendations and safety section for additional tractor and towing requirements.



7.0 OPERATION



DO NOT allow anyone to operate, service, inspect or otherwise handle this forage box until all operators have read and understand all of the instructional materials in this Operator's And Parts Manual and have been properly trained in its intended usage.

Before operating the forage box, look in all directions and make sure no bystanders, especially small children are in the work area.

Do not climb or step on any part of the forage box at any time.

Turn on level ground. Slow down when turning.

Go up and down slopes, not across them.

Keep the heavy end of the machine uphill.

Do not overload the machine.

Check for adequate traction.



7.1 LOADING



Shutoff and lockout power before performing machine service, adjusting, maintaining, or clearing an obstruction from this machine. Refer to section 5.4 SHUTOFF & LOCKOUT POWER.



Overloading may cause failure of axles, tires, structural members, hitches, loss of vehicle control. **DO NOT** exceed maximum gross weight. (See 9.0 SPECIFICATIONS on page 51.)



Filling the forage box evenly from the front to rear will ensure there is downward force on the tractor hitch and provide traction for the tractor wheels.

NOTE: Heaping material over the sides of the box will add a significant amount of weight to the load.

NOTE: Overloading can have detrimental effects on the integrity of the implement and it's safe use. Some materials such as soybeans may not be able to be filled to struck level. Overloading will void warranty and increase risk to the operator's safety. Always be aware of your gross weight.

MAXIMUM FORAGE BOX GROSS WEIGHT	
MODEL	LBS

MATERIAL ESTIMATED WEIGHT PER CUBIC FOOT	
MATERIAL	LBS / CU.FT.
Soybeans	47 lbs.
Cotton Seed (Dry)	20 lbs.
Corn (Shelled)	45 lbs.
Corn Silage	30 lbs.
Haylage	20 lbs.
Sawdust	17 lbs.
Source: SAE D384.2	

NOTE: Maximum Gross Weight is the lesser value between the Implement, chassis, or tires

NOTE: DO NOT fill the cross conveyor unloading area with forage to gain extra capacity. Filling the front unloading unit puts unnecessary pressures and strains on the cross conveyor and auger drive.

7.2 NO ROOF IMPLEMENTS

Drive alongside the loading vehicle. Fill the forage box evenly to properly distribute the load while loading. When dumping into the box with an end-loader, center the bucket just forward of the axle to properly distribute the load while loading.

7.3 UNLOADING

CAUTION

Shutoff and lockout power before performing machine service, adjusting, maintaining, or clearing an obstruction from this machine. Refer to section 5.4 SHUTOFF & LOCKOUT POWER.

Never enter the forage box without shutting power “OFF” to the machine. Refer to section 5.4 SHUTOFF & LOCKOUT POWER.

Never use “LIVE” power to aid in the clean-out of a clogged machine.

IMPORTANT

The unloading process described is to be performed by the operator alone. This will eliminate unexpected “start-ups” and minimize other hazards that could result by more than one person in control.

Enter the tractor / truck, start the engine, release the parking brake.

Move the forage box into position and park so that the discharge cross conveyor opening is in alignment with the bagger / blower hopper. If equipped with a cross conveyor extension, lower it down before pulling in front of the blower.

NOTE: Always park the forage box and unloading tractor in a straight line. Minimize the unloading angle on the PTO driveline to prevent wearing of universal joints when connected to the unloading tractor PTO.

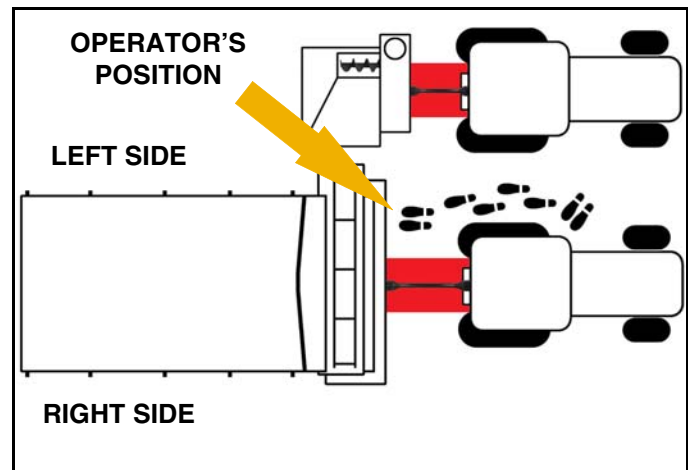

Place all tractor / truck controls in neutral, set the parking brake.

IMPORTANT

Do not approach the forage box from the right side of the machine (left hand unload). Approach the left front area of the forage box, as this is where the control levers are located. Standing in the operator position will not require crossing the PTO drive shaft at any time during the unloading operation.

WARNING



AVOID SERIOUS PERSONAL INJURY OR DEATH

- Do not step over the PTO driveline.
- Stay well clear of the PTO driveline at all times.
- Do not step up on any part of the forage box at any time.

Remove the PTO drive shaft from the forage box PTO storage bracket and connect it to the tractor PTO. Be sure the PTO yoke is securely locked to the tractor PTO. If using an optional hydraulic drive, couple the hydraulic hoses to the power supply.

Check that the INDEPENDENT OUTFEED CLUTCH (Item 1) control lever is in the “Stop” position and the VARIABLE SPEED (Item 2) & HI-LO RANGE (Item 3) control levers are in the “Neutral” positions.

Slowly engage the tractor PTO and set the engine speed from 1300 - 1500 RPM, which should give a PTO speed of 300 - 375 RPM.

Exit the tractor.

Approach the operator’s position on the front left side of the forage box ONLY by walking along the left side of the tractor.

NOTE: The VARIABLE SPEED, AUGER CLUTCH, and OUTFEED CLUTCH levers must be in their “STOP” positions when engaging and disengaging the PTO drive shaft (or optional hydraulic drive). All forage box control lever selections are to be made while the PTO (or hydraulic) power is in operation. If the control levers are engaged before power is applied, damage may occur to the VARIABLE SPEED drive and the OUTFEED CLUTCH drive. Failure to follow correct operating procedures may cause equipment damage and void the manufacturer's warranty.

Intermittently engage the OUTFEED CLUTCH lever (Item 1) in the “RUN” position and allow the cross conveyor to empty out any accumulation of forage in the front conveyor of the forage box. After the forage has emptied, fully engage the OUTFEED CLUTCH lever into the “RUN” position.

Intermittently engage the AUGER CLUTCH lever (Item 2) in the “RUN” position to allow the augers to empty out any accumulation of forage in the augers. After the augers have emptied, fully engage the AUGER CLUTCH lever into the “RUN” position.

Set the VARIABLE SPEED lever (Item 3) in a slow speed setting to start unloading. Increase speed of the VARIABLE SPEED lever to regulate rate of forage box unloading speed to match capacity of the bagger / blower. Use faster setting for main apron “cleanout” and small or partial loads.

When unloading is complete, slowly return the VARIABLE SPEED lever to the “STOP” position and then the AUGER CLUTCH lever to the “STOP” position. Then, disengage the OUTFEED CLUTCH lever to the “STOP” position.

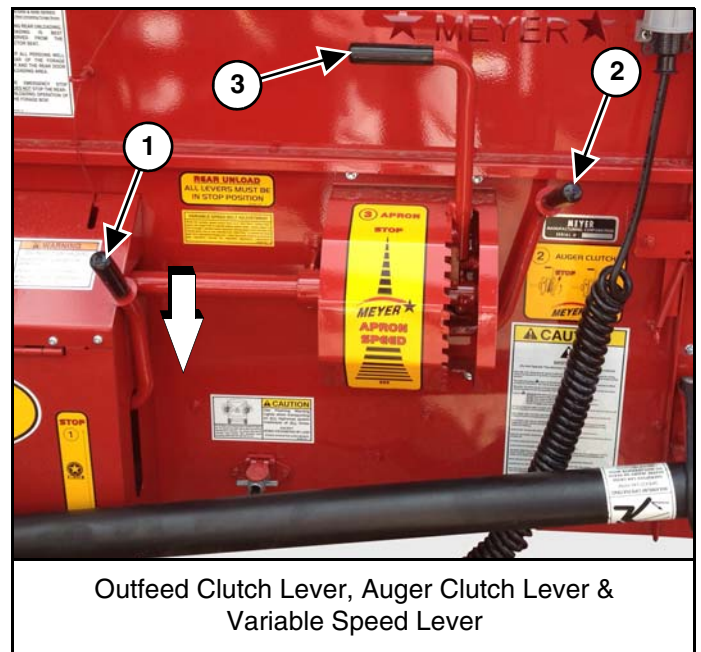

Outfeed Clutch Lever, Auger Clutch Lever & Variable Speed Lever

IMPORTANT

Control lever settings must be made while the forage box front unloading unit is in operation. Moving the control levers with the unloading unit stopped will be difficult or impossible. This may cause equipment damages and may void the manufacturer’s warranty.

Idle down the tractor engine RPM. Disengage the PTO drive shaft and turn the tractor “OFF.” When all movement has stopped, disconnect the PTO drive shaft from the forage box unloading tractor and return it to the PTO storage bracket. Secure the PTO drive shaft into the PTO storage bracket with the rubber tie down strap. Shut down the silo filling blower tractor and wait for all motion to stop. If the forage box is equipped with a cross conveyor extension, raise it up to the transport position and securely latch it before traveling on roadways.

The unloading process described is to be performed by the operator alone. This will eliminate unexpected “start-ups” and minimize other hazards that could result by more than one person in control.

IMPORTANT

If the forage box becomes clogged, shut off all power to the forage box and wait until all rotating components are completely stopped. Refer to section 5.4 SHUTOFF & LOCKOUT POWER.

IMPORTANT

If any component fails, shut off all power to the forage box and move the forage box to a safe work area. Repair or replace damaged components before proceeding with unloading of the forage.

7.5 UNHOOKING THE TRACTOR

1. Park the implement on level ground. Put the tractor controls in neutral, set the parking brake, and turn the engine off before dismounting.
2. Place wheel chocks in front and in back of the implement wheels on opposite sides to prevent the implement from rolling after the tractor is unhooked.
3. Disconnect the PTO drive shaft from the forage box unloading tractor and return it to the PTO storage bracket. Secure the PTO drive shaft into the PTO storage bracket with the rubber tie down strap.
4. Remove the hydraulic hose ends from the tractor hydraulic ports and secure the hose ends on the front of the box to keep them clean.
5. Remove the light cords and any optional equipment connections.
6. Trailer Mounted Units: Remove the jack from the storage mount and install it on the hitch tongue. Crank the jack down until the hitch lifts off the tractor draw bar.



WARNING

Keep hands, legs and feet from under tongue and hitch until jack is locked into place.

7. Remove the hitch pin.
8. Unhook safety chain from tractor drawbar and intermediate support.
9. Slowly drive the tractor away from the implement.

8.0 MAINTENANCE

8.1 LUBRICATION



CAUTION

Shutoff & lockout power before performing machine service, adjusting, maintaining, or clearing an obstruction from the machine. Refer to section 5.4 SHUTOFF & LOCKOUT POWER.

IMPORTANT

Fluid such as hydraulic fluid, grease, etc. must be disposed of in an environmentally safe manner. Some regulations require that certain spills and leaks on the ground must be cleaned in a specific manner. See local, state and federal regulations for the correct disposal.

NOTE: Use a grease type that is composed of a high quality lithium complex or better, unless otherwise stated. We recommend using a #1 grade in colder temperatures or a #2 grade in warmer.

DAILY or every 10-20 loads:

- Grease the PTO driveline universal joints. Grease the PTO driveline telescoping shaft and tube (zerk accessible through the plastic guards).
- Grease front idler sprocket (Item 1). Wipe off excess grease from exterior.
- Grease moveable clutch sheaves (Item 2). Wipe excess from interior and exterior.
- Grease the idler pulley bearing (Item 3).

NOTE: Prevent oil and grease from getting on clutch sheave belt drive surface.

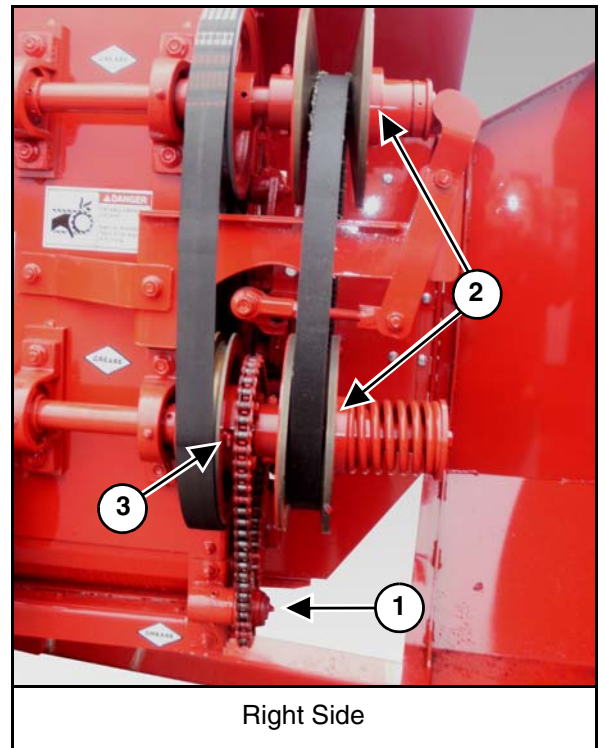

Equivalent Viscosity of ISO-VG Grades at 104°F and SAE Gear Lube Grades

ISO-VG Grade	SAE Gear Lube Grade
46	75W
100	80W-90
220	90
460	85W-140
1500	250

- Oil roller chain (Item 1) on main apron drive and roller chain (Item 2) on cross conveyor drive.

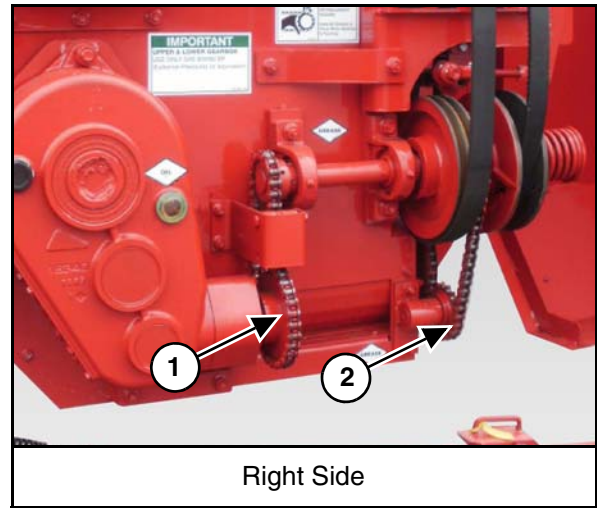

Right Side

- Oil roller chains on the middle and upper auger drive roller chains (Item 3) through slots provided in the chain shields.
- 4th auger option has an additional roller chain (Item 4) to be oiled through the slots provided in the chain shields.

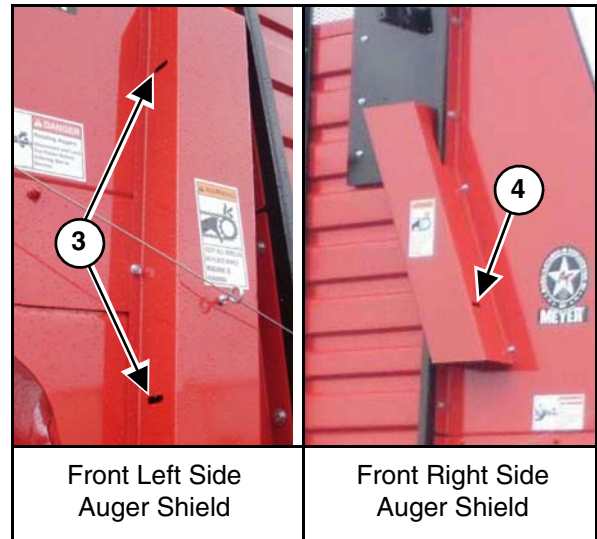

Front Left Side
Auger Shield

Front Right Side
Auger Shield

Monthly or every **100-150 loads**:

- Grease the variable speed control lever (Item 1).



Variable Speed Control Lever

- Grease the six main apron shaft bearings (Item 2) (three front, three rear).

NOTE: Front center bearing grease from zerk in left end frame. Not shown.

- Grease gear cluster shaft bearings (Item 3).
- Grease the four cross conveyor apron shaft bearings (Item 4) (both sides).
- Using the visual indicator (Item 5) on the front apron drive gearbox. The oil level should be at the top of the sight glass when parked on level ground.

Add EP 80-90 gear lube as needed (Lighter oil may be used in temperatures lower than 20° F.).

NOTE: Change oil in the gear box after the first season of use and yearly thereafter.

- Using the visual indicator (Item 6) on the auger drive upper gearbox. The oil level should be at the top of the sight glass when parked on level ground.

Add EP 80-90 gear lube as needed (Lighter oil may be used in temperatures lower than 20° F.).

NOTE: Change oil in the gear box after the first season of use and yearly thereafter.

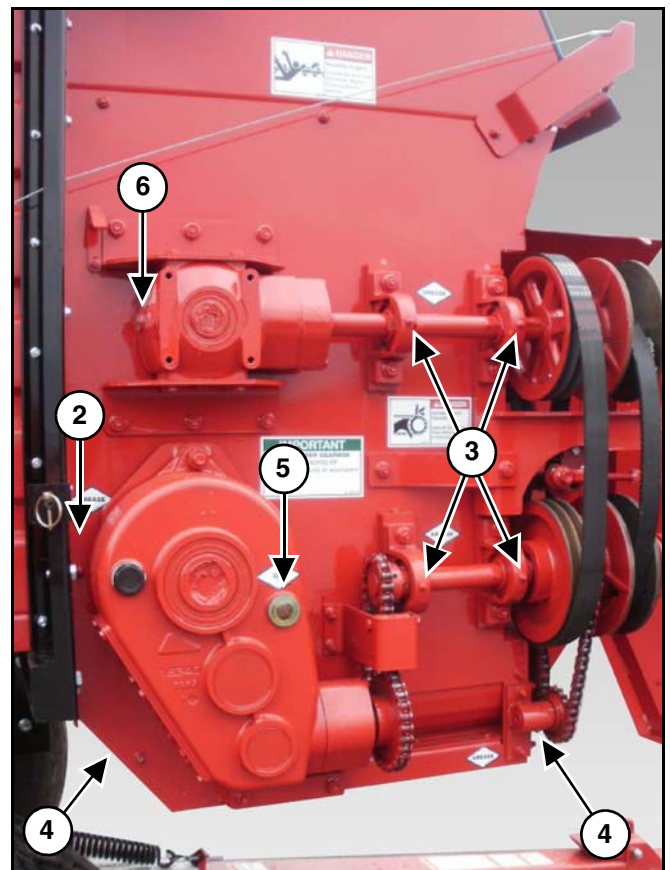

Front Right Side

- Grease thrust bearing (Item 1) using a needle point grease gun, turn the bearing while greasing.

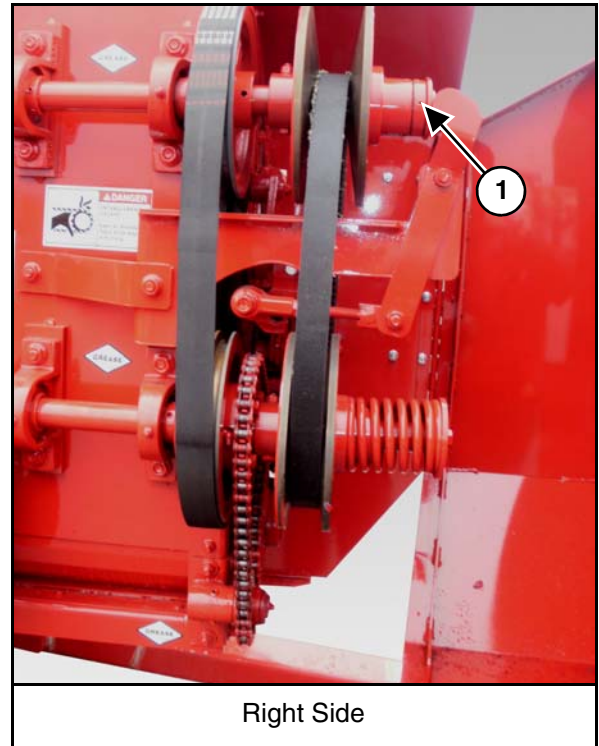

- Grease cross conveyor apron shaft bearings (Item 2).

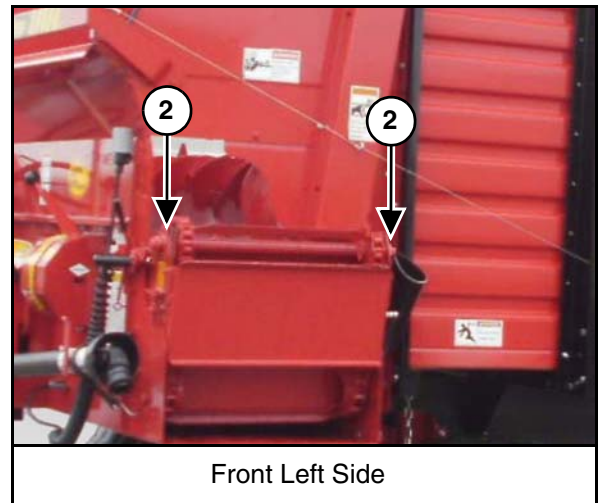

- Grease main apron shaft bearings (Item 3) (one fitting on back side of belt).

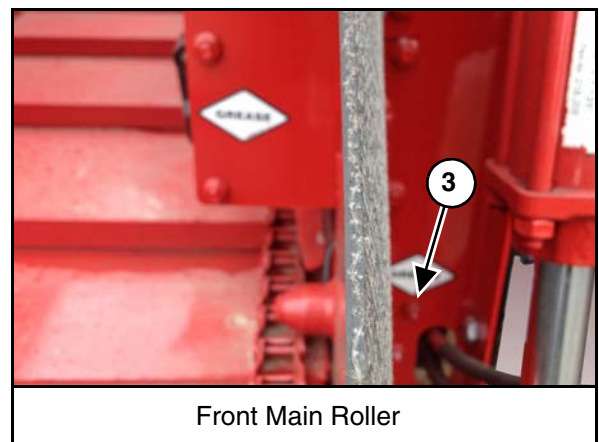

- Grease independent outfeed clutch handle pivot (Item 1) (under front shield).

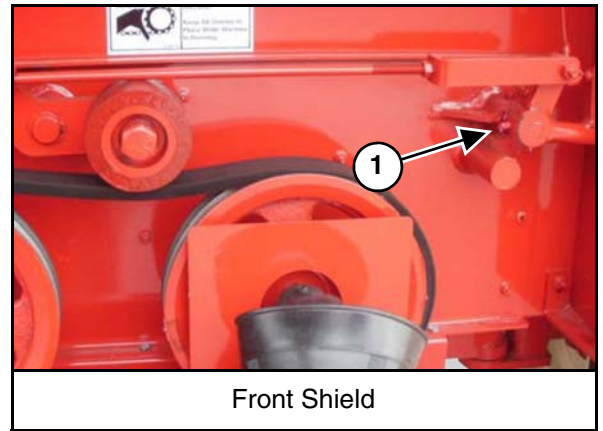

- Apply grease to the auger clutch tightener arm (Item 2) and the auger clutch pivot sleeve assembly (Item 3).

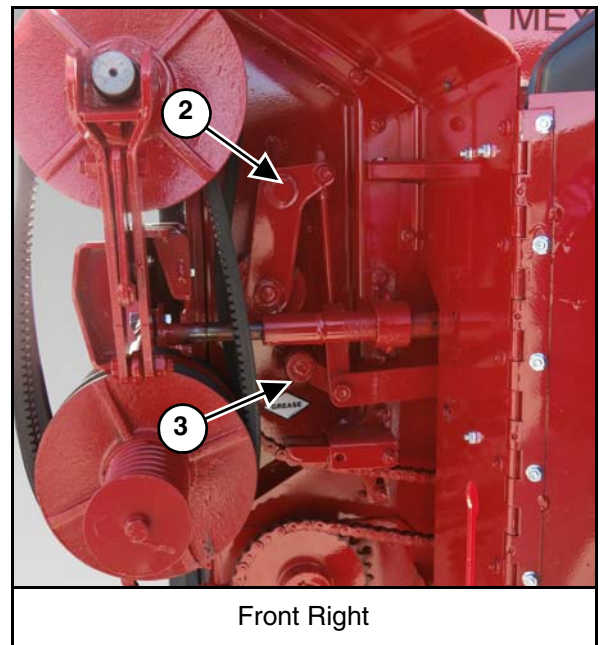

8.2 ADJUSTMENTS

8.2.1 Front Cross Conveyor every 100-150 Loads

Correct adjustment of the front cross conveyor occurs when 12" of chain, APRON SLAT does not touch the BOTTOM PAN of the cross apron return area at the discharge opening. To tighten the chain, loosen the four bolts securing the slotted bearing bracket at each side of the discharge opening. Tighten the chain by tightening the nut on the adjuster bolt. Adjust both sides equally. Retighten the bearing bracket bolts.

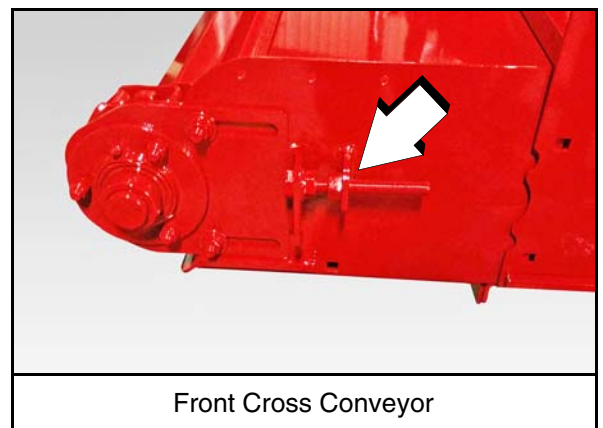

8.2.2 Main Apron Chains

After unloading the first ten loads from the front, check the main apron chain tension.

Correct adjustment on the main apron chains is when about (2') feet of chain does not touch the return slides at the rear of the forage box.

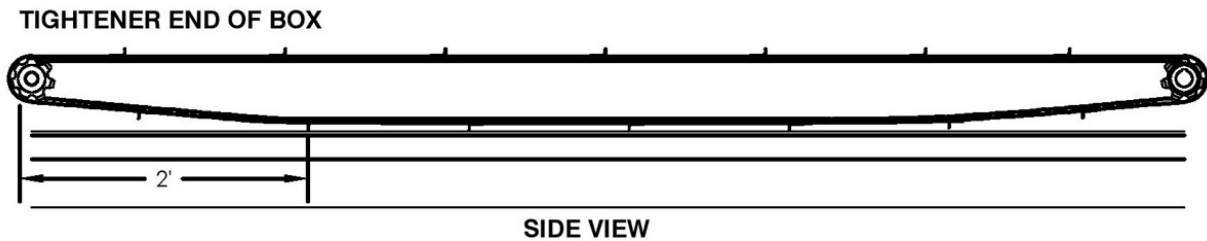

Tighten the adjuster bolts at each end of the rear sprocket shaft equally.

Each apron chain has its own idler shaft.

IMPORTANT

Initial wear in of chain will require adjustment to maintain proper chain tension. FAILURE TO MAINTAIN PROPER CHAIN TENSION MAY VOID WARRANTY.

Check chain tension daily for the next five days of operation, and weekly thereafter.

Locate the removable links by inspecting the chain and locating the section of links with cotter pins (Item 1).

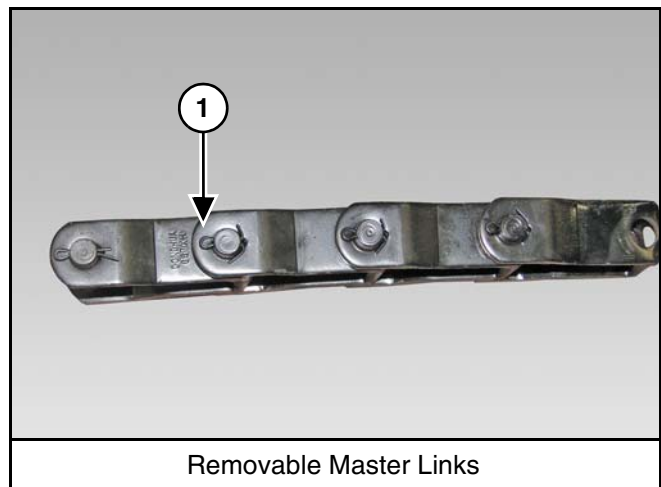

NOTE: If adjuster bolt(s) reaches maximum travel, remove equal links from each strand. Removable links are provided in the chain.

Removable master links are included in each of the four strands for shortening the chain after tightener travel is at its maximum. Remove a link from each of the four strands at the same time to assure proper timing, then re-adjust the tightener bolts (Item 1).

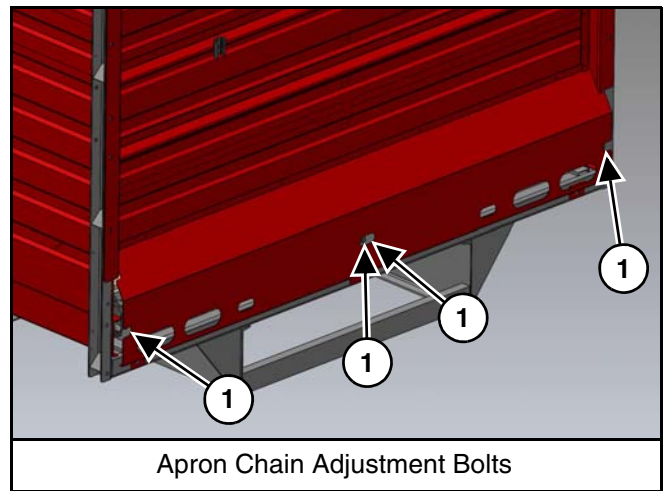

8.3 CLEAN-OUT PANEL

IMPORTANT

Clean out all debris / foreign material from this area to maintain proper cross conveyor chain operation.

Remove the three (3) wing nuts (Item 1) and remove the clean-out panel.

NOTE: One wing nut located behind sprocket (left).

There are two cleanout panels under the unit for cross apron clean out.

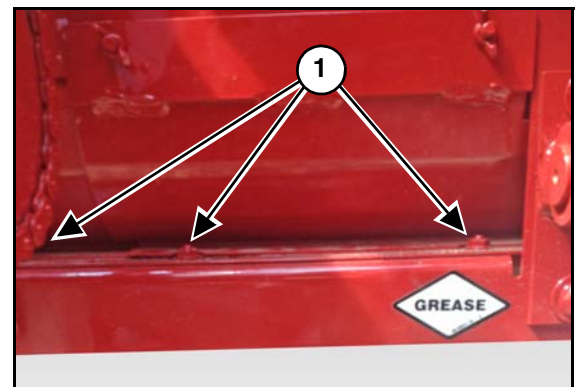

8.4 INDEPENDENT OUTFEED CLUTCH

8.4.1 Independent Outfeed Clutch Belt Replacement

1. Move the Independent Outfeed Clutch control lever to “STOP” (up).
2. Extend the PTO drive shaft out straight and lower the tractor end down to ground level.
3. Unlatch and raise the hinged top, front chain shield assembly.
4. Remove the clutch bottom bracket - “belt pan.”
5. Roll off the old Double V-Belt from the two pulleys.
6. Slide off the old belt down the length and over the end of the PTO drive shaft.
7. Install new Double V-Belt onto the two pulleys and check for proper engage, "RUN" tension. Adjust as needed.
8. Refasten the clutch bottom bracket - “belt pan” and the PTO input shaft cover.
9. Lower and latch close the hinged top, front chain shield assembly.
10. PTO drive shaft from ground level and return it to the PTO storage bracket.



8.4.2 Independent Outfeed Clutch Adjustment

Lengthen or shorten linkage bolt with jam nut to create moderate tension on the Double V-Belt when engaging the Independent Outfeed Clutch control lever into the “Run” position.

8.5 VARIABLE SPEED CONTROL

8.5.1 Variable Speed Belt Replacement

1. Shift the variable speed control lever to "NEUTRAL" (up).
2. Shift the range control lever to "NEUTRAL" (center).
3. Move the independent outfeed clutch control lever to "STOP" (up).
4. Lower the fold down cross conveyor extension (if equipped).
5. Open cluster shield plastic door.
6. Roll the old belt counter-clockwise off of the top sheaves starting at the 2:00 position.
7. Install the new belt around the lower sheaves and then roll clockwise onto the top sheaves starting at the 10:00 position.
8. Close and securely fasten the cluster shield plastic door.
9. Raise and latch the fold down cross conveyor extension (if equipped).

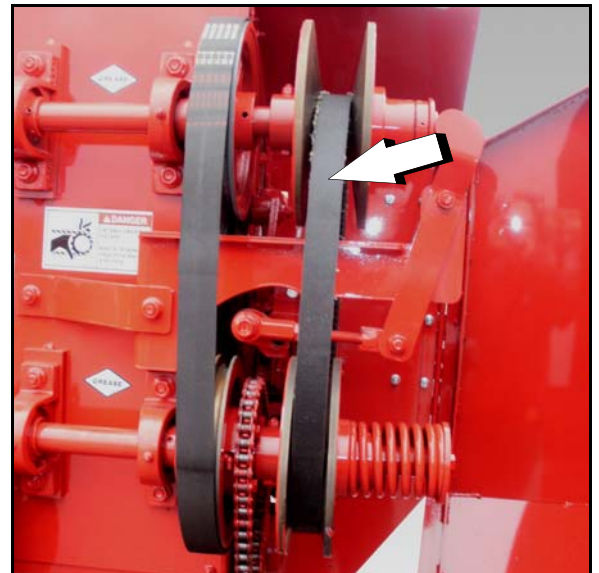

Variable Speed Belt

8.5.2 Variable Speed Control Adjustment

When the variable speed control lever is in "NEUTRAL", observe that the main aprons are not operating when under load (when wagon is full of forage). Variable speed operation should begin when the lever is moved down one or two notches from "NEUTRAL".

1. Set the variable speed control lever into neutral position.
2. While the box is running, observe the top shaft. When the belt is properly adjusted, the belt will not be driven when loaded.
3. To adjust, loosen the jam nut (Item 1) and turn the threaded rod:
 - A. Lengthen or un-thread the eyelet to set the base of the sheaves tight together.
 - B. Shorten or thread the eyelet to set the base of the sheaves further apart.
4. Tighten the jam nut.

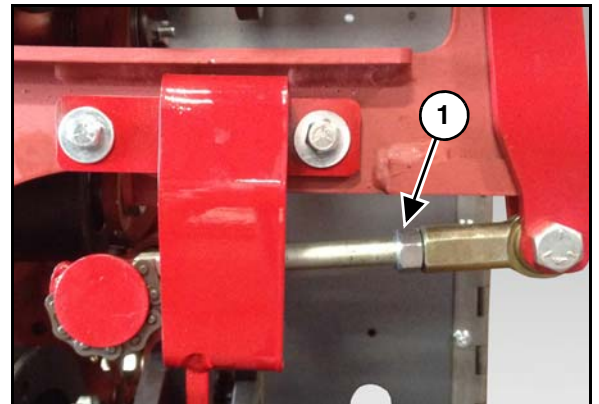

Variable Speed Belt

NOTE: Once the sheaves have been fully adjusted and the clean out has slowed to a slower than desired speed, belt replacement is necessary.

8.6 AUGER CLUTCH

1. Move the Auger Clutch control lever to “STOP” (up).
2. Open the cluster shield.
3. Remove the PTO drive chain (1) and the variable speed adjustment eye (2).
4. Loosen the auger clutch adjustment (3).
5. Roll off the old Double V-Belt from the two pulleys (4).
6. Install new Double V-Belt onto the two pulleys and check for proper engage, “RUN” tension. Adjust the tightener needed.
7. Reinstall the variable speed adjustment eye, and reinstall the drive chain.
8. Re-tension the auger clutch adjustment. (See 8.6.1 Auger Clutch Adjustment on page 46.)
9. Close and latch the cluster shield.

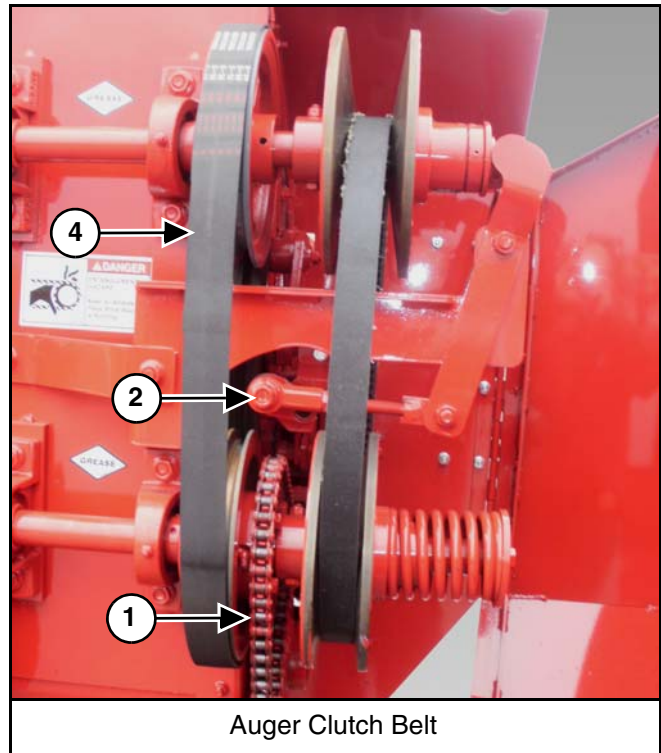

8.6.1 Auger Clutch Adjustment

Lengthen or shorten the linkage bolt with lock nut to create moderate tension on the Double V-Belt when engaging the Auger Clutch control lever into the “RUN” position. Adjustment must allow the belt to idle when not engaged.

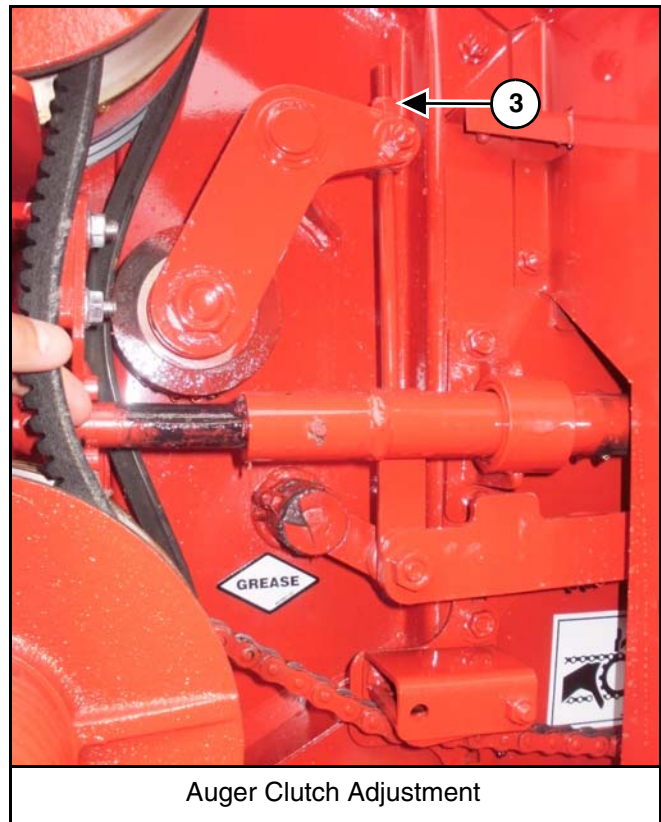

8.7 STORING THE FORAGE BOX

LOCKOUT / TAGOUT the machine / forage box when preparing for storage. (See 5.4 SHUTOFF & LOCKOUT POWER on page 22.)

Sometimes it may be necessary to store your Meyer forage box for an extended period of time. Below is a list of items to perform before storage.

- Fully empty the forage from the box. (See 7.0 OPERATION on page 33.)
- Thoroughly clean the equipment inside & out.
 - Clean out all materials built-up around the augers.
 - Clean the front cross conveyor on the top pan and in the lower pan (chain return).
 - Clean out the “clean-out” panel.
 - Clean the rear gate shield.
 - Clean the inside of the drive shields.
- Lubricate the equipment. (See 8.1 LUBRICATION on page 37.)
- Apply oil to the cross conveyor and main apron chains and inspect all forage box components for wear or damage. Repair and replace components as necessary.
- Make appropriate adjustments to equipment. (See 8.2 ADJUSTMENTS on page 41.)
- Place hydraulic hoses and 7-pin connector in the storage brackets (if equipped).
- Inspect the hitch and all welds on the equipment for wear and damage.
- Check for loose hardware, missing guards, or damaged parts.
- Check for damaged or missing safety signs (decals). Replace if necessary.
- Replace worn or damaged parts.
- Touch up all paint nicks and scratches to prevent rusting.
- Place the equipment in a dry protected shelter.
- Place the equipment flat on the ground.

8.8 RETURNING THE FORAGE BOX TO SERVICE

After the Meyer forage box has been in storage, it is necessary to follow a list of items to return the equipment to service.

- Be sure all shields and guards are in place.
- Lubricate the equipment.
- Connect to a truck (if required) and operate the truck and equipment, verify all functions operate correctly.
- Connect to a tractor (if required) and operate equipment, verify all functions operate correctly.
- Check for leaks. Repair as needed.
- Verify that all adjustments have been made.

8.9 REPLACEMENT PARTS



WARNING

Before servicing this equipment, ensure that all personnel, including family members are familiar with the equipment and the safety hazards that are present, along with the safety practices that should be observed while working in this equipment.



CAUTION

Inspect the chassis' axles, o-beams, spindles, tires, hitches & all safety shielding, safety signs and safety lighting regularly. These parts if not watched closely, may pose potential injury or death. If any part is found in need of repair, follow the SHUTOFF & LOCKOUT POWER recommendations and have qualified personnel repair immediately.

Any individual that will be adjusting, servicing, maintaining, or clearing an obstruction from this machine needs to ensure that this machine stays safely "OFF" until the adjustment, service, or maintenance has been completed, or when the obstruction has been cleared, and that all guards, shields, and covers have been restored to their original position. The safety of all individuals working on or around this machine, including family members, are affected. The following procedure will be referred to throughout this manual, so be familiar with the following steps.

8.9.1 Shutoff & Lockout Power Recommendations

1. Think, Plan and Check

- a. **Think** through the entire procedure and identify all the steps that are required.
- b. **Plan** what personnel will be involved, what needs to be shut down, what guards / shields need to be removed, and how the equipment will be restarted.
- c. **Check** the machine over to verify all power sources and stored energy have been identified including engines, hydraulic and pneumatic systems, springs and accumulators, and suspended loads.

2. **Communicate** - Inform everyone involved, including those working on or around this machine, that work is being done which involves keeping this machine safely "OFF".

3. Power Sources

- a. **LOCKOUT** - Shut off engines and take the key, or physically lock the start/on switch or control. Disconnect any power sources which are meant to be disconnected (i.e. electrical, hydraulic, and PTO of pull-type units).
- b. **TAGOUT** - Place a tag on the machine noting the reason for the power source being tagged out and what work is being done. This is particularly important if the power source is not within your sight and/or will need to be isolated for a longer period of time.

4. **Stored Energy** - Neutralize all stored energy from its power source. Ensure that this machine is level, set the parking brake, and chock the wheels. Disconnect electricity, block moveable parts, release or block spring energy, release pressure from hydraulic and pneumatic lines, and lower suspended parts to a resting position.

5. **Test** - Do a complete test and personally double check all of the above steps to verify that all of the power sources are actually disconnected and locked out.

6. **Restore Power** - When the work has been completed, follow the same basic procedures, ensuring that all individuals working on or around this machine are safely clear of the machine before locks and tags are removed and power is restored.

IMPORTANT

It is important that everyone who works on this equipment is properly trained to help ensure that they are familiar with this procedure and that they follow the steps outlined above. This manual will remind you when to **Shutoff & Lockout Power**.

At times parts on this implement will become worn or damaged. Performing repairs on this implement can pose a risk of injury including death. To reduce risk, the party that will be doing the repair should be very knowledgeable of the implement and the equipment that they will be using to do the repair.

- Review the repair so that a plan can be put together and the proper equipment can be used to repair this implement safely and correctly.
- Personal safety equipment may include items such as safety glasses, protective footwear, hearing protection, gloves, fire retardant clothes, etc.



WARNING

Crushing Hazard

Do Not work under suspended or blocked parts.



- The use of hoists and/or supports may be needed to handle heavy components.
- If the implement is being repaired in the field, make sure the parking brake of the tractor is engaged, the implement is on solid and level ground.

Welding and torching should be done by properly trained individuals who have proven their skills.

IMPORTANT

Call the factory for any additional details you may need to perform the repair. Some parts may come with instruction sheets to assist in the repair. Instructions sheets may be provided with your parts order. Otherwise, if available, instruction sheets can be e-mailed or faxed for you convenience. Call Meyer Manufacturing Corporation toll free at 1-800-325-9103 or email sales@meyermfg.com.

IMPORTANT

The standard forage box header unit discharges to the LH side and the parts illustrations depict these units. If you have an optional RH unit, always specify the part number shown in this book followed by -RH. Nearly all header parts appear similar to the standard unit but are really mirror images. Box parts are all identical. If you specify -RH and there is no difference in the item you wish to order, this will be properly interpreted at the factory and will not cause any problem.

NOTE: Be environmentally friendly and dispose of any waste materials properly. Recycle when appropriate.



9.0 SPECIFICATIONS

9.1 RT SPECIFICATIONS

Front Unload	RT616	RT618	RT620	RT622
DIMENSIONS				
Floor Length	16'6"	18'6"	20'6"	22'6"
Overall Length	19'8"	21'8"	23'8"	25'8"
Inside Height (without roof)	std height	6'3"	6'3"	6'3"
	high sides	7'3"	7'3"	7'3"
Overall Height (without roof)				
top of side	std height	94"	94"	94"
	high sides	106"	106"	106"
Less 4" truck & trailer mounts (except on XT1600 trailer*)	*	*	*	
Overall Height (with roof) - wagon mount version	std height	114.5"	114.5"	114.5"
	high sides	126.5"	126.5"	126.5"
Inside Width	89.5"	89.5"	89.5"	89.5"
Overall Width with conveyor extension up	109.5"	109.5"	109.5"	109.5"
Stringer Width/Height				
truck/XT2200 trailer mount	33.5"/6"	33.5"/6"	33.5"/6"	33.5"/6"
wagon mount	42"/10"	42"/10"	42"/10"	42"/10"
Capacity (struck level) cu. ft. (without roof)	(6'3") std height	769	862	956
	(7'3") high sides	892	1000	1108
Capacity cu. ft. (with roof)	(6'3") std height	944	1058	1174
	(7'3") high sides	1067	1196	1326
SPECIFICATIONS				
Front Apron Drive Shaft	2"	2"	2"	2"
Tubular Upright Spacing	24"	24"	24"	24"
All Steel Frame - 24" centers (no wood)	Std 24"	Std 24"	Std 24"	Std 24"
HD Tubular Floor Supports	2x2	2x2	2x2	2x2
HD Top Rail Formed (no side supports needed)	Std	Std	Std	Std
Commercial Grade Geardrive (no worm gears)	Std	Std	Std	Std

9.2 RTX SPECIFICATIONS

	Front Unload	RTX620	RTX622	RTX624	RTX626
DIMENSIONS					
Floor Length		20'6"	22'6"	24'6"	26'6"
Overall Length		23'8"	25'8"	27'8"	29'8"
Inside Height (without roof)	std height	-	-	-	-
	high sides	7'3"	7'3"	7'3"	7'3"
Overall Height (without roof)					
top of side	std height	-	-	-	-
	high sides	106"	106"	106"	106"
Less 4" truck & trailer mounts (except on XT1600 trailer*)		*	*	*	
Overall Height (with roof) - wagon mount version	std height	-	-	-	-
	high sides	126.5"	126.5"	126.5"	126.5"
Inside Width		89.5"	89.5"	89.5"	89.5"
Overall Width with conveyor extension up		109.5"	109.5"	109.5"	109.5"
Stringer Width/Height					
truck/XT2200 trailer mount		33.5"/6"	33.5"/6"	33.5"/6"	33.5"/6"
wagon mount		42"/10"	42"/10"	42"/10"	42"/10"
Capacity (struck level) cu. ft. (without roof)	(6'3") std height	-	-	-	-
	(7'3") high sides	1108	1217	1325	1433
Capacity cu. ft. (with roof)	(6'3") std height	-	-	-	-
	(7'3") high sides	1326	1456	1585	1714
SPECIFICATIONS					
Front Apron Drive Shaft		2"	2"	2"	2"
Tubular Upright Spacing		16"	16"	16"	16"
All Steel Frame - 24" centers (no wood)		Std 16"	Std 16"	Std 16"	Std 16"
HD Tubular Floor Supports		2x2	2x2	2x2	2x2
HD Top Rail Formed (no side supports needed)		Std	Std	Std	Std
Commercial Grade Geardrive (no worm gears)		Std	Std	Std	Std



Meyer Manufacturing Corporation

674 W. Business Cty Rd A

Dorchester, WI 54425

Phone: 1-800-325-9103

Fax: 715-654-5513

Email: parts@meyermfg.com

Website: www.meyermfg.com