



PB-SXIB



SXI

720 • 865

Owner / Operator's Manual & Parts Book

Pull Type: 2021 Model Year Only

Including Truck Mounts: Starting 2020 Model Year



MEYER
MFG. CORP.



PRODUCT
MANUALS

1.0 IMPORTANT INFORMATION

The serial number plate is located on the front left-hand side.

Please enter the model, serial number and additional information in the space provided for future reference.



Model No. _____

Spreader Body Serial No. _____

Date of Purchase _____

Dealership _____

Dealership Phone No. _____

Always use your serial number when requesting information or when ordering parts.

HOW TO READ YOUR SERIAL NUMBER

EXAMPLE: SXI21865201

Model Type / Model Year / Model / Sequence Of Build



SXI

21

865

201

Meyer Manufacturing Corporation
674 W. Business Cty Rd A
Dorchester, WI 54425
Phone: 1-800-325-9103
Fax: 715-654-5513
Email: parts@meyermfg.com
Website: www.meyermfg.com



2.0 PRE-DELIVERY & DELIVERY CHECK LIST

Spreader Check List

Meyer Manufacturing Corporation

Phone: 715-654-5132 • Toll-Free: 1-800-325-9103 • P.O. Box 405 • Dorchester, WI 54425

This Pre-Delivery & Delivery Check List must be gone through by the Selling Party and the Customer to validate the Owner's Registration Form.

PRE-DELIVERY CHECK LIST

After the new Meyer Spreader has been completely set-up, check to be certain it is in correct running order before delivering it to the customer.

The following is a list of points to inspect:

Check off each item as you have made the proper adjustments and found the item operating satisfactorily. Any adjustments made, MUST be according to specifications defined in this manual.

- All shields and guards are in place and securely fastened.
- All bolts and other fasteners are secure and tight.
- All mechanisms operate trouble free.
- All grease fittings have been lubricated, gear boxes filled to proper levels, and all roller chains are oiled. See "Lubrication" section of this manual.
- PTO shields turn freely.
- All roller chain and belt springs adjusted properly for automatic tensioning. See "Adjustments" section in this manual.
- All stop/tail/turn lights work properly.
- All decals are in place and legible.

DELIVERY CHECK LIST

The following check list is an important reminder of valuable information that MUST be passed on to the customer at the time the unit is delivered.

Check off each item as you explain it to the customer.

- Explain to the customer that pre-delivery check list was fully completed.
- Give customer the Owner & Operator's Manual. Instruct to read and completely understand its contents BEFORE attempting to operate the spreader.
- Explain and review with customer the new Meyer Spreader manufacturer's warranty.
- Show the customer where to find the serial number on the implement.
- Explain and review with the customer "Safety Precautions" section of this manual.
- Explain and review with customer the proper "Start-up and Operating Procedures" sections of this manual.
- Demonstrate the PTO Shaft Locking Device and proper PTO shaft storage. Also, demonstrate proper hydraulic hose storage and tip holder used to keep system clean from contaminants.
- Explain that regular lubrication and proper adjustments are required for continued proper operation and long life of the spreader. Review with the customer the "Lubrication" and "Adjustments" sections of this manual.
- Explain and review with customer the recommended loading and unloading procedures for different types of manure.
- Fully complete this "PRE-DELIVERY & DELIVERY CHECK LIST" with the customer.



3.0 INTRODUCTION

Congratulations on your purchase of a new Meyer farm equipment product. Undoubtedly you have given much consideration to your purchase and we're proud that you have selected Meyer. Pride in craftsmanship, engineering and customer service have made Meyer products the finest in the farm equipment industry today.

There is no substitute for quality. That is why thousands of people like you have purchased Meyer farm equipment. They felt it was the best equipment to serve their farming needs, now and in years to come. We ask that you follow our policy of "safety first", and we strongly suggest that you read through the "Owner / Operator's Manual & Parts Book" before operating your Meyer farm equipment. Meyer Manufacturing Corporation wants to thank you for not compromising quality. We are determined to offer excellence in customer service as well as provide you with the very best value for your dollar.

Sincerely,

*All Employees of
MEYER MANUFACTURING CORPORATION*

The SXI spreader is available as a truck mounted or pull-type unit pulled and powered by a farm tractor.

When the PTO is referred to, it means power take-off from the truck.

The SXI spreader may be referred to as 720, 865, SXI, spreader or implement in this manual.



IMPORTANT: You are urged to study this manual and follow the instructions carefully. Your efforts will be repaid in better operation and service as well as a savings in time and repair expense. Failure to read this manual and understand the machine could lead to serious injury. If you do not understand instructions in this manual, contact either your dealer or Meyer Manufacturing Corp. at Dorchester, WI 54425.



WARRANTY: At the front of this manual is an "Owner's Registration Form". Be sure your dealer has completed this form and promptly forwarded a copy to Meyer Manufacturing to validate the manufacturer's warranty. The product model and serial number are recorded on this form and on the inside of the front cover for proper identification of your Meyer SXI spreader by your dealer and the manufacturer when ordering repair parts. The serial number plate is located on the front left-hand side.

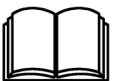

REPAIR PARTS: At the back of this manual is the repair parts section. All replacement parts are to be obtained from or ordered through your Meyer dealership. When ordering repair parts, refer to the parts section and give complete information including quantity, correct part number, detailed description and even model number and serial number of the SXI spreader which needs repair parts.

Manufacturer's Statement: Meyer Manufacturing Corporation reserves the right to make improvements in design, or changes in specifications at any time, without incurring any obligation to owners of units previously sold. This supersedes all previous published instructions.



TABLE OF CONTENTS

1.0	IMPORTANT INFORMATION	2
2.0	PRE-DELIVERY & DELIVERY CHECK LIST	3
3.0	INTRODUCTION	5
4.0	MANUFACTURER'S WARRANTY	11
5.0	SAFETY	13
5.1	SAFETY PRECAUTIONS	14
5.2	SAFETY SIGNS	16
5.3	SHUTOFF & LOCKOUT POWER	21
5.3.1	Shutoff & Lockout Power Recommendations	21
6.0	PRE-OPERATION	23
6.1	STATIC INSPECTION	23
6.2	LIGHT HOOK-UP	24
6.3	HYDRAULIC HOOK-UP	24
6.4	PTO DRIVELINE	24
6.5	TRACTOR DRAWBAR SETUP	25
6.6	HITCHING TO TRACTOR	26
6.7	START-UP AND SHUT-DOWN	26
6.7.1	Start-Up	26
6.7.2	Shut-Down	27
6.8	OPERATIONAL CHECKS	27
6.9	TRANSPORTING	28
6.9.1	Safety Chain	29
6.9.2	Tractor Towing Size Requirements	30
6.9.3	Spreader Brake Information (Optional)	30
6.9.3.1	Lever Operated Hydraulic Brakes	30
6.9.3.2	Pedal Operated Hydraulic Brakes	30
7.0	OPERATION	31
7.1	LOADING	31
7.2	UNLOADING	32
7.2.1	PTO Cutout Clutch	33
7.3	SHEAR SPROCKET	34

7.4	FREEZING WEATHER OPERATION	34
7.5	UNHOOKING THE TRACTOR	35
8.0	MAINTENANCE	37
8.1	LUBRICATION	37
8.1.1	Daily Lubrication (Every 8-12 Loads*)	38
8.1.2	Weekly Lubrication (Every 65-70 Loads*)	38
8.1.3	Monthly Lubrication (Every 260-300 Loads*)	40
8.1.4	Break-In Lubrication (First 360-500 Loads*)	40
8.1.5	Annual Lubrication	40
8.1.6	Automatic Chain Oiler	41
8.2	ADJUSTMENTS	42
8.2.1	Front Drive Roller Chains	42
8.2.2	Front Spinner Drive Belt	42
8.2.3	Balance of Spinners	42
8.2.4	PTO Cutout Clutch Connection	43
8.2.5	720 Brake Adjustment	43
8.2.6	865 Brake Adjustment	43
8.2.7	Wheel Bearing Preload	43
8.2.8	Truck Mount Die Spring	43
8.3	BRAKES (OPTIONAL)	44
8.3.1	720 Brake Bleeding	44
8.4	WHEELS AND TIRES	45
8.4.1	Wheel Installation	45
8.4.2	Wheel Torque	45
8.4.3	Tire Inflation	45
8.4.4	Implement Tires	45
8.5	STORING THE SPREADER	47
8.6	RETURNING THE SPREADER TO SERVICE	47
9.0	PARTS REPAIR AND REPLACEMENT	49
9.1	REPLACEMENT PARTS	49
	CUTOUT CLUTCH	51
	PTO DRIVE SHAFT	52
	FIRST REDUCTION AND SPINNER DRIVE	54
	BERMA FRONT GEARBOX	56
	SECOND REDUCTION DRIVE	58
	FINAL REDUCTION, RH AUGER DRIVE	60
	FINAL REDUCTION, LH AUGER & THIRD AUGER DRIVE	62
	BODY & SHIELDS	64

AUGERS	68
SPINNERS & GEARBOXES	70
CORNER GEARBOX	72
RIGHT SPINNER GEARBOX	74
LEFT SPINNER GEARBOX	76
SPINDLES & O-BEAMS	78
HUB ASSEMBLY	84
FRONT GREASE HOSES	86
O-BEAMS & REAR GREASE HOSES	87
REAR GATE	88
STANDARD HYDRAULICS	90
OIL-KIT	92
HIGHWAY LIGHTS	94
TRUCK MOUNT BODY & SHIELDS	96
TRUCK MOUNT FRONT DRIVE	98
TRUCK MOUNT UPPER GEARBOX	100
TRUCK MOUNT LOWER GEARBOX	102
TRUCK MOUNT CUT-OUT CLUTCH	104
10.0 OPTIONAL EQUIPMENT	105
WEIGH BAR WIRING DIAGRAM (720 ONLY)	106
HYDRAULIC DRIVEN AUGER DRIVE COMPONENTS	108
HYDRAULIC DRIVEN AUGER BODY & SHIELDS	110
HYDRAULIC DRIVEN AUGER HYDRAULIC SCHEMATIC	112
HYDRAULIC DRIVEN AUGER FRONT HOSES	113
720 BRAKE COMPONENTS	114
720 FOOT CONTROL BRAKE SCHEMATIC	116
865 FOOT CONTROL BRAKE SCHEMATIC	118
865 HAND LEVER CONTROL BRAKE SCHEMATIC	120
11.0 SPECIFICATIONS	123
MAINTENANCE RECORD	127



4.0 MANUFACTURER'S WARRANTY

11/2014

MEYER SXI Spreader

- I. The "Owner's Registration Form" must be completed in full and promptly returned to Meyer Mfg. Corp. for this warranty to become both valid and effective. All warranties on new Meyer SXI Spreaders shall apply only to the original retail customer from an authorized Meyer Mfg. Corp. dealership.
- II. This warranty shall not apply to any Meyer SXI Spreader which has been subjected to misuse, negligence, alteration, accident, incorrect operating procedures, has been used for an application not designed for or preauthorized by Meyer in writing, has had the serial numbers altered, or which shall have been repaired with parts other than those obtained through Meyer Mfg. Corp. Meyer is not responsible for the following: Depreciation or damage caused by normal wear, lack of reasonable and proper maintenance, failure to follow the operator's manual recommendations or normal maintenance parts and service. Meyer is not responsible for rental of replacement equipment during warranty repairs, damage to a power unit (including but not limited to a truck or tractor), loss of earnings due to equipment down time, or damage to equipment while in transit to or from the factory or dealer.
- III. Meyer Mfg. Corp. warrants new Meyer SXI Spreaders to be free from defects in material and workmanship under recommended use and maintenance service, as stated in the "Owner / Operator's Manual & Parts Book" as follows:
 - A. Meyer Mfg. Corp. will repair or replace F.O.B. Dorchester, WI, as Meyer Mfg. Corp. elects, any part of a new SXI Spreader which is defective in material or workmanship:
 - i. Without charge for either parts or labor during the first (1) year from purchase date to the original retail customer.
 - B. In addition to the above basic warranty, Meyer Mfg. Corp. will repair or replace F.O.B. Dorchester, WI as Meyer Mfg. Corp. elects:
 - i. Any part of the following which is defective in material or workmanship (not neglect to recommended use and service) with a "pro-rated" charge for parts only (not labor) during the stated time period from date of purchase to the original retail customer:

Seven (7) Years:

 - a. The spreader tank body is warranted against rust through (Pro-rated parts only). Parts included, front and rear end panels, side panels and auger trough.
- IV. COMMERCIAL USE: Coverage as in paragraph III.A.i. ONLY, except warranty coverage is for (90) days for parts and labor to the original commercial retail customer.
- V. Repairs eligible for labor warranty must be made by Meyer Mfg. Corp. or an authorized Meyer dealership. The original retail customer is responsible for any service call and/or transportation of the SXI Spreader to the dealership or factory for warranty service.
- VI. Except as stated above, Meyer Mfg. Corp. shall not be liable for injuries or damages of any kind or nature, direct, consequential, or contingent, to persons or property. This warranty does not extend to loss of crop or for any other reasons.
- VII. No person is authorized to give any other warranties or to assume any other obligation on Meyer Mfg. Corp.'s behalf unless made or assumed in writing by Meyer Mfg. Corp. This warranty is the sole and exclusive warranty which is applicable in connection with the manufacture and sale of this product and Meyer Mfg. Corp.'s responsibility is limited accordingly.

Purchased Product Warranty:

This warranty does not apply to component parts not manufactured by Meyer such as but not limited to wheels, tires, tubes, PTO shafts, clutches, hydraulic cylinders, scales, tarps, etc.



5.0 SAFETY

The Meyer SXI Spreader is manufactured with operator safety in mind. Located on the spreader are various safety signs to aid in operation and warn of danger or caution areas. Pay close attention to all safety signs on the spreader.

Carefully follow the operating and maintenance instructions in this manual and all applicable safety laws. Failure to follow all safety procedures may result in serious injury or death.

Before attempting to operate this spreader, read and study the following safety information. In addition, make sure that every individual who operates or works with the spreader, whether family member or employee, is familiar with these safety precautions.

Meyer Mfg. Corp. provides guards for exposed moving parts for the operator's protection; however, some areas cannot be guarded or shielded in order to assure proper operation. The operator's manual and safety signs on the spreader itself warn you of dangers and must be read and observed closely!



Safety Alert Symbol

This symbol is used to call attention to instructions concerning personal safety. Be sure to observe and follow these instructions. Take time to be careful!



DANGER

The signal word **DANGER** on the machine and in the manual identifies a hazardous situation which, if not avoided, WILL result in death or serious injury.



WARNING

The signal word **WARNING** on the machine and in the manual indicates a potentially hazardous situation which, if not avoided, COULD result in death or serious injury.



CAUTION

The signal word **CAUTION** on the machine and in the manual indicates a potentially hazardous situation which, if not avoided, MAY result in minor or moderate injury. It may also be used to alert against unsafe practices.

IMPORTANT

This notice identifies procedures which must be followed to avoid damage to the machine.

Danger, Warning, Caution, and instructional decals and plates are placed on the equipment to protect anyone working on or around this machine, as well as the components of the machine. All personnel operating or maintaining this equipment must familiarize themselves with all Danger, Warning, Caution, and instructional decals and plates.

5.1 SAFETY PRECAUTIONS



All individuals who will operate this spreader must read and completely understand this Owner / Operator's And Parts Manual. Operator must receive instructions before operating the machine. Untrained operators can cause injury or death.

- DO NOT allow anyone to operate, service, inspect or otherwise handle this spreader until all operators have read and understand all of the instructional materials in this Owner / Operator's And Parts Manual and have been properly trained in its intended usage.
- For an operator to be qualified, he or she must not use drugs or alcohol which impair alertness or coordination while working. An operator who is taking prescription drugs must get medical advice to determine if he or she can safely operate a machine and the equipment.
- Make sure all personnel can READ and UNDERSTAND all safety signs.
- DO NOT allow minors (children) or inexperienced persons to operate this spreader.
- DO NOT operate until all shields and guards are in place and securely fastened.
- DO NOT step up on any part of the spreader at any time.
- DO NOT adjust, clean or lubricate while the spreader is in motion.
- Inspect when first delivered and regularly thereafter; that all connections and bolts are tight and secure before operating.
- Know how to stop operation of the spreader before starting it!
- Make certain everyone is clear of the spreader before applying power.
- Keep hands, feet and clothing away from moving parts. Loose or floppy clothing should not be worn by the operator.
- Observe all applicable traffic laws when transporting on public roadways (where legal to do so). Check local laws for all highway lighting and marking requirements.
- Shut off and lock out power before adjusting, servicing, maintaining or clearing an obstruction from this machine. (See 5.3 SHUTOFF & LOCKOUT POWER on page 21.)
- Always enter curves or drive up or down hills at a low speed and at a gradual steering angle.
- Never allow riders on either tractor / truck or equipment.
- Keep tractor / truck in a lower gear at all times when traveling down steep grades.
- Maintain proper brake settings at all times (if equipped).
- Stay well clear of the spreader's rear discharge spinners while operating.
- Do not step over the power take-off shaft. Stay clear of PTO at all times.
- Use only properly rated tires.
- **When towing the spreader on public roads**, a safety chain of sufficient strength to support the gross weight of the spreader must be used. (See Maximum Load Weight Chart in the Transporting Section). The safety chain should be attached per diagram in the Transporting Section.

Safety Precautions For Tractor Towed Units:

- Do not exceed 20 mph (32 kph). Reduce speed on rough roads and surfaces.
- Always install a SMV emblem on pull-type equipment when transporting on roadways and keep clean and bright.
- Always yield to oncoming traffic in all situations and move to the side of the road so any following traffic may pass.
- Comply with state and local laws governing highway safety and movement of machinery on roadways.

Safety Precautions For Hydraulic System:

- Check hydraulic tubes, hoses and fittings for damage and leakage. Never use hands to check for leaks. Hydraulic tubes and hoses must be properly routed and have adequate support and secure clamps. Tighten or replace any parts that show leakage.
- Always clean fluid spills. Do not use gasoline or diesel fuel for cleaning parts. Use commercial nonflammable solvents.

5.2 SAFETY SIGNS



Read all safety signs on the spreader and in this manual. Keep all safety signs clean and replace any damaged or missing safety signs before operating the equipment. Do not remove any safety signs. Safety signs are for operator protection and information.

FRONT OF SPREADER

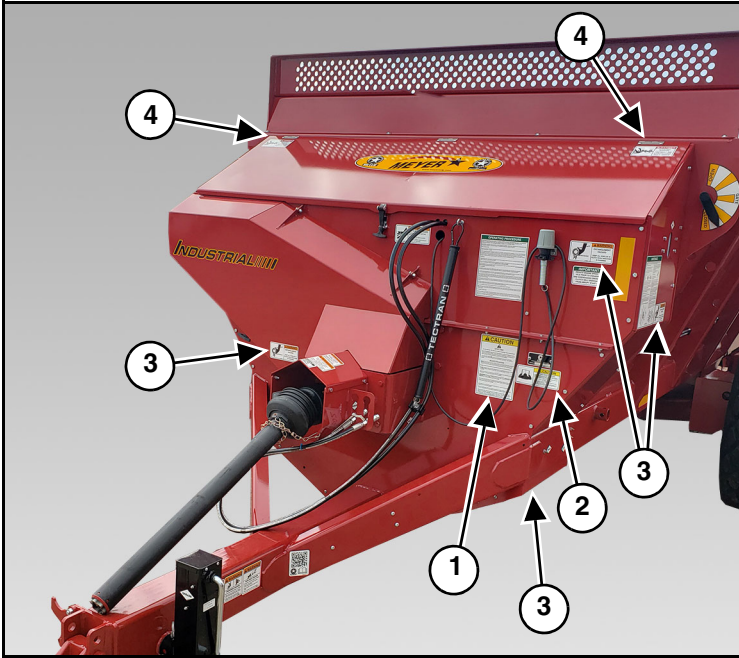

1

! CAUTION

SAFETY FIRST

Do Not Operate This Machine Without Reading These Instructions!

Meyer Manufacturing Corporation provides guards for exposed moving parts for the operator's protection; however, some areas cannot be guarded or shielded in order to ensure proper operation. The operator's manual and safety signs on the equipment itself warn you of hazards and must be read and observed closely!

The safety alert symbol is used to call attention to instructions concerning personal safety. Be sure to observe and follow these instructions. Take time to be careful!

! SAFETY PRECAUTIONS

DO NOT allow anyone to operate, service, inspect or otherwise handle this equipment until all operators have read and understood all of the instructional materials in the operator's and parts manual and have been properly trained in its intended usage.

DO NOT operate until all shields and guards are in place and securely fastened.

DO NOT step up on any part of the equipment that is not designated as a seat, ladder, or viewing platform at any time. Never allow riders on either tractor / truck or equipment.

Ensure the machine is and will remain in the OFF condition before adjusting, servicing, maintaining, or clearing an obstruction from this machine.

PTO OPTIONS: The tractor PTO **MUST** match the implement PTO. **NEVER USE PTO ADAPTERS.** PTO shield **MUST** be in place and rotate freely. Always run PTO in a straight line to avoid an accident due to PTO damage.

Know how to stop operation of the equipment before starting it! Make certain everyone is clear of the equipment before applying power. Make certain everyone stays clear of the discharge opening while operating.

Keep hands, feet, and clothing away from moving parts. Loose or floppy clothing should not be worn by the operator.

Observe all applicable traffic laws when transporting on public roadways (where legal to do so). Check local laws for all highway lighting and marking requirements.

Keep all safety signs clean and replace any damaged or missing safety signs before operating the equipment. **DO NOT** remove any safety signs. If any safety signs become damaged or lost, call your local Meyer dealer or Meyer factory direct 1-800-325-9103 for replacement. Always use **GENUINE MEYER** replacement parts.

46-0001-22 1

PART NO. 46-0001-22

3

! WARNING

ENTANGLEMENT HAZARD

KEEP ALL SHIELDS IN PLACE WHILE MACHINE IS RUNNING

46-0001-4 1

PART NO. 46-0001-4

2

! CAUTION

TO PREVENT SERIOUS INJURY OR DEATH

- **DO NOT** start, operate, or work on this machine without first carefully reading and thoroughly understanding the entire contents of the operator's manual. (Require the same of all personnel who will operate this machine.)
- If operator's manual is lost, contact your nearest Meyer Dealership or write or call:

MEYER MFG., CORP.
P.O. BOX 405 • Dorchester, WI 54425-0405
Phone 1-800-325-9103

Please give your name, address, phone number, model and serial number of your machine. A manual will be furnished.

- If you have any questions about operation or adjustments, and maintenance of this machine, contact your Meyer Dealership or Meyer Mfg., Corp. before starting or continuing the operation of this machine.

46-0001-35 1

PART NO. 46-0001-35

4

! DANGER

ROTATING AUGERS

DISCONNECT AND LOCK OUT POWER BEFORE ENTERING BOX TO SERVICE

46-0001-5 1

PART NO. 46-0001-5

FRONT OF SPREADER

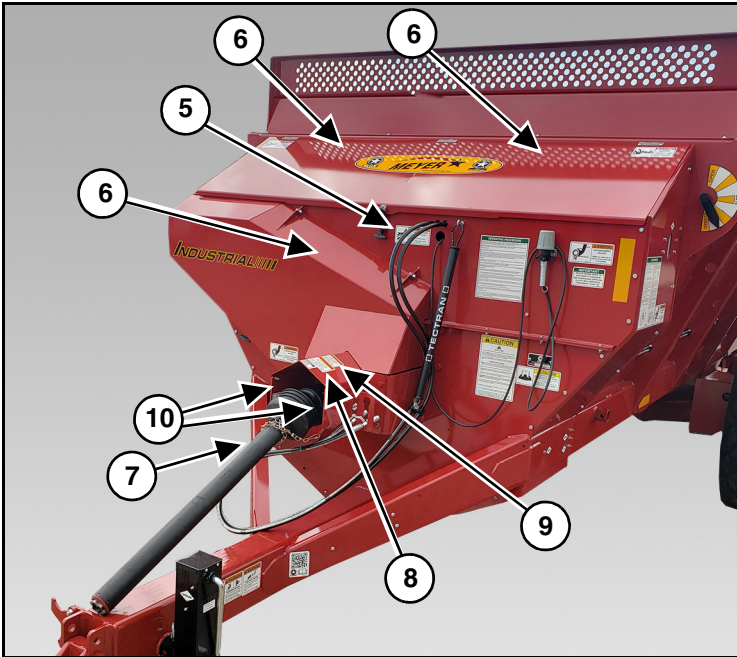

5

	⚠ WARNING
	OIL INJECTION HAZARD
	RELIEVE PRESSURE BEFORE SERVICING.
	DO NOT CHECK WITH HANDS. IF INJURED SEEK EMERGENCY MEDICAL ATTENTION.

46-8500-7 1

PART NO. 46-8500-7

6

	⚠ DANGER
	ENTANGLEMENT HAZARD
	SHIELD IS OFF. CLOSE OR REPLACE SHIELD BEFORE OPERATING.

46-0001-26 1

PART NO. 46-0001-26
(Located Under Shield)

8

	⚠ WARNING
	NOT A STEP!
	This is a PTO Guard. Very serious injury or amputation could result from contact with rotating PTO shaft.

46-0004-2 1

PART NO. 46-0004-2

9

	⚠ WARNING
	ROTATING DRIVE LINE CAN CRUSH AND DISMEMBER
	DO NOT OPERATE WITHOUT SHIELD IN PLACE
	DISCONNECT AND LOCKOUT POWER SOURCE BEFORE ADJUSTING OR SERVICING UNIT.
	FAILURE TO HEED WILL RESULT IN DEATH OR PERSONAL INJURY

46-3600-9 1

PART NO. 46-3600-9

10

	⚠ DANGER
	SHIELD IS OFF
	ROTATING DRIVELINE REPLACE SHIELD BEFORE OPERATING

46-3600-2 1

PART NO. 46-3600-2
(Located Under Shield)

7

⚠ DANGER	
	
ROTATING DRIVE SHAFT	
CONTACT CAN CAUSE DEATH	
KEEP AWAY!	
DO NOT OPERATE WITHOUT-	
<ul style="list-style-type: none"> • ALL DRIVE SHAFT GUARDS, TRACTOR AND EQUIPMENT SHIELDS IN PLACE • DRIVE SHAFT SECURELY ATTACHED AT BOTH ENDS • DRIVE SHAFT GUARDS THAT TURN FREELY ON DRIVE SHAFT • READ OPERATOR'S MANUAL 	
DO NOT USE PTO ADAPTORS	

LEFT SIDE OF SPREADER

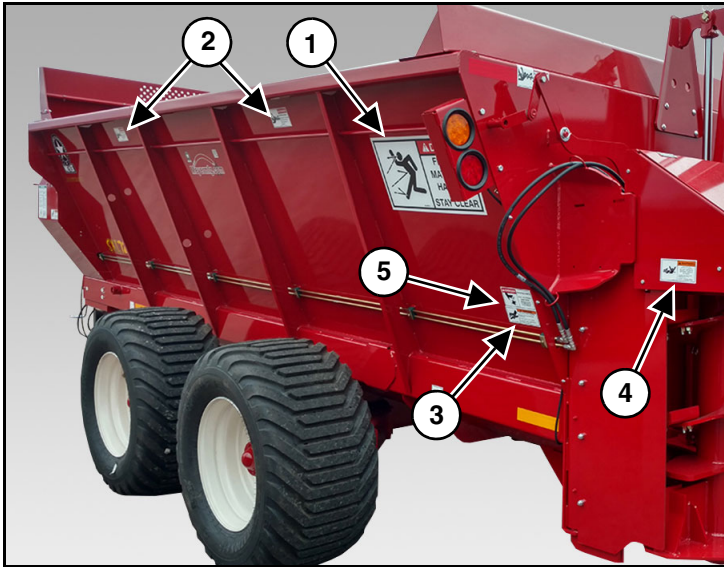

PART NO. 46-8865-4



PART NO. 46-0001-5



PART NO. 46-8500-7



PART NO. 46-9500-4



PART NO. 46-3600-9



PART NO. 46-0001-4

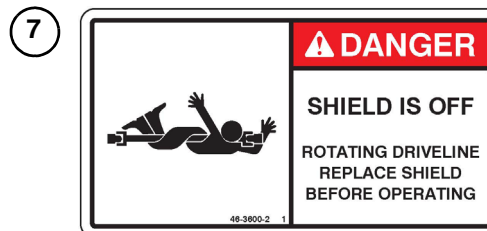

PART NO. 46-3600-2
(Located Under Shield)

RIGHT SIDE OF SPREADER

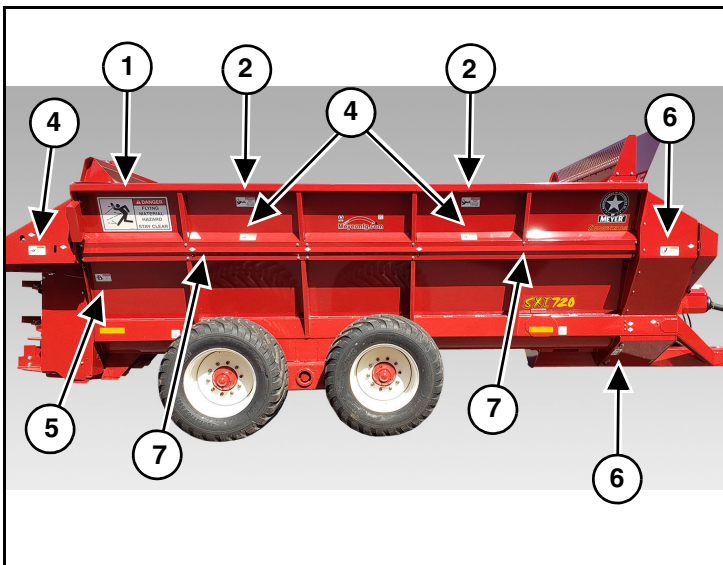

REAR OF SPREADER

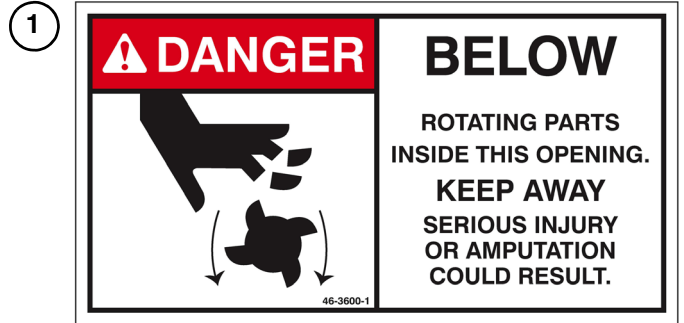
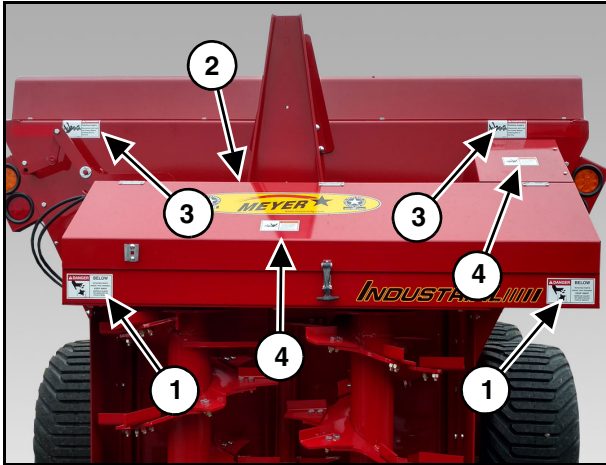

PART NO. 46-3600-1



PART NO. 46-3600-2
(Located Under Shield)

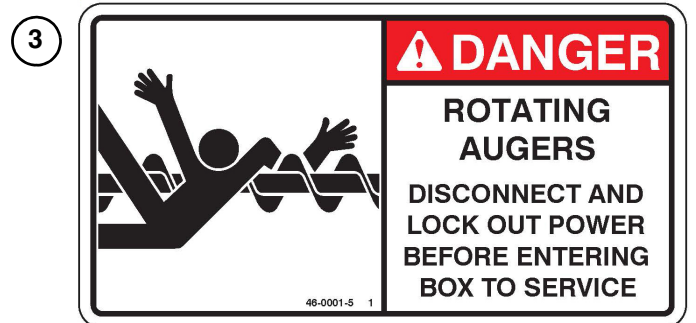

PART NO. 46-0001-5



PART NO. 46-3600-9

FRONT HITCH OF SPREADER

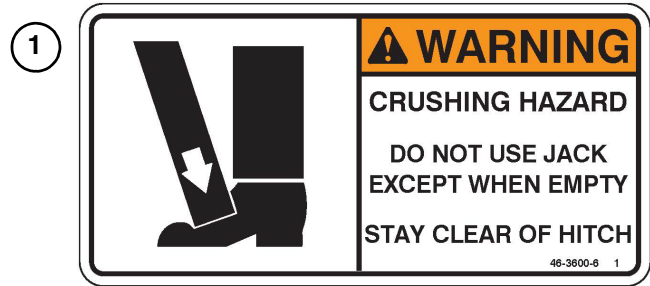
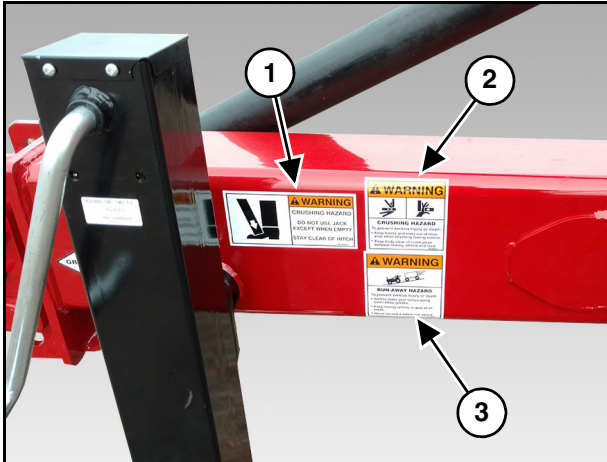

PART NO. 46-3600-6



PART NO. 46-0800-6



PART NO. 46-0800-7

5.3 SHUTOFF & LOCKOUT POWER



CAUTION

Any individual that will be adjusting, servicing, maintaining, or clearing an obstruction from this machine needs to ensure that this machine stays safely “OFF” until the adjustment, service, or maintenance has been completed, or when the obstruction has been cleared, and that all guards, shields, and covers have been restored to their original position. The safety of all individuals working on or around this machine, including family members, are affected. The following procedure will be referred to throughout this manual, so be familiar with the following steps.

5.3.1 Shutoff & Lockout Power Recommendations

1. Think, Plan and Check

- a. **Think** through the entire procedure and identify all the steps that are required.
- b. **Plan** what personnel will be involved, what needs to be shut down, what guards / shields need to be removed, and how the equipment will be restarted.
- c. **Check** the machine over to verify all power sources and stored energy have been identified including engines, hydraulic and pneumatic systems, springs and accumulators, and suspended loads.

2. **Communicate** - Let everyone involved, including those working on or around this machine, that work is being done which involves keeping this machine safely “OFF”.

3. Power Sources

- a. **LOCKOUT** - Shut off engines and take the key, or physically lock the start/on switch or control. Disconnect any power sources which are meant to be disconnected (i.e. electrical, hydraulic, and PTO of pull-type units).
- b. **TAGOUT** - Place a tag on the machine noting the reason for the power source being tagged out and what work is being done. This is particularly important if the power source is not within your sight and/or will need to be isolated for a longer period of time.

4. **Stored Energy** - Neutralize all stored energy from its power source. Ensure that this machine is level, set the parking brake, and chock the wheels. Disconnect electricity, block moveable parts, release or block spring energy, release pressure from hydraulic and pneumatic lines, and lower suspended parts to a resting position.

5. **Test** - Do a complete test and personally double check all of the above steps to verify that all of the power sources are actually disconnected and locked out.

6. **Restore Power** - When the work has been completed, follow the same basic procedures, ensuring that all individuals working on or around this machine are safely clear of the machine before locks and tags are removed and power is restored.

IMPORTANT

It is important that everyone who works on this equipment is properly trained to help ensure that they are familiar with this procedure and that they follow the steps outlined above. **THIS MANUAL WILL REMIND YOU WHEN TO SHUTOFF & LOCKOUT POWER.**



6.0 PRE-OPERATION



CAUTION

DO NOT allow anyone to operate, service, inspect or otherwise handle this spreader until all operators have read and understand all of the instructional materials in this Owner / Operator's and Parts Manual and have been properly trained in its intended usage.

Verify that the spreader is securely fastened to the tractor / truck.

Verify that all electrical / hydraulic connections and bolts / hardware are tight and securely fastened before operating the spreader.

Always keep all shields and guards in place and securely fastened.

Keep hands, feet and clothing away.

Wear safety glasses to prevent eye injury when any of the following conditions exist:

- **When fluids are under pressure.**
- **Flying debris or loose material is present.**
- **Tools are being used.**

6.1 STATIC INSPECTION



WARNING

Hydraulic fluid escaping under pressure can have sufficient force to cause injury. Keep all hoses and connections in good serviceable condition. Failure to heed may result in serious personal injury or death.

Before operating the spreader for the first time and each time thereafter, check the following items:

1. Check that all safety signs are in good and legible condition.
2. Inspect the spreader for proper adjustments. (See 8.2 ADJUSTMENTS)
3. Lubricate the equipment. (See 8.1 LUBRICATION)
4. Make sure that all guards and shields are in place, secured and functioning as designed.
5. Check condition of all hydraulic components for leaks. Repair or replace as required.
6. Check the hydraulic and gear box oil level. (See 8.1 LUBRICATION)
7. Remove any twine, wire or other material that has become entangled around the rear spinners and augers.
8. Check to see that no obstructions are present in the spreader. Be sure that there are no tools laying on or in the spreader.
9. Verify that all electrical and hydraulic connections are tight and secure before operating.
10. Check that all hardware is in place and is tight.
11. Watch for any worn or cracked welds. If found, have qualified personnel repair immediately or replacement is necessary.
12. Check all bearings for wear. Replace as needed.
13. Some parts will wear due to use. It is highly recommended to replace critical safety items such as a hitch that has worn through the "Wear Plate" or is less than three quarters of its original thickness.
14. Inspect the tires for excessive wear or damage and inflate to the recommended pressure. (See 8.4 WHEELS AND TIRES)
15. Inspect the condition of axles, o-beams, spindles, and safety lighting. Repair or replace as required.
16. Check that the brakes are clean and clean them if necessary. (Brake Option Only) See 8.3 BRAKES (Optional).
17. Inspect the condition of the spinner drive belts. Replace if broken or damaged.

6.2 LIGHT HOOK-UP

Truck Mounted Models: A 4 pin electrical socket (Not Shown) is provided to connect the electrical control plug from your truck. This will operate signal, tail, clearance and brake lights.

NOTE: Depending on make and model of the truck, it may be necessary to install a light converter. (Meyer part #56-0028). The converter allows signal lights and brake lights to operate according to DOT Lighting Standards.

6.3 HYDRAULIC HOOK-UP



Hydraulic fluid escaping under pressure can have sufficient force to cause injury. Keep all hoses and connections in good serviceable condition. Failure to heed may result in serious personal injury or death.

Whenever working on any part of the hydraulics, safely relieve hydraulic pressure before starting.

NOTE: The PTO horsepower and/or hydraulic requirements may not reflect adequate tractor size for towing the machine.

6.4 PTO DRIVELINE



Shutoff and lockout power before performing machine service, adjusting, maintaining, or clearing an obstruction from this machine. Refer to section See 5.3 SHUTOFF & LOCKOUT POWER.



Do not operate without PTO guard on implement and tractor. Maintain PTO drive shaft guard tubes in good operating condition. Replace them if damaged and not turning freely. Failure to heed may result in serious personal injury or death.

The tractor half of the PTO drive shaft assembly must be locked securely to the tractor output shaft and the implement half of the PTO drive shaft assembly must be locked securely to the SXI driveline.

See your PTO Installation, Service, and Safety Instruction Manual for additional PTO details. For a replacement manual, call the factory at 1-800-325-9103.

See your ADMA Safety Manual for further safety situations and precautions that you should familiarize yourself and those that may be operating this equipment. For a replacement manual, call the factory at 1-800-325-9103.

IMPORTANT

DO NOT EXCEED THE MAXIMUM 80° TURNING ANGLE ON THE CONSTANT VELOCITY PTO DRIVELINE. EXCEEDING THE TURNING ANGLE WILL DAMAGE THE CONSTANT VELOCITY “CENTER HOUSING” AND WILL EXERT EXCESSIVE PRESSURES ON THE PTO INPUT CENTER SHAFT AND RELATED BEARINGS.

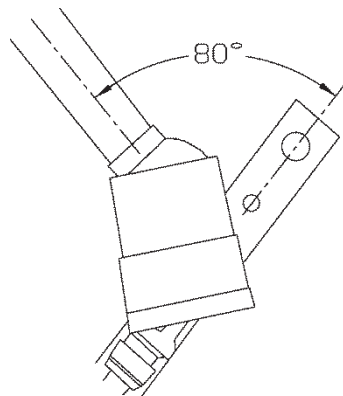

6.5 TRACTOR DRAWBAR SETUP

This spreader is to be operated with 1000 RPM PTO ONLY. No PTO adapter may be used to alter speed or geometry.

Set your tractor drawbar to conform to the standard dimensions as shown, Figure 1. This will ensure that the PTO drive shaft will not be over extended.

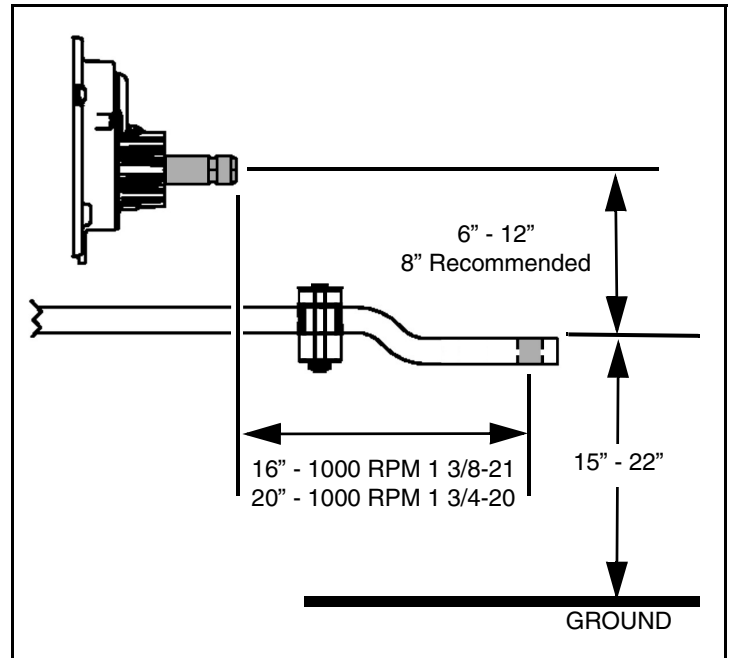

FIGURE 1. TRACTOR DRAWBAR & PTO SPECIFICATION

An improperly positioned hitch point may cause damage to the universal joints of the PTO drive shaft. Conforming to the standard 16" or 20" drawbar & PTO relationship will ensure that the PTO drive shaft will not become over-extended.

WITH INITIAL HOOK-UP TO YOUR NEW MEYER SPREADER TEST PTO TRAVEL BY TURNING EQUIPMENT IN BOTH DIRECTIONS OBSERVING THE MINIMUM (A) AND MAXIMUM (B) TRAVEL DIMENSIONS AS SHOWN, FIGURE 2.

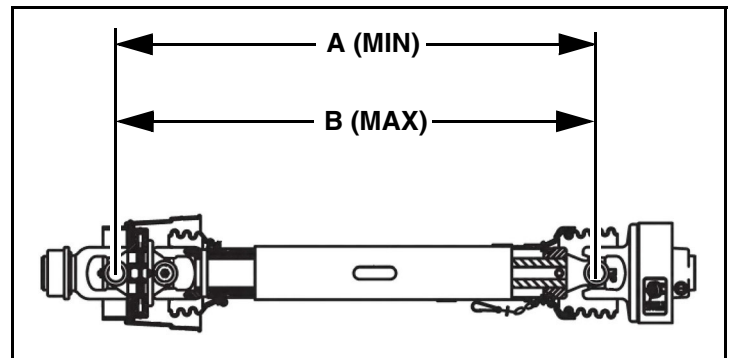

FIGURE 2. PTO DRIVELINE

PTO PART NUMBER	A	B
918-0511	50.00	68.70
918-0512	50.00	68.70

6.6 HITCHING TO TRACTOR

Move to the operator's position, start the engine and release the parking brake.



Do not allow anyone to stand between the tongue or hitch and the tractor when backing up to the spreader.

Move the tractor in front of the spreader. Slowly move the tractor backwards towards the spreader and align the drawbar with the implement's hitch.

NOTE: Lower or raise the spreader jack to properly align the drawbar and hitch.

Fasten the spreader hitch to the tractor drawbar with a properly sized hitch pin with safety retainer. (Reference ANSI/ASABE AD6489-3 Agricultural vehicles - Mechanical connections between towed and towing vehicles - Part 3: Tractor drawbar.) (See your Trailer / Chassis manual for further details.)

Before operation and after hitching the tractor to the implement, connect the hydraulic hoses, light cord and PTO drive shaft to the tractor. Slide the spring loaded locking collar onto the PTO yoke rearward, and then slide the yoke onto the tractor PTO shaft. Release the spring loaded collar. Be sure the pins fall into the groove of the tractor PTO shaft and that the collar snaps forward into the locked position. Move the tractor hydraulic controls to observe proper gate operation. Connect any optional equipment as needed.

NOTE: If the controls operate the rear gate in the opposite direction to what you expect, reverse the hydraulic hose connections at the tractor.

Remove the weight from the jack (jack is not to be used when spreader is loaded). Remove the jack from mount tube and move to the transport storage tube on the front of the spreader drive enclosure. Store in a horizontal position.

6.7 START-UP AND SHUT-DOWN



DO NOT allow anyone to operate, service, inspect or otherwise handle this spreader until all operators have read and understand all of the instructional materials in this Owner / Operator's And Parts Manual and have been properly trained in its intended usage.

Before operating the spreader, look in all directions and make sure no bystanders, especially small children are in the work area.



Disengage the hydraulic power, engage the machine's parking brake, stop the engine and make sure all moving components are completely stopped before connecting, disconnecting, adjusting or cleaning this equipment.

Always keep all shields and guards in place and securely fastened.

Keep hands, feet and clothing away.

6.7.1 Start-Up

Enter the tractor or truck and start the engine.

Slowly engage the PTO and operate at idle speed.

6.7.2 Shut-Down

Disengage the PTO.

Park the tractor / truck on a flat, level surface.

Engage the parking brake, stop the engine and exit the tractor or truck.

6.8 OPERATIONAL CHECKS



CAUTION

Shutoff and lockout power before performing machine service, adjusting, maintaining, or clearing an obstruction from this machine. Refer to section See 5.3 SHUTOFF & LOCKOUT POWER.

DO NOT allow anyone to operate, service, inspect or otherwise handle this spreader until all operators have read and understand all of the instructional materials in this Operator's And Parts Manual and have been properly trained in its intended usage.

Before operating the spreader, look in all directions and make sure no bystanders, especially small children are in the work area.



WARNING

Always keep all shields and guards in place and securely fastened. Keep hands, feet and clothing away.



DANGER

Make certain all personnel are clear of the spreader and the rotating spinners or beaters before applying power. Failure to heed may result in serious personal injury or death.

Before running material through the spreader for the first time and each time thereafter, follow the steps listed below.

1. Make sure spreader is empty.
2. Follow the Start-Up procedure section See 6.7.1 Start-Up.
3. Raise and lower the gate a couple times.
4. Operate the spreader for approximately 5-10 minutes.
5. Follow the Shut-Down procedure section See 6.7.2 Shut-Down.
6. Check drive components to be sure components are not abnormally hot.
7. Check all hydraulic components for leaks.
8. Adjust and lubricate equipment as needed. (See 8.1 LUBRICATION) & (See 8.2 ADJUSTMENTS).

NOTE: Check chain oiler reservoir oil level.

6.9 TRANSPORTING

CAUTION

AVOID SERIOUS INJURY OR DEATH

- Read and understand owner's manual before using. Review safety precautions annually.
- Before operating the spreader, look in all directions and make sure no bystanders, especially small children are in the work area.
- No riders allowed when transporting.
- Do not drink and drive.
- Before moving, be sure required lights and reflectors are installed and working.
- Before maintenance or repair, stop vehicle, set parking brake, and remove ignition key.
- Place safety stands under frame and chock wheels before working on tires or chassis.
- Maintain wheel bolts at torque as recommended in the manual.
- If equipped with brakes, maintain proper adjustment.

CAUTION

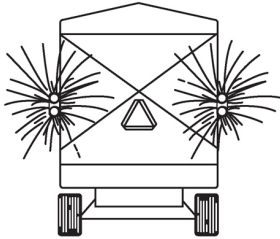

Pull-Type Units

- Use flashing warning lights when transporting on ALL highways (public roadways) at ALL times (Tractor towed models) EXCEPT WHEN PROHIBITED BY LAW! (Check w/local law enforcement).
- By all state and federal laws, implement lights do not replace the SMV (Slow-Moving Vehicle) identification emblem. All towed agricultural vehicles must display SMV emblems when traveling LESS than 20 mph (32 kph).
- Check for traffic constantly. Be sure you can see that no one is attempting to pass you and that all traffic is sufficiently clear from you before making any turns.
- Securely attach to towing unit. Use a high strength appropriately sized hitch pin with mechanical retainer and attach safety chain.
- Do not exceed 20 mph (32 kph). Slow down for corners and rough terrain.

WARNING



To Prevent Serious Injury Or Death

- Keeps hands and body out of the hitch area when attaching towing vehicle.
- Keep body clear of crush point between towing vehicle and load.

WARNING

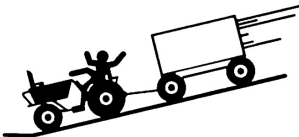

To Prevent Serious Injury Or Death

- Shift to lower gear before going down steep grades.
- Avoid traveling on slopes or hills that are unsafe.
- Keep towing vehicle in gear at all times.
- Never exceed a safe travel speed (which may be less than 20 MPH.)

WARNING

You must observe all applicable traffic laws when transporting on public roadways. Check local laws for all highway lighting and marking requirements. Failure to heed may result in serious personal injury or death.

WARNING

(Tractor Powered) Do not tow at speeds in excess of 20 mph. Failure to heed may result in serious personal injury or death.

IMPORTANT

Verify that the rear discharge door is in the closed position before traveling on roadways.

IMPORTANT

If you will travel on public roads and it is legal to do so, you must know all rules governing such operation. This will include lighting and brake requirements in addition to traffic rules.

NOTE: An optional highway lighting package is available to assist in meeting these requirements. See your Meyer dealer for details.

6.9.1 Safety Chain

WARNING

A safety chain must be installed to retain the connection between the tractor (or other towing vehicle) and implement whenever traveling on public roads in case the hitch connection would separate.

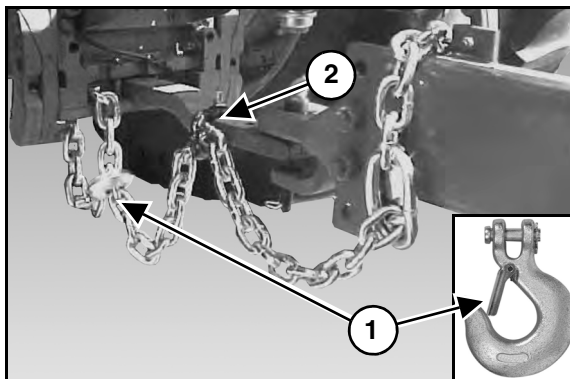

The chain must be of adequate size to hold the weight of the loaded spreader.

NOTE: If using a grab hook at the end(s) of the chain to secure the chain to itself, a hook latch (Item 1) must be installed.

The length of the safety chain is not to be any longer than necessary to turn without interference. If any chain links or attachment hardware are broken or stretched, repair before using. Store chain so it does not corrode or become damaged. Do not use this chain for other implements because the strength and length of the chain may not be adequate. Identify this chain for use on this particular spreader.

NOTE: Do not use the intermediate support (Item 2) as the attaching point.

IMPORTANT

If you do not have a safety chain, or a replacement safety chain is needed, see your local Meyer dealer and do not operate on public roads until you are able to travel with the safety chain properly installed.

6.9.2 Tractor Towing Size Requirements

Use the following charts to help calculate the minimum tractor weight when towing without implement brakes. The minimum tractor weight, up to 20 mph (33 kph) needs to be two thirds of the box Gross Weight (GW). Gross Weight is calculated by the empty weight of the box and undercarriage combined added to the Load Weight. Then take the Gross Weight and multiply it by 0.667 and you will get the Minimum Required Weight of the Tractor.

Spreader Loaded Weight x .667 = Minimum Tractor Weight Up to 20 mph

Model	MAXIMUM SPREADER GROSS WEIGHT (LBS)	MINIMUM TRACTOR WEIGHT UP TO 20 MPH (LBS)
720	49,880	33,500
865	55,820	37,250

6.9.3 Spreader Brake Information (Optional)

Two optional brake systems are offered for your spreader. A brake system is recommended for any spreader operated on public roads and may be a requirement.

6.9.3.1 Lever Operated Hydraulic Brakes

This brake system is connected to the tractor remote hydraulic ports and is controlled by the tractor's in-cab controls.

865 Only: The two hose system has a hydraulic manifold pressure relief to prevent the pressure to the activating cylinders to exceed the relief valve setting.

Applying hydraulic pressure from the tractor causes tractor hydraulic fluid to activate the 720 cylinder or 865 cylinders which apply the brakes.

Applying The Brakes (720) - Gradually activate the tractor spool valve lever forward to apply the brake. The hydraulic hoses should be connected to the tractor port so the spool valve lever gives the expected response. Test this after hooking up. If response is opposite of expected, switch hose to opposite port.

Applying The Brakes (865) - Gradually activate the tractor spool valve lever forward to apply the brake. The hydraulic hose should be connected to the tractor port so the spool valve lever gives the expected response. Test this after hooking up. If response is opposite of expected, reverse the hoses.

Releasing The Brakes - Move the tractor spool valve lever to "the float" position.

IMPORTANT

Simply returning the spool valve lever to the neutral position will not release the brakes.

6.9.3.2 Pedal Operated Hydraulic Brakes

CAUTION

At no time should the brake system be used as a parking brake. With loss of hydraulic pressure, the brakes will lose their holding power.

This brake system is a one hose system. The single hydraulic hose must be connected to the tractor remote pedal port.

Applying The Brakes - Gradually apply the tractor brake pedal to apply the brakes.

Releasing The Brakes - Release the tractor brake pedal to release the brakes.

7.0 OPERATION



CAUTION

DO NOT allow anyone to operate, service, inspect or otherwise handle this spreader until all operators have read and understand all of the instructional materials in this Operator's and Parts Manual and have been properly trained in its intended usage.

Before operating the spreader, look in all directions and make sure no bystanders, especially small children are in the work area.

Do not climb or step on any part of the spreader at any time.

Turn on level ground. Slow down when turning.

Go up and down slopes, not across them.

Keep the heavy end of the machine uphill.

Do not overload the machine.

Check for adequate traction.

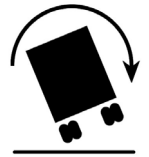

7.1 LOADING



CAUTION

Shutoff and lockout power before performing machine service, adjusting, maintaining, or clearing an obstruction from this machine. Refer to section 5.3 SHUTOFF & LOCKOUT POWER.

IMPORTANT

Do not use the jack except when the implement is empty. The jack will not support added weight. Unbalanced weight may result in unexpected "TIP UP" of the implement.

IMPORTANT

Overloading may cause failure of axles, tires, structural members, hitches, loss of vehicle control. **DO NOT** exceed maximum gross weight.

IMPORTANT

This machine is not intended to be a bale grinder, hay chopper or bedding machine. Failure to comply may damage the drivetrain and void the warranty.

IMPORTANT

Filling the spreader evenly from the front to rear will ensure there is downward force on the tractor hitch and provide traction for the tractor wheels.

IMPORTANT

It is unlawful to allow manure to splash or leak onto public roads.

NOTE: Heaping material over the sides of the box will add a significant amount of weight to the load.

NOTE: To prevent damage to spinners and drivelines, foreign objects (stones, concrete, timber, metal or large frozen chunks of manure) should never be loaded into the spreader.

Before loading, especially in freezing weather, make sure the augers and spinners are free to rotate and the rear gate moves freely up and down.

When the spreader is parked for loading, shift the tractor to neutral or park and set the brakes.

NOTE: Check and be sure that the rear end gate is completely closed before loading. This gate must be closed during loading to prevent packing of material into the beaters and to help prevent leakage during transport.

MATERIAL ESTIMATED WEIGHT PER CUBIC FOOT	
MATERIAL	(LBS / CU. FT.)
Lime Sludge	110 - 115 lbs.
Dry Feedlot Manure	63 - 65 lbs.
Chicken Litter	63 - 65 lbs.
Cake Sludge	62 - 65 lbs.
Semi-Solid Manure	58 - 60 lbs.
Pen Packed Manure	30 - 35 lbs.
Liquid Manure	63 - 65 lbs.
SAE D384.2	

NOTE: Maximum Gross Weight is the lesser value between the implement or tires.

NOTE: Overloading can have detrimental effects on the integrity of the spreader and its safe use. Some materials such as lime sludge may not be able to be filled to struck level. Overloading will void warranty and increase risk to the operator's safety. Always be aware of your gross weight.

MODEL	MAXIMUM SPREADER GROSS WEIGHT	TOTAL NET WEIGHT (LBS)	CU. FT. CAPACITY**	CAPACITY IN GALLONS
720	49,880	14,680	468	3,500
865	55,820	17,820	562	4,200

** Struck capacity, heaped loads significantly increase weight.

Drive alongside the loading vehicle. Fill the spreader evenly to properly distribute the load while loading. When dumping into the box with an end-loader, center the bucket just forward of the axle to properly distribute the load while loading.

A hydraulic lid is available to aid in the containment of liquids.

7.2 UNLOADING



Make certain all personnel are clear of the spreader and the rotating spinners before applying power. Failure to heed may result in serious personal injury or death.



The unloading process described is to be performed by the operator alone. This will eliminate unexpected "start-ups" and minimize other hazards that could result by more than one person in control.



Shutoff and lockout power before performing machine service, adjusting, maintaining, or clearing an obstruction from this machine. Refer to section 5.3 SHUTOFF & LOCKOUT POWER.

NOTE: Unloading is best observed from the operator's seat.

1. Move the tractor / truck and spreader to the unloading area.

2. **Mechanical Driven Spreader:**

When you are ready to begin spreading application on the field, open the rear gate and slowly engage the tractor PTO clutch. This can be done while traveling forward to avoid a heavier application of liquid manure at the edge of the field than desired.

Hydraulically Controlled Augers (Optional):

When you are ready to begin spreading application on the field, open the rear gate and slowly engage the tractor PTO clutch before turning the hydraulically driven auger on to the desired application rate. This can be done while traveling forward to avoid a heavier application of liquid manure at the edge of the field than desired.

All Spreaders:

For liquid and semi-liquid manure, the rear gate can limit the application rate by how far it is opened. The gate indicator on the front of the box will provide a ready reference for the amount of opening. For solid manure (dry, pen-packed or manure containing long straw or hay) the rear gate **MUST be completely open** since this material is not free flowing.



FLOW CONTROL GATE INDICATOR

The rear spinners have been designed and tested to provide the best spread pattern for most liquids and semi solid manure. However, the pattern will vary for each specific condition. The factors that contribute most to differing patterns and widths will be moisture content and the amount and length of bedding material. For most typical conditions, the spread pattern should be uniform and about 25-35 ft. wide. When this is the case, plan your spreading patterns so you do not have to travel over previously spread manure which will be slippery, resulting in poor traction. Traction on wet grass is also poor. When the resulting pattern may require that you overlap during spreading, use precautions on slopes and hills where you could experience a loss of traction by traveling over ground with previously spread manure.

NOTE: Further control of the application rate is possible by the relationship of tractor engine speed to ground speed (transmission gear selection). For optimum, trouble-free performance it is recommended to operate at or near engine PTO speed.

3. When the spreader is empty, idle the tractor and stop the PTO.
4. Close the rear gate.

NOTE: Failure to idle the tractor before disengaging the PTO will cause roller chain over-running and damage to the chain tighteners.

NOTE: Maximum life of the PTO shaft universal joints will result if you stop the PTO while making turns at the end of the field.

7.2.1 PTO Cutout Clutch

Spreaders are equipped with a cutout type clutch on the implement half of the PTO driveline. The clutch is designed to limit the amount of torque transferred to the machine through the driveline. If excessive torque is developed the clutch will disengage. A loud ratcheting sound will be heard and the transfer of power to the machine will be disrupted. To re-engage the machine, turn the PTO to off and allow the driveline to come to a stop. The PTO can then be re-engaged to restart the spreader. The cutout clutch will either re-engage upon shut down of the PTO or just before it comes to a complete stop.

The cutout clutch will disengage if start up is done in an abrupt or reckless manner. It will also disengage from foreign materials entering the expeller area of the spreader. If PTO clutch fails to re-engage it will be necessary to remove the foreign object from the spreader before restarting.

7.3 SHEAR SPROCKET

The Meyer Spreader you have received has been equipped with a shear sprocket design on the main auger drive sprockets. The augers are being driven by two allen head grade 8 bolts. The design is such that if the bolts are sheared, another set of holes to install new shear bolts will always be accessible without turning over the machine.

The plate sprocket is set up with the initial drive bolts being 9/16" diameter. Install the new bolts in the proper way as to drive off of **THE HEAD** of the bolt, not on the nut.

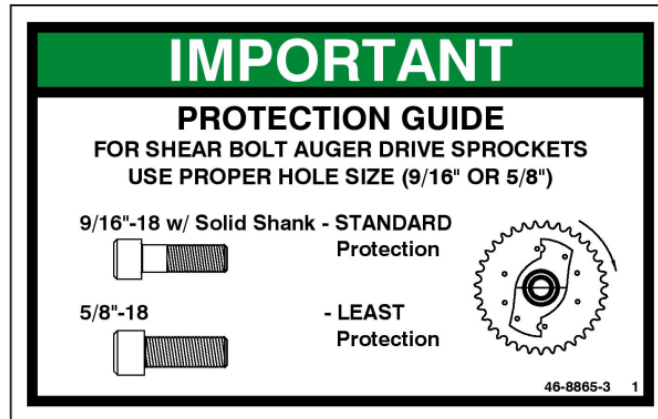

PART NO.	DESCRIPTION
831-5618-1.50-SL	9/16-20 x 1-1/2" Allen Head Cap Bolt
884-5618	9/16-20 Top Locknut Grade 8
831-6318-1.5	5/8-18 x 1-1/2" Allen Head Cap Bolt
884-6318	5/8-18 Top Locknut Grade 8
910-0100	140B35 Shear Sprocket Assembly Complete

7.4 FREEZING WEATHER OPERATION

Allow spreader to completely empty the last of its contents, shutoff and lockout power, and allow all movement to stop before attempting to clean the spreader.

Scrape clean any remaining debris from inside the rear of the spreader.(Augers, Rear Gate, & Spinners). Make certain that all personnel are clear of the spreader and the rotating spinners before slowly engaging the PTO. Operate the spreader several minutes to clean manure scrapings and to allow any remaining manure and the spreader to freeze dry. Hydraulically run the rear gate up and down to clean the gate slides. Park the spreader with the gate halfway open.

Before loading in freezing weather, make sure augers and spinners are free to rotate, and the rear gate moves freely up and down.



Shutoff and lockout power before performing machine service, adjusting, maintaining, or clearing an obstruction from this machine. Refer to section 5.3 SHUTOFF & LOCKOUT POWER.

7.5 UNHOOKING THE TRACTOR

1. Park the implement on level ground. Put the tractor controls in neutral, set the parking brake, and turn the engine off before dismounting.
2. Place wheel chocks in front and in back of the implement wheels on opposite sides to prevent the implement from rolling after the tractor is unhooked.
3. Remove the hydraulic hose ends from the tractor hydraulic ports and secure the hose ends on the front of the box to keep them clean.
4. Remove the light cords and any optional equipment connections.
5. Remove the PTO drive shaft yoke from the splined tractor PTO shaft and store in the provided support bracket.
6. Remove the jack from the storage mount and install it on the hitch tongue. Crank the jack down until the hitch lifts off the tractor draw bar.



WARNING

Jack is not designed to support the implement when it is loaded.

7. Remove the hitch pin.
8. Unhook safety chain from tractor drawbar and intermediate support.
9. Slowly drive the tractor away from the implement.



8.0 MAINTENANCE

8.1 LUBRICATION



CAUTION

Shutoff and lockout power before performing machine service, adjusting, maintaining, or clearing an obstruction from this machine. Refer to section 5.3 SHUTOFF & LOCKOUT POWER.

IMPORTANT

Fluid such as hydraulic fluid, grease, etc., must be disposed of in an environmentally safe manner. Some regulations require that certain spills and leaks on the ground must be cleaned in a specific manner. See local, state and federal regulations for the correct disposal.

IMPORTANT

Failure to grease the CV center housing and telescoping members will reduce the life of the CV joint.

NOTE: Use a grease type that is composed of a high quality lithium complex or better, unless otherwise stated. We recommend using a #1 grade in colder temperatures or a #2 grade in warmer temperatures.

NOTE: Do not mix synthetic and mineral oils.

NOTE: It is very important that the quantity of oil in the gearboxes does not exceed what is indicated. An excessive quantity of oil in the gearboxes would cause a rise in temperature, and therefore shorten its life.

NOTE: *Estimating 5 minutes of run time per load.

8.1.1 Daily Lubrication (Every 8-12 Loads*)

L1 Grease (3) nylon bearings that support both augers and the second reduction jack shaft. The bearings are grease line fitted to the lower zerks on the right front side and left front side grease banks of the spreader. Over greasing is not possible.

L2 Keep oil reservoir full with new 30 weight oil for chain lubrication. The automatic chain oiler will lubricate the chains every time the rear gate cylinder is opened. The oil reservoir is accessible by opening the front shield.

L3 Maintain the oil levels in the (4) gearboxes using each gearbox's sight glass. Check regularly for any observable oil leakage around the input or output shaft seals. If leakage is found, replace seals. Lubricate the (4) gearboxes with Synthetic EP Gear SAE 90/ISO220 oil.

8.1.2 Weekly Lubrication (Every 65-70 Loads*)

L4 Grease PTO (4) places every 8 hours of operation.

L5 Lubricate the outer CV cross kit with about 5 pumps of grease every 8 hours of operation.

L6 Grease telescoping members until it adequately covers the sliding members every 8 hours. Take apart occasionally to make sure adequate lubrication is being added. Take apart each season to be cleaned with solvent and re-coated with grease before re-assembling.

L7 Lubricate the inner CV cross kit with about 15 pumps of grease every 8 hours of operation.

L8 Lubricate the double yoke with about 10 pumps of grease every 8 hours of operation.

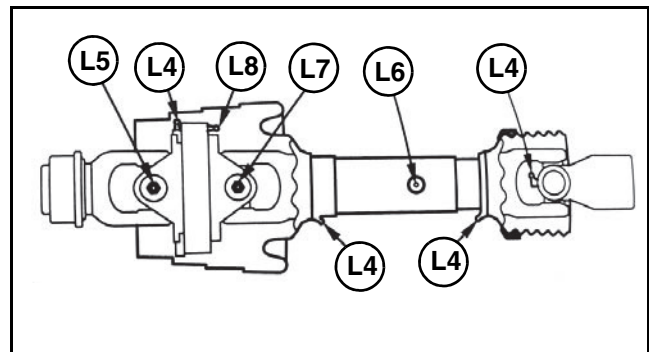

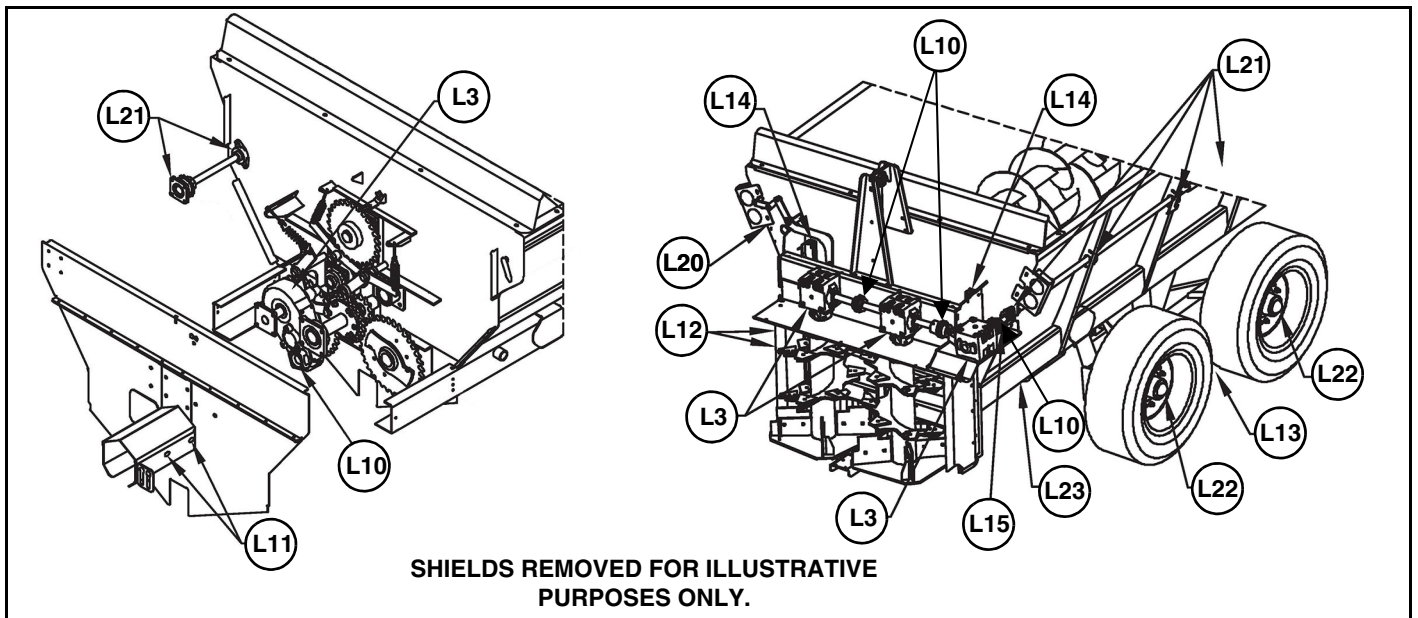

(L10) Lubricate (4) chain couplers on the front and rear drive with new 30 weight oil. The couplers are accessible by opening the front and rear shield.

(L11) Grease (2) PTO input shaft bearings with approximately 1 pump of grease. The bearings are accessible on the left side of the PTO cover shield.

(L12) Grease (2) rear spinner lower bearings with approximately 2 pumps of grease. The bearings are grease line fitted to the left rear frame channel of the spreader.

(L13) Grease (2) tandem wing pivots. Over greasing is not possible.

(L14) Grease (2) rear gate slide guides. Grease the slide guides from the top side with the rear gate opened. Allow grease to lubricate rear gate ends and slide guide surfaces. In freezing weather, dump used motor oil down each slide guide once a week or more often if needed. Over greasing is not possible.

(L15) Grease (1) integral overrunning clutch on the spinner transfer shaft connection to the corner gearbox.

8.1.3 Monthly Lubrication (Every 260-300 Loads*)

(L16) Grease (2) jack assembly zerks located on the front face of the jack and grease (2) hitch zerks.

(L17) Grease the (1) front drive bearing supporting the third auger drive shaft with approximately 1 pump of grease. The zerk is accessible by the left front side grease bank of the spreader. Be careful not to over grease.

(L18) Grease the (2) front drive bearings supporting the first reduction drive shaft with approximately 2 pump of grease. The zerks are accessible by the right front side grease bank of the spreader. Be careful not to over grease.

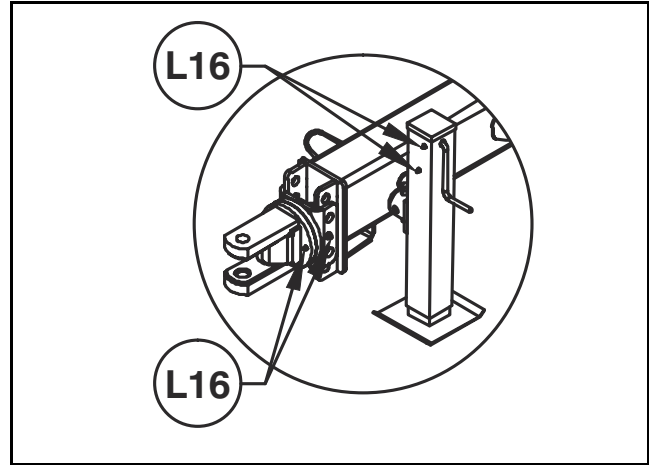

(L19) Grease the (1) front drive bearing supporting the second reduction jack shaft with approximately 3 pump of grease. The zerk is accessible by the left front side grease bank of the spreader. Be careful not to over grease.

(L20) Grease (1) nylon bushing supporting the rear shaft of the 3rd auger assembly. The zerk is grease line fitted to the left rear corner of the tank below the light bracket.

(L21) Grease (6) bearings on the right hand side drive shaft with approximately 1 pump of grease. The second bearing is grease line fitted to the right front side grease bank. The front bearing is accessible behind the front belt drive shield. The remaining rear bearings are located along the right hand side of the spreader tank. The zerks are accessible through the steel shielding.

(L22) Grease the hubs through the zerk in each hub. Be careful not to over grease and force the seal out of the back side of the hub.

(L23) Grease (2) T-post hold down sleeve zerks located at the rear right side of the spreader.

8.1.4 Break-In Lubrication (First 360-500 Loads*)

(L3) Change oil in the (4) gearboxes. Lubricate the (3) rear gearboxes with Synthetic EP Gear SAE 90/ISO220 oil, capacity approximately 81.2 oz. Lubricate the front gearbox with Synthetic EP Gear SAE 90/ISO220 oil, capacity approximately 176.4 oz.

8.1.5 Annual Lubrication

(L3) Change oil in the (4) gearboxes. Lubricate the (3) rear gearboxes with Synthetic EP Gear SAE 90/ISO220 oil, capacity approximately 81.2 oz. Lubricate the front gearbox with Synthetic EP Gear SAE 90/ISO220 oil, capacity approximately 176.4 oz.

(L22) Clean and repack the wheel hubs with axle grease.

8.1.6 Automatic Chain Oiler



CAUTION

Shutoff and lockout power before performing machine service, adjusting, maintaining, or clearing an obstruction from this machine. Refer to section 5.3 SHUTOFF & LOCKOUT POWER.



WARNING

Hydraulic fluid escaping under pressure can have sufficient force to cause injury. Keep all hoses and connections in good serviceable condition. Failure to heed may result in serious personal injury or death.

The automatic chain oiler attachment gives a squirt of clean oil to all roller chains every time that the spreaders rear gate, hydraulic cylinder is activated. In this way, the spreaders roller chains get oiled in direct proportion to the number of hydraulic cylinder cycles of the rear gate. This assures adequate lubrication.

New 30 weight oil, which is placed in the reservoir tank mounted on the spreader is all that is needed to properly lubricate all roller chains and sprockets. The automatic chain oiler does not use any oil from the tractor's hydraulic system. The hydraulic hose connected to the bottom of the oiler pump only serves to power the piston in the pump every time that the spreader's rear gate is opened.

Should the oil reservoir tank run dry, pour about a 1/2 cup of clean 30 weight oil into the tank. Allow time for the oil to run down into the oiler pump slowly and allow air to escape. After thirty minutes to one hour has passed, finish filling the reservoir tank. Make sure that all fittings and brackets are tight when finished filling the tank.

While running the tractors hydraulics only, open and close the spreaders rear gate several times. This will cycle the hydraulic cylinder leading to the oiler pump. Keep cycling until oil can be seen in all of the oil lines leading to the oiler brushes. (If you experience problems priming the oiler pump, you may need to bleed air out of the hydraulic hose where it is connected to the pump. Crack the fitting until oil comes out, and then re-tighten.) The hydraulic cylinder that the oiler pump is tied into is double acting and must reach 300 PSI of pressure to actuate the pump.

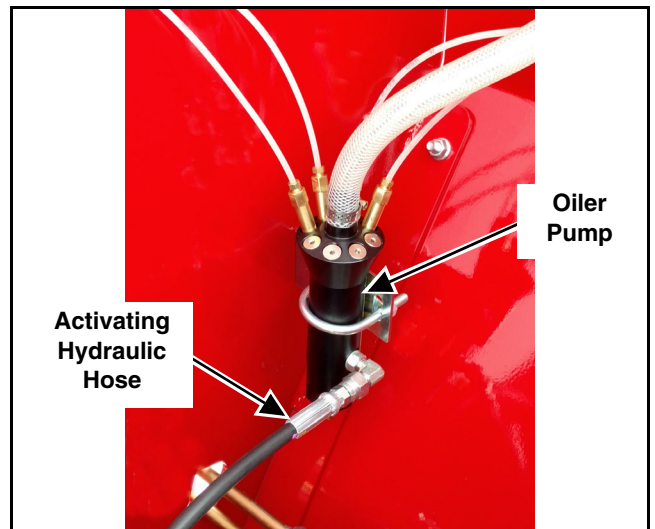

When replacing oiler brushes into brush holders, use regular 1/2"-20 nuts. Tighten nut finger tight initially as some adjustment may be needed later. For best results, place brush holders over top of roller chains and directly on top of sprockets. Adjust brush holders so oiler brushes are pushed down into the roller chain approximately 1/2". Carefully tighten up the 1/2"-20 nuts on the oiler brushes. DO NOT over tighten as damage to the brush will occur. The plastic threads of the oiler brush will crack and then break off from the brush body.

IMPORTANT

The 5/32" oil line tubing can only be removed from an oiler brush by pushing in on the red plastic ring and pulling the tubing out while holding the ring down.

The oiler pump is set at the factory to deliver the maximum amount of oil per cycle. If less oil is desired, loosen the jam nut on the bottom of the pump and screw in the adjusting shaft 1/4" or approximately 5 turns. It is not recommended to screw the shaft into the bottom of the oiler pump more than 15 turns as this may not allow for proper lubrication of the roller chains.

IMPORTANT

Always use new 30 weight oil. In cold weather, use a SAE 10 or a mixture of two parts of 30 weight oil to one part diesel fuel.

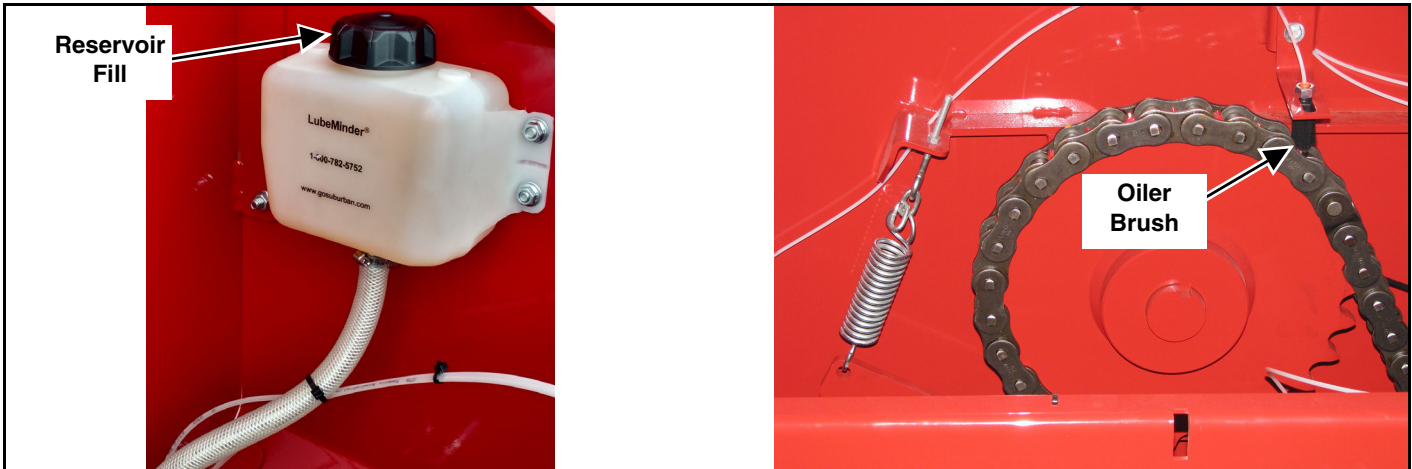

8.2 ADJUSTMENTS

CAUTION

Shutoff and lockout power before performing machine service, adjusting, maintaining, or clearing an obstruction from this machine. Refer to section 5.3 SHUTOFF & LOCKOUT POWER.

8.2.1 Front Drive Roller Chains

There are three roller chain drives located at the front of the spreader. Regularly check that all tensioning springs are in serviceable condition for automatic roller chain tightening. Manually adjust spring tensioners (as needed) by turning locknuts on all tensioning bolt/idler assemblies. The second reduction tensioner spring should be compressed to 3-1/2". The proper roller chain tension for both final drive tensioner springs is when the gap between spring coils measures 1/8" to 3/16". Regularly re-check all roller chain tensions. Keep all roller chains tight at all times!

8.2.2 Front Spinner Drive Belt

Regularly check that the tensioning spring is in serviceable condition for automatic belt tightening. Manually adjust spring tensioner (as needed) by turning locknut on tensioning assembly. Proper belt tension is when there is no gap between spring coils and is collapsed. Regularly re-check belt tension. Keep belts tight at all times!

8.2.3 Balance of Spinners

Review the rear spinners to make sure all paddles are in place and securely fastened. The loss of a paddle or tooth can cause the spinner to be unbalanced, causing damage such as premature bearing failure and cracking to occur to the frame of the spreader. If the spinners are out of balance do not operate until corrective action has been taken.

8.2.4 PTO Cutout Clutch Connection

The cutout clutch end of the PTO driveline must always be attached to the implement. The PTO driveline is equipped with a 1-3/4 x 20 spline on the implement half for attaching to the spreader. Remove the M17-hexagon bolt from the splined hub and slide the PTO onto the implement splined input shaft. Install the hexagon bolt through the hub being sure the bolt is falling into the groove on the splined shaft. Torque tight using a metric size M17 6-point socket and torque down to 75 ft. lbs. A M17 6-POINT METRIC SOCKET MUST BE USED AS ROUNDING OF HEXAGON BOLT AND INACCURACY OF TORQUE SETTINGS COULD OCCUR.

If removal of the M-17 hexagon bolt is necessary, use the same M-17 6-point socket and loosen bolt 1/2 turn. Insert a 1/4" drift punch in the hole on the opposite side of the hexagon bolt and tap to loosen the seated portion of the bolt from the splined hub. Loosen in 1/4 turn increments and tapping to loosen. After bolt seat has been released, remove the bolt. If bolt is not unseated, damage to the hexagon bolt will occur.

Attach the shield safety chain to a suitable area on the spreader, preferably to the implement PTO steel shield.

8.2.5 720 Brake Adjustment

Properly support wheel end to adjust the brakes with the tire assembly removed.

Excessive actuator travel (over one inch) is a sign that the brakes need to be adjusted. Jack wheel/tire off of the ground and rotate tire in the forward direction. The brake adjustment nut is located through a slot at the bottom of the backing plate. Insert brake tool or screwdriver into slotted hole with handle up and bit against the adjusting wheel, pull down on handle and rotate drum in forward direction while tightening. When you can no longer rotate drum in the forward direction, then loosen the large nut on the back side of the brake cluster, located at the 12 o'clock position, one turn, do not take nut completely off, just loosen to allow anchor pin to realign. Take dead blow hammer and tap on brake drum several times around the perimeter, now retighten the large anchor pin nut. Back off adjuster twenty clicks (notches) for two-wheel brake systems and fifteen clicks (notches) for four wheel brake systems, and back off shoe adjuster 10-15 clicks. If there is one spot where the wheel drags just slightly, this is acceptable. As soon as the brake linings are burnished (this requires several braking stops) the brakes will then be set right.

8.2.6 865 Brake Adjustment

Take up the slack when the stroke reaches about two thirds of the maximum travel. Adjust the slack adjuster until the brake shoes make contact with the drum. It may be necessary to jack the tire off of the ground and rotate the tire to feel contact with the drum. Once contact is felt, back off the adjuster bolt on the slack adjuster 1/2 turn or until wheel turns freely without drag. Repeat the same process for the remainder of the brakes.

8.2.7 Wheel Bearing Preload

1. Chock all four wheels or hitch to tractor with engine off, key removed and parking brake set. Jack empty trailer off ground and support with adequate jack stands.
2. Push back and forth on each wheel assembly. If play is detected, bearings need adjusting.
3. If adjusting bearings, it is suggested the bearings be repacked as described previously.
4. Remove hub cap and remove cotter pin from spindle nut.
5. Tighten spindle nut to remove all play. It should be snug and slight drag can be felt while rotating the wheel.
6. If the cotter pin hole in the spindle does not line up with the notch in spindle nut, back off the spindle nut only enough to line up. Reinstall cotter pin. If cotter pin is damaged, replace it.
7. Replace hub cap and lower wheel to the ground.

8.2.8 Truck Mount Die Spring

The truck mount is attached using two hard mounts and four spring tensioned mounts. The springs should be kept at a 4" compression length.

8.3 BRAKES (OPTIONAL)

IMPORTANT

Before using any equipment equipped with brakes, the operation of the brakes should be checked. Brake linings should be replaced before the rivets or support plates come in contact with the wheel drum. Perform all necessary maintenance before using equipment.



WARNING

Any corrosive materials (salt, saltwater, fertilizers, etc.) are destructive to metals. To properly maintain the life of the brake system, flushing with a high pressure water hose is recommended. After washing, be sure to grease actuator bearings (slides) and oil all moving parts. At the end of season, it is recommended that the brake drums be removed and cleaned inside. Repack wheel bearings being careful not to contaminate the brake system with grease. Readjust the brakes.

Check and test the brakes before intensive use and every three months thereafter. Check the brake wear and the clearance between the brake linings and the drum visually. It is probable that the linings are worn when the brake travel has increased significantly. If the linings are worn to the minimum thickness, replace with new.

Check that the brakes are clean and clean them if necessary. Follow the brake adjustment procedure if necessary. (See 8.2.5 720 Brake Adjustment) & (See 8.2.6 865 Brake Adjustment) (865 Only: Lubricate the brake camshaft bearings with grease zerks. To prevent grease from getting on the brake drum or linings, do not over grease.)

8.3.1 720 Brake Bleeding

Before bleeding brakes, fill the system with DOT 3 hydraulic brake fluid. Using a vacuum type brake bleeder (this type of brake bleeder is available at your local automotive store) follow manufacturer's directions for bleeding.

Install bleeder hose on first wheel cylinder to be bled, if tandem bleed rear axles first. Have loose end of hose submerged in a glass container of brake fluid to observe bubbling. By working the manual hand pump, you will draw the air out of the brake lines filling it with fluid.

By loosening the bleeder screw located in the wheel cylinder one turn, the system is open to the atmosphere through the passage drilled in the screw. When the bubbling stops in the glass container, close the bleeder screw securely. Follow the same procedure at each wheel cylinder being sure to maintain the master cylinder fluid level at least one half full of brake fluid. After all wheels are bled fill the master cylinder to 3/8" below the full level.

8.4 WHEELS AND TIRES

8.4.1 Wheel Installation



CAUTION

THESE INSTRUCTIONS ARE NOT COMPLETE. READ AND FOLLOW ALL PROCEDURES IN USER'S GUIDE TO WHEELS AND RIMS BY "THE MAINTENANCE COUNCIL" #T0410. IF YOU HAVE QUESTIONS CALL WALTHER ENG. & MFG. COMPANY INC. (937) 743-8125.

- Clean adjoining surfaces.
- Start nuts to bring wheel and brake drum (If Equipped) flush to hub mounting surface.
- Avoid brake drum (If Equipped) and/or wheel binding on hub.
- Install remaining wheel nuts. Torque to 50 ft-lbs, then re-torque to required full torque (See 8.4.2 Wheel Torque)
- Re-torque wheel nuts after 50-100 miles.
- Check wheel nut torque every 10,000 miles and re-torque as necessary.

8.4.2 Wheel Torque

BOLT/STUD SIZE	SOCKET SIZE	PRESS FORMED WHEEL CENTER	BOLT TYPE	HEAVY DUTY WHEEL CENTER
3/4	1-1/8 / 1-1/2	NA	Flange Nut	378 ft lbs

8.4.3 Tire Inflation

TIRE SIZE	PSI
21.5L-16.1	44
28L-26	28
425/65 x 22.5	75
550/45 x 22.5	58
600/50 x 22.5	70

If tires are to operate for any length of time on roads or other hard surfaces and the draft load is not great, it is advisable to increase the pressure in the tire to the maximum recommendation in order to reduce the movement of the tread bars that causes excessive wiping action.

Inflation pressures should be checked at least every week. Recommended inflation pressures based on total load on tires should be used. For accurate inflation use a special low-pressure gauge with one-pound gradations. Gauges should be checked occasionally for accuracy. Always use sealing valve caps to prevent loss of air.

8.4.4 Implement Tires

Agricultural tires are designed to carry a specified load at a specified inflation pressure when mounted on a specified width rim. When these conditions are met, the deflection of the tire carcass is in the optimum range and maximum tire performance can be expected. If this combination of design factors is altered for any reason, tire performance will be reduced.

Tire Overload or Under Inflation

Tire overload or under inflation have the same effect of over-deflecting the tire. Under such conditions the tread on the tire will wear rapidly and unevenly, particularly in the shoulder area. Radial cracking in the upper sidewall area will be a problem. With under inflated drive tires in high torque applications sidewall buckles will develop leading to carcass breaks in the sidewall. While an under inflated drive tire may pull better in some soil conditions, this is not generally true and not worth the high risk of tire damage that such an operation invites.

Over Inflation

Over inflation results in an under-deflected tire carcass. The tread is more rounded, concentrates tread wear at the centerline area. Traction is reduced in high torque service because ground contact of the tread shoulder area is reduced and the harder carcass, with reduced flexing characteristics, does not work as efficiently. The tightly stretched overinflated carcass is more subject to weather checking and impact break damage.

Pressure Adjustments Required - Slow Speed Operation

Higher tire loads are approved for intermittent service operations at reduced speed. Under such conditions inflation pressure must be increased to reduce tire deflection and assure full tire service life. See 8.4.3 Tire Inflation for proper inflation.

Use of Proper Width Rims

If tires are mounted on rims of incorrect width, the following conditions can result:

- Use of a wider rim results in flattening of the tread face. This feature may improve traction in loose soil conditions. In hard soils, however, the flatter tread penetrates less effectively and tractive effort is reduced. Additional stresses concentrated in the shoulder area tend to increase the rate of shoulder tread wear. By spacing the tire beads farther apart the sidewalls are forced to flex in an area lower than normal and this can result in circumferential carcass breaks and/or separation.
- Use of a narrower rim brings potential mounting problems because the rim shield or flange cover molded into most drive tire designs tends to interfere with the seating of the tire beads on a narrow rim. Once mounted on a narrow rim, the tire shield applies undue pressure on the rim flange, with possible tire sidewall separation or premature rim failure at the heel radius. On a narrow rim the tread of the tire is rounded. As with the over-inflated tire tread wear will be concentrated in the center area of the tread and traction in the field will be reduced.

Roading Of Farm Implement Tires

- Tractor tires operate most of the time in field conditions where the lugs can penetrate the soil, and where all portions of the tread make contact with the ground. In operating on hard roads with low inflation pressure there is an undesirable distortion of the tire during which the tread bars squirm excessively while going under and coming out from under the load. On highly abrasive or hard surfaces, this action wipes off the rubber of the tread bars or lugs and wears them down prematurely and irregularly.
- Farm tractor and implement tires are designed for low-speed operations not exceeding 25 miles per hour. If tractors or implements are towed at high speeds on the highway high temperatures may develop under the tread bars and weaken the rubber material and cord fabric. There may be no visible evidence of damage at the time. Later a premature failure occurs which experience shows was started by the overheated condition that developed when the unit was towed at a high speed.

Care And Storage Of Tractor And Implement Tires

- All tires should be stored indoors in a cool, dark, dry area free from drafts. Both heat and light are sources of oxidation on the tire surfaces - a result of which is crazing and weather checking. Tires should never be stored on oily floors or otherwise in contact with solvents, oil or grease. Further, tires should not be stored in the same area with volatile solvents. Such solvents are readily absorbed by rubber and will damage and weaken it.

- Tires should be stored away from electric motors, generators, arc welders, etc. since these are active sources of ozone. Ozone attacks rubber - to cause crazing and weather checking.
- Unmounted tires should be stored vertically on tread. If stored for an extended period, tires should be rotated periodically to reduce stress concentrations in the area of ground contact. Tires should not be stored flat and "stove piped" as they will become squashed and distorted, making mounting on the rim difficult - particularly for tubeless tires.
- Inflated tires mounted on rims should be stored under conditions noted above, with inflation pressure reduced to 10 PSI.

8.5 STORING THE SPREADER

LOCKOUT / TAGOUT the machine / spreader when preparing for storage. (See 5.3 SHUTOFF & LOCKOUT POWER on page 21.)

Sometimes it may be necessary to store your Meyer spreader for an extended period of time. Below is a list of items to perform before storage.

- Fully empty the material from the spreader. (See 7.0 OPERATION on page 31.)
- Thoroughly clean the equipment.
- Lubricate the equipment. (See 8.1 LUBRICATION on page 37.)
- Apply oil to the rear gate and inspect all spreader components for wear or damage. Repair and replace components as necessary.
- Make appropriate adjustments to equipment. (See 8.2 ADJUSTMENTS on page 42.)
- Place hydraulic hoses and 7-pin connector in the storage brackets (if equipped).
- Inspect the hitch and all welds on the equipment for wear and damage.
- Check for loose hardware, missing guards, or damaged parts.
- Check for damaged or missing safety signs (decals); replace if necessary.
- Replace worn or damaged parts.
- Touch up all paint nicks and scratches to prevent rusting.
- Place the equipment in a dry protected shelter.
- Place the equipment flat on the ground.

8.6 RETURNING THE SPREADER TO SERVICE

After the Meyer spreader has been in storage, it is necessary to follow a list of items to return the equipment to service.

- Be sure all shields and guards are in place.
- Lubricate the equipment.
- Connect to a truck (if required) and operate the truck and equipment; verify all functions operate correctly.
- Connect to a tractor (if required) and operate equipment; verify all functions operate correctly.
- Check for leaks; repair as needed.



9.0 PARTS REPAIR AND REPLACEMENT

9.1 REPLACEMENT PARTS



WARNING

Before servicing this equipment, ensure that all personnel, including family members are familiar with the equipment and the safety hazards that are present, along with the safety practices that should be observed while working in this equipment.



CAUTION

Inspect the axles, o-beams, spindles, tires, hitches and all safety shielding, safety signs and safety lighting regularly. These parts if not watched closely, could pose potential injury or death. If any part is found in need of repair, follow the SHUTOFF & LOCKOUT POWER recommendations and have qualified personnel repair immediately.

Shutoff and lockout power before performing machine service, adjusting, maintaining, or clearing an obstruction from this machine. Refer to section 5.3 SHUTOFF & LOCKOUT POWER.

IMPORTANT

It is important that everyone who works on this equipment is properly trained to help ensure that they are familiar with this procedure and that they follow the steps outlined above. This manual will remind you when to Shutoff & Lockout Power.

At times, parts on this implement will become worn or damaged. Performing repairs on this implement can pose a risk of injury including death. To reduce risk, the party that will be doing the repair should be very knowledgeable of the implement and the equipment that they will be using to do the repair.

- Review the repair so that a plan can be put together and the proper equipment can be used to repair this implement safely and correctly.
- Personal safety equipment may include items such as safety glasses, protective footwear, hearing protection, gloves, fire retardant clothes, etc.



WARNING

Crushing Hazard

Do Not work under suspended or blocked parts.



- The use of hoists and/or supports may be needed to handle heavy components.
- If the implement is being repaired in the field, make sure the parking brake of the tractor is engaged, the implement is on solid and level ground.
- Welding and torching should be done by properly trained individuals who have proven their skills.

IMPORTANT

Call the factory for any additional details you may need to perform the repair. Some parts may come with instruction sheets to assist in the repair. Instruction sheets may be provided with your parts order. Otherwise, if available, instruction sheets can be e-mailed or faxed for your convenience. Call Meyer Manufacturing Corporation toll free at 1-800-325-9103 or email parts@meyermfg.com.

NOTE: Be environmentally friendly and dispose of any waste materials properly. Recycle when appropriate.



CUTOUT CLUTCH

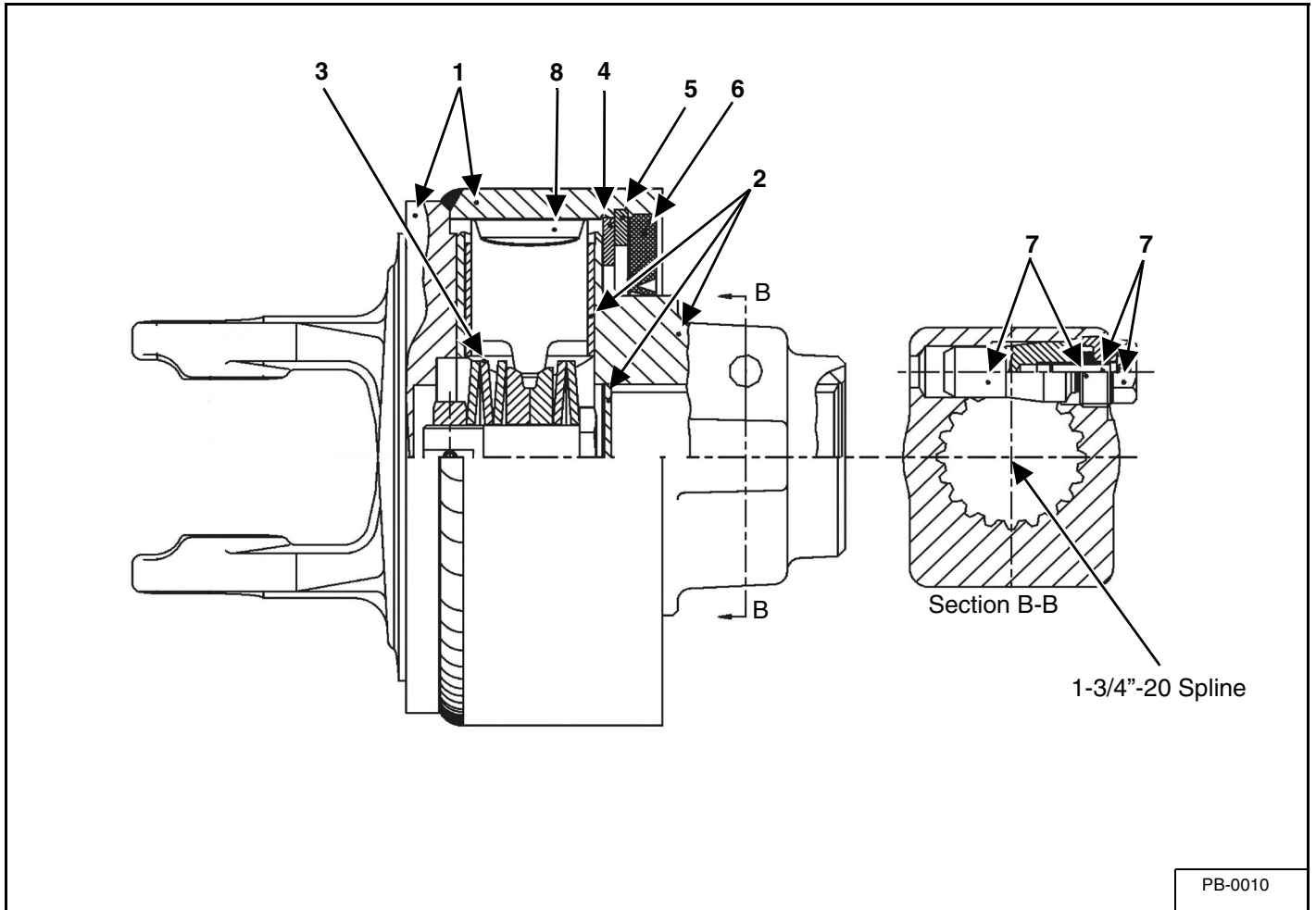

PB-0010

KEY	PART NUMBER	QTY	DESCRIPTION
0	918-0511-2-2	1	Cut-Out Clutch
1	618-0202-2-3-1	1	Housing
2	618-0003-2-1	1	Hub
3	918-0308-2-2-3	1	Spring Pack
4	918-0208-2-3-5	1	Washer
5	918-0208-2-3-6	1	Retaining Ring
6	918-0208-2-3-7	1	Sealing Ring
7	918-0410-2-1-1	1	Clamp Cone Locking Pin
8	918-0308-2-2-4	2	Cam
NS	918-0208-2-3-9	2	Bushing-In Item #2
NS	918-0208-2-3-11	1	Shim Kit

PTO DRIVE SHAFT

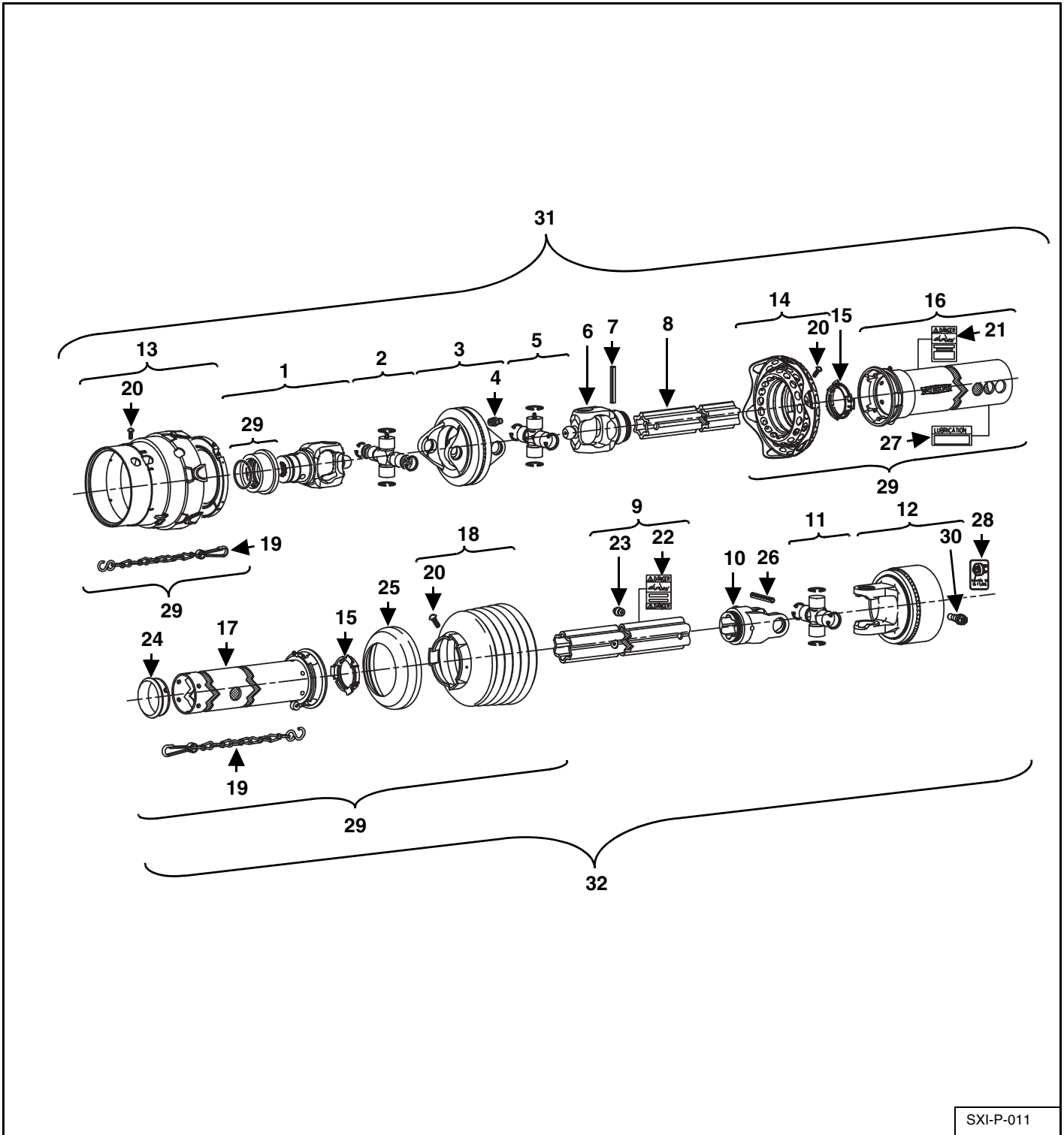

SXI-P-011

KEY	PART NUMBER	QTY	DESCRIPTION
0	918-0511	1	1-3/8" 21 Spline Complete PTO (Standard 720)
	918-0512	1	1-3/4" 20 Spline Complete PTO (Standard 865)(Optional 720)
1	918-0511-1-1	1	1-3/8" 21 Spline Yoke (Standard 720)
	918-0512-1-1	1	1-3/4" 20 Spline Yoke (Standard 865)(Optional 720)
2	918-0511-1-2	1	Cross & Bearing Kit
3	918-0511-1-3	1	Double Yoke
4	918-0208-1-2	1	Grease Zerk
5	918-0511-1-4	1	Cross & Bearing Kit
6	918-0511-1-5	1	Inboard Yoke
7	918-0308-1-5	1	Spring Pin
8	918-0511-1-6	1	Inner Profile
9	918-0511-2-1	1	Outer Profile
10	618-0201-2-2	1	Inboard Yoke
11	618-0201-1-2	1	Cross & Bearing Kit
12	See Page 51	1	Complete Cut-Out Clutch
13	618-0202-1-11	1	CV Guard & Bearing Assembly
14	918-0212-1-5	1	Flex Net & Guard Assembly
15	918-0208-2-4	2	Bearing Ring
16	918-0511-1-7	1	Guard Tube Outer
17	918-0511-2-3	1	Guard Tube Inner
18	618-0202-2-7	1	Guard Cone
19	918-0208-2-7	2	Restraint Chain
20	918-0208-2-9	10	Screw
21	918-0208-2-8	1	Decal Outer
22	918-0208-1-10	1	Decal Inner
23	918-0208-1-12	1	Grease Zerk
24	618-0202-1-10	1	Support Bearing
25	618-0202-2-8	1	Reinforcing Collar
26	618-0202-2-5	1	Spring Pin
27	918-0308-2-6	1	Lubrication Decal
28	918-0208-2-10	1	Decal
29	918-0511-1-1-1	1	Collar Kit (Standard 720)
	918-0210-1-1-1	1	Collar Kit (Standard 865) (Optional 720)
30	918-0410-2-1-1	1	Cut-Out Clutch Lock Assembly
31	918-0511-1	1	Tractor Half Shaft (Standard 720)
	918-0512-1	1	Tractor Half Shaft (Standard 865) (Optional 720)
32	918-0511-2	1	Implement Half Shaft

FIRST REDUCTION AND SPINNER DRIVE

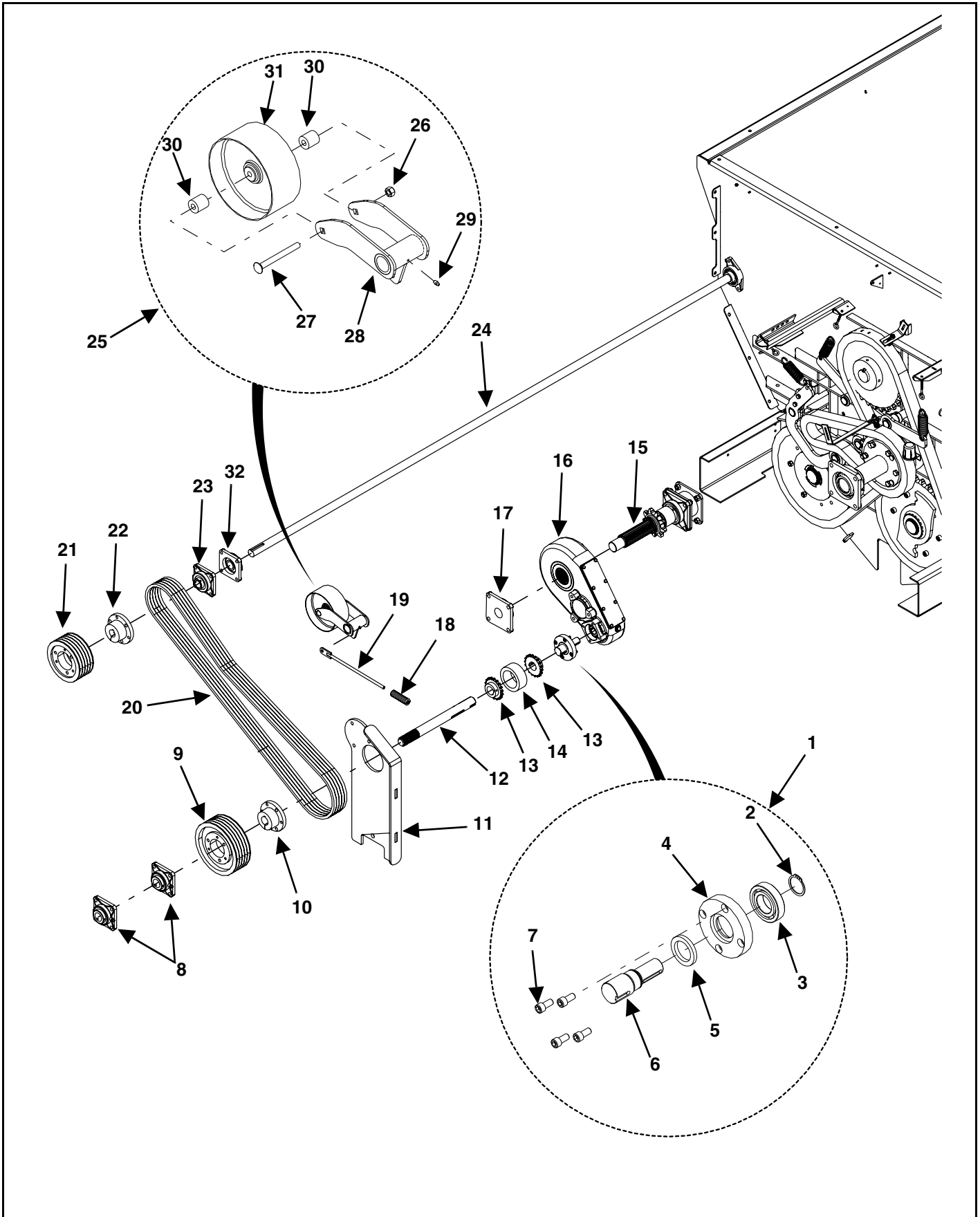

KEY	PART NUMBER	QTY	DESCRIPTION
1	914-0512	1	Input Shaft
2	933-0508	1	External Retaining Ring
3	914-0508-2	1	Bearing
4	914-0508-1	1	Gearbox Input Housing
5	914-0501-3	1	Double Lip Oil Seal
6	923-0537-1	1	Gearbox Drive Input Shaft
7	831-M12-1.75-25	1	M12 x 25 Socket Head Cap Screw
8	914-3819	2	1-3/4" 4-Bolt Flange Bearing
9	12-0059-1	1	10.9" 5 Groove Pulley
10	12-0059-2	1	Quick Disconnect Bushing
11	925-0566	1	Torque Arm Weldment (Pull Type)
	925-0606	1	Torque Arm Weldment (Truck Mount)
12	923-0537-2	1	Gearbox Input Shaft (Pull Type)
	923-0537-3	1	Gearbox Input Shaft (Truck Mount)
13	110-60B18-1.75-1	2	Sprocket (Prior to SN SXI21720237)
	110-60B26-1.75-1	2	Sprocket (SN SXI21720237 & Later)
14	111-0060-18-CC	1	Coupling Chain (Prior to SN SXI21720237)
	111-0060-26-CC	1	Coupling Chain (SN SXI21720237 & Later)
15	See Page 58	1	Second Reduction Drive
16	See Page 56	1	Berma Front Gearbox
17	14-0031	1	2" 4-Bolt Flange Bearing
18	29-0036	1	Spring
19	941-0500	1	Belt Tightener Rod Weldment
20	SXIB-BBP-UP	1	Front Belt Drive Update Kit (Prior to SN SXI21720270)
	49-0531	1	V-Belt (SN SXI21720270 & Later)
21	12-0058-1	1	8.5" 5 Groove Pulley
22	12-0058-2	1	Quick Disconnect Bushing
23	914-3602	1	1-1/2" 4-Bolt Flange Bearing
24	See Page 70	1	Spinners & Gearboxes
25	SXIB-BBP-UP	1	Front Belt Drive Update Kit (Prior to SN SXI21720270)
	12-0071	1	Belt Drive Idler Assembly (SN SXI21720270 & Later)
26	SXIB-BBP-UP	1	Front Belt Drive Update Kit (Prior to SN SXI21720270)
	814-5013-Z	1	1/2" -13 Center Lock Nut (SN SXI21720270 & Later)
27	SXIB-BBP-UP	1	Front Belt Drive Update Kit (Prior to SN SXI21720270)
	850-5013-5Z	1	1/2" -13 x 5" Carriage Bolt (SN SXI21720270 & Later)
28	SXIB-BBP-UP	1	Front Belt Drive Update Kit (Prior to SN SXI21720270)
	12-0071-1	1	Belt Drive Idler Pivot Weldment (SN SXI21720270 & Later)
29	SXIB-BBP-UP	1	Front Belt Drive Update Kit (Prior to SN SXI21720270)
	30-0001	1	1/4" -28 Straight Grease Fitting (SN SXI21720270 & Later)
30	SXIB-BBP-UP	1	Front Belt Drive Update Kit (Prior to SN SXI21720270)
	30-0001	2	Pulley Spacer (SN SXI21720270 & Later)
31	SXIB-BBP-UP	1	Front Belt Drive Update Kit (Prior to SN SXI21720270)
	12-0071-2	1	Idler Pulley (SN SXI21720270 & Later)
32	924-0630-K	1	Bearing Mount Kit (Prior to SN SXI21720262)
	914-3602	1	1-1/2" 4-Bolt Flange Bearing (SN SXI21720262 & Later)

BERMA FRONT GEARBOX

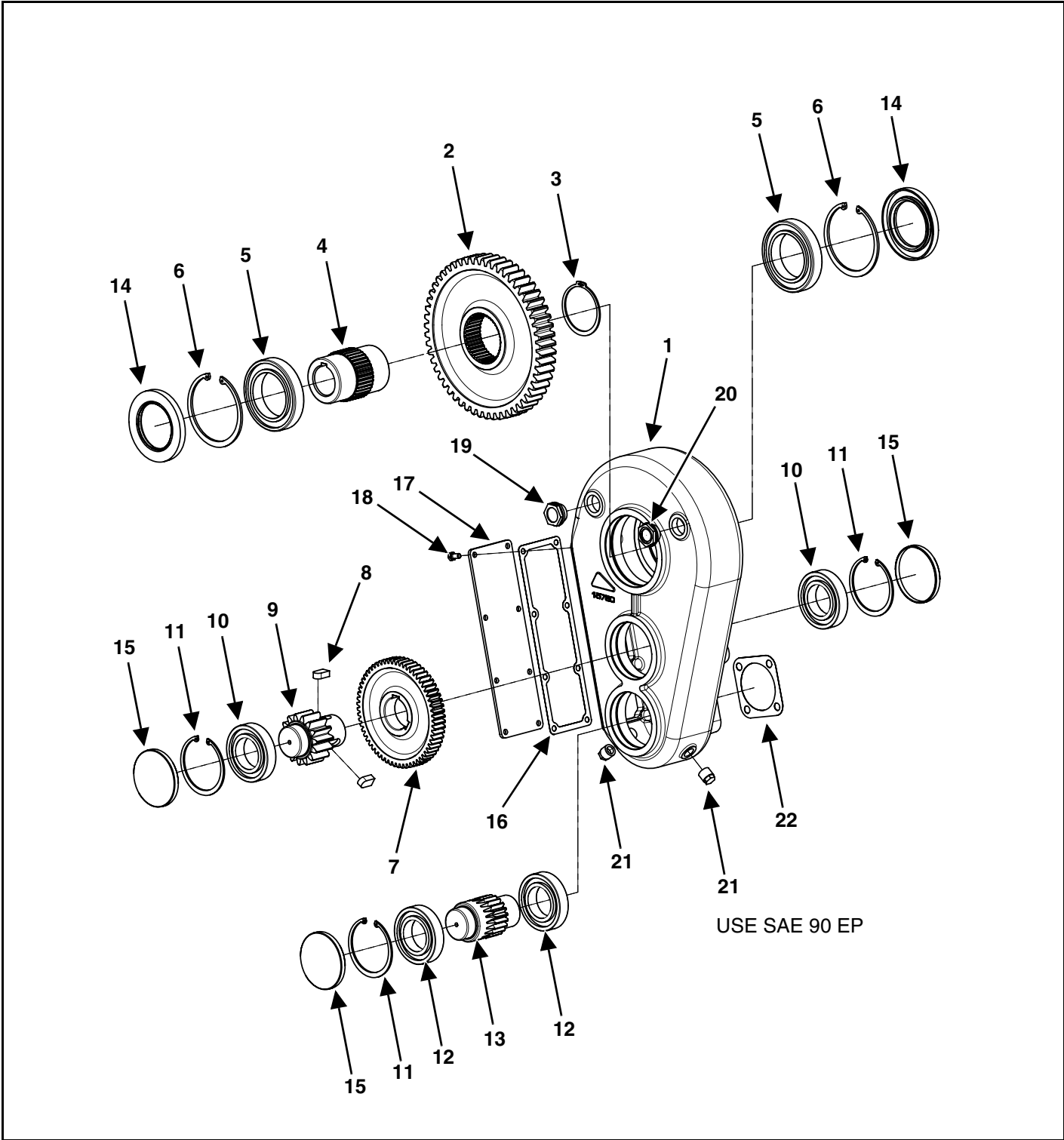

KEY	PART NUMBER	QTY	DESCRIPTION
0	19-0214	1	Berma Front Gearbox
1	19-0204-1	1	Housing
2	19-0204-3	1	Gear
3	19-0201-4	1	Snap Ring
4	19-0214-1	1	Hub
5	19-0204-4	2	Bearing
6	19-0204-5	2	Snap Ring
7	19-0204-6	1	Gear
8	19-0204-8	2	Key
9	19-0204-7	1	Pinion
10	19-0204-17	2	Bearing
11	19-0204-10	3	Snap Ring
12	19-0204-17	2	Bearing
13	19-0211-2	1	Pinion
14	19-0204-12	2	Oil Seal
15	19-0204-13	3	Plug
16	19-0204-14	1	Gasket
17	19-0204-15	1	Cover
18	619-0001-27	8	Cover Bolt
19	619-0001-20	1	Oil Breather Plug
20	619-0001-21	1	Oil Level Indicator
21	19-0204-16	2	1/2" Oil Plug
22	619-0001-28	1	Gasket

SECOND REDUCTION DRIVE

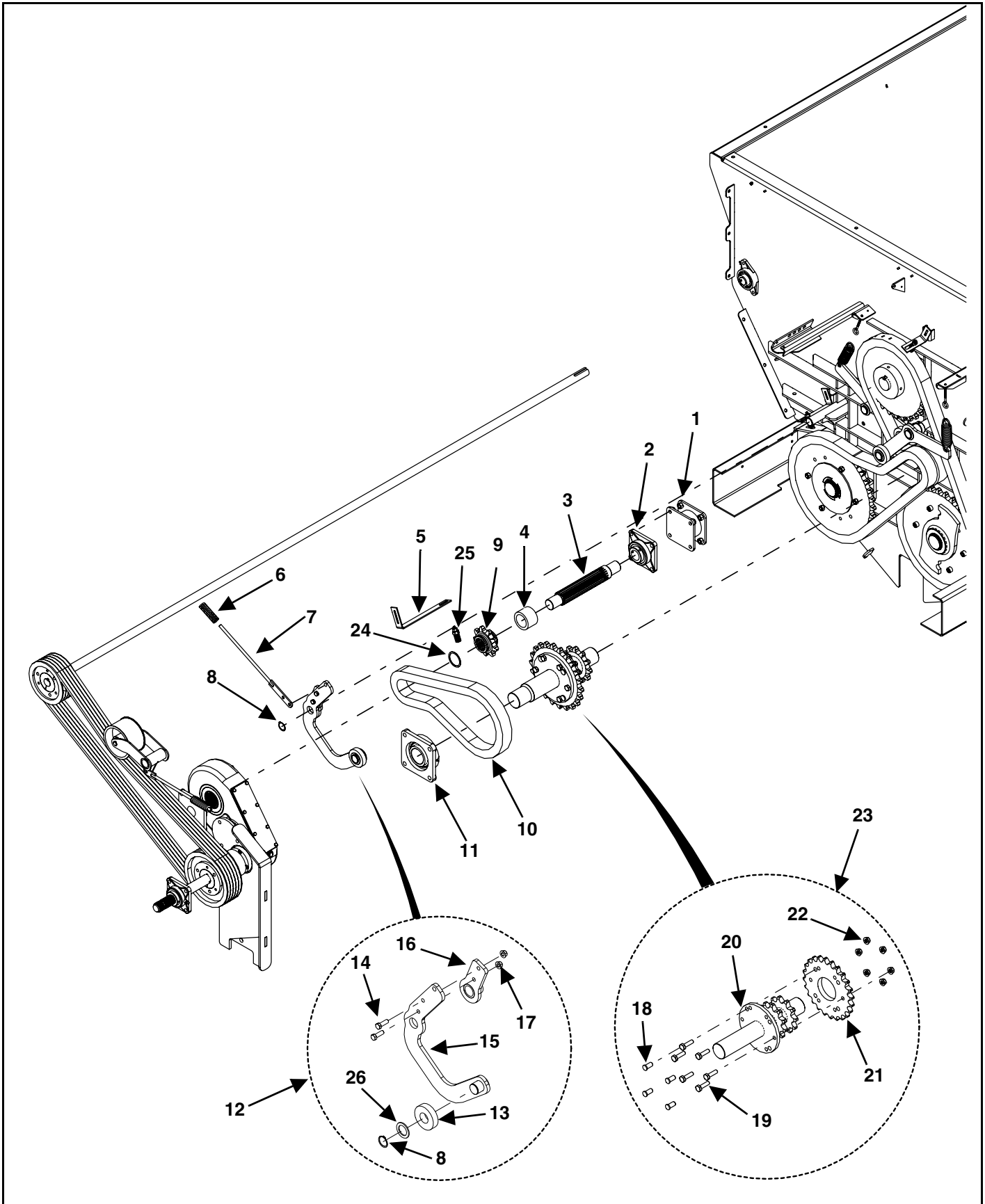

KEY	PART NUMBER	QTY	DESCRIPTION
1	901-0506	1	Bearing Standoff
2	14-0031	1	2" 4-Bolt Flange Bearing
3	923-0517	1	Output Gearbox Jackshaft
4	912-0512	1	Chain Guide
5	25-0538	1	Auger Chain Brush Holder
6	941-0502-UP	1	Second Reduction Spring Tension Update Kit (Prior to SN SXI21720237)
	29-0036	1	Spring (SN SXI21720237 & Later)
7	941-0502-UP	1	Second Reduction Spring Tension Update Kit (Prior to SN SXI21720237)
	941-0502	1	Belt Tightener Rod Weldment (SN SXI21720237 & Later)
8	33-0038	2	1-1/2" External Snap Ring
9	910-0512	1	Sprocket
10	111-0140-37	1	#140-37 Roller Chain Including Connector (Standard 11 RPM Auger)
	111-0140-46	1	#140-46 Roller Chain Including Connector (7.2 RPM Auger)
11	914-0502	1	3" 4-Bolt Flange Bearing
12	925-0600	1	Chain Tightener Assembly
13	912-0016-1	1	7/8" Nylon Roller
14	851-5013-1.5Z	2	1/2-13 x 1-1/2" Cap Screw
15	925-0600-1	1	Chain Tightener Arm Weldment
16	925-0532-2	1	First Reduction Chain Tightener Pivot Tube Weldment
17	810-5013-Z	2	1/2-13 Spin Lock Nut
18	910-0502-5	4	Sprocket Drive Pin
19	851-6311-2.25Z	6	5/8-11 x 2-1/4" Cap Screw
20	910-0531-1	1	Jackshaft Weldment
21	910-0529-4	1	Split Sprocket (Standard 11 RPM Auger)
	910-0531-2	1	Split Sprocket (7.2 RPM Auger)
22	810-6311-Z	6	5/8-11 Spin Lock Nut
23	910-0531	1	Jackshaft Sprocket Assembly (Comes With Standard RPM Auger Split Sprocket)
24	925-0551	1	Sprocket Spacer
25	952-0001-1-25	1	Brush Assembly
26	925-0530-2	1	Tightener Washer

FINAL REDUCTION, RH AUGER DRIVE

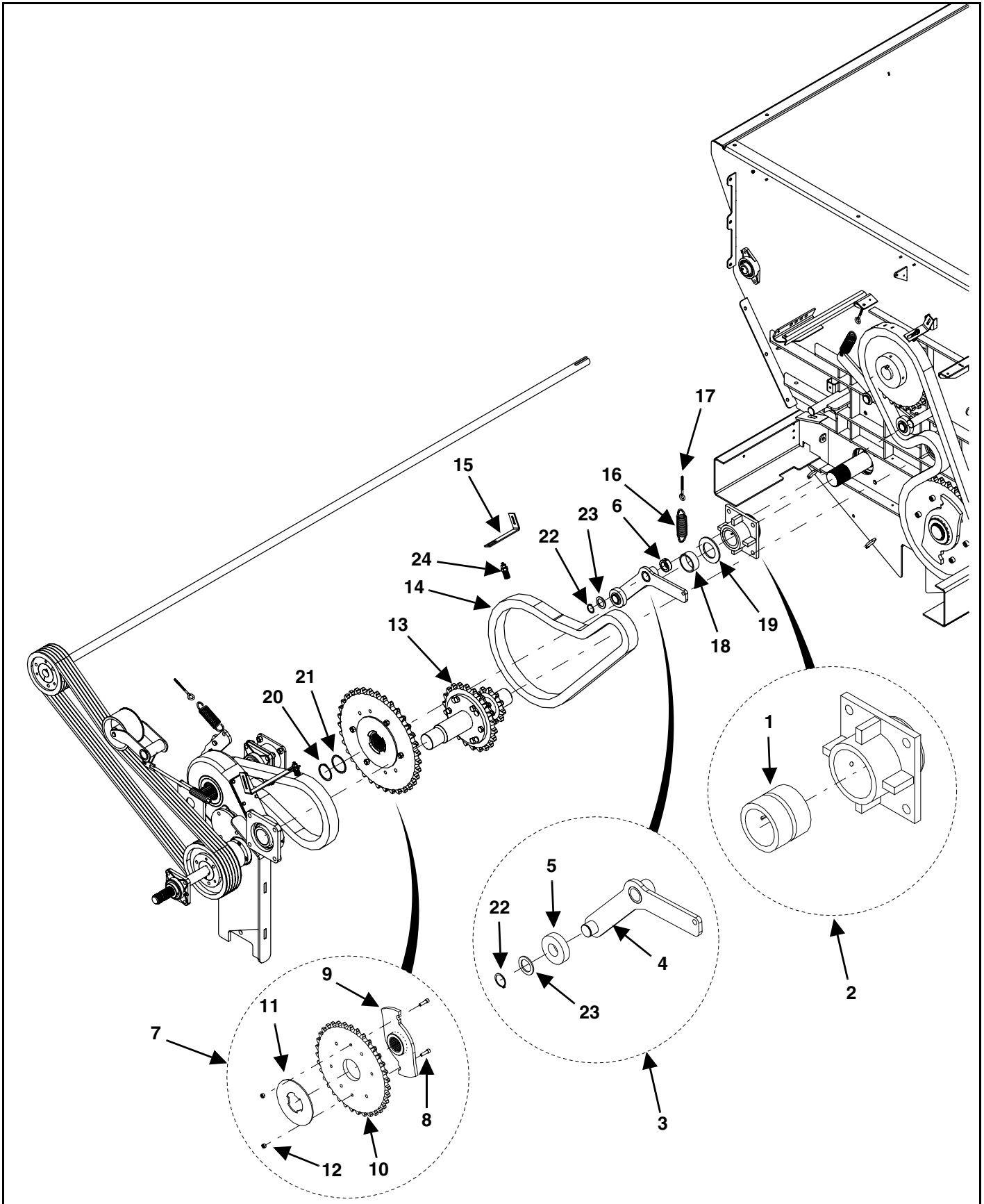

KEY	PART NUMBER	QTY	DESCRIPTION
1	913-3701	1	Nylon Bushing
2	925-3766	1	Front Auger Bushing Assembly
3	925-0530	1	Right Auger Tightener Arm Assembly
4	925-0530-1	1	Right Auger Tightener Arm Weldment
5	912-0016-1	1	Nylon Roller
6	921-0005	1	1-1/2" Set Collar
7	910-0100	1	Shear Sprocket Welded Assembly
8	831-5618-1.50-SL	2	9/16-18 x 1-1/2" Socket Head Screw (Standard Protection)
	831-6318-1.50	2	5/8-18 x 1-1/2" Socket Head Screw (Least Protection)
9	910-0100-1	1	Shear Plate & Splined Hub Welded Assembly
10	910-0100-3	1	Shear Sprocket
11	910-0100-2	1	Shear Washer
12	884-5618	2	9/16-18 Top Lock Nut (Standard Protection)
	884-6318	2	5/8-18 Top Lock Nut (Least Protection)
13	See Page 58	1	Jackshaft Sprocket Assembly
14	111-0140-54	1	#140-54 Roller Chain Including Connector
15	33-8000-7	1	Auger Chain Brush Holder
16	929-0501	1	Extension Spring
17	933-3804	1	5/16-18 x 4" Eyebolt
	925-3822-6	1	2 Chain Links
18	933-0504	1	Right Auger Sprocket Spacer
19	933-3704	1	Front Auger Washer
20	933-3701	1	3" Retaining Ring
21	933-3711	1	Shaft Spacer
22	33-0038	2	1-1/2" External Snap Ring
23	925-0530-2	2	Tightener Washer
24	952-0001-1-25	1	Brush Assembly

FINAL REDUCTION, LH AUGER & THIRD AUGER DRIVE

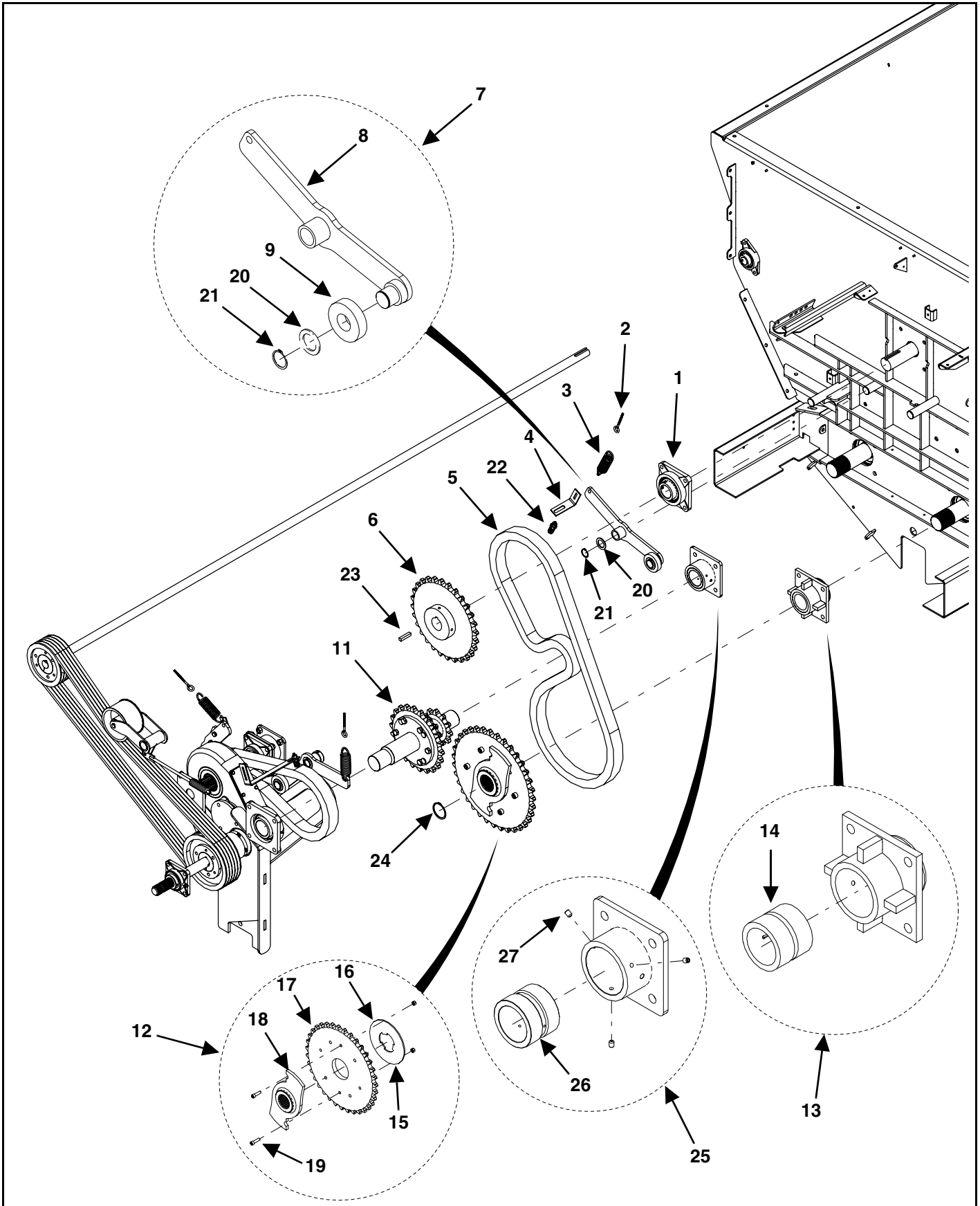

KEY	PART NUMBER	QTY	DESCRIPTION
1	914-3811	1	4-Bolt Flange Bearing
2	933-3804	1	5/16-18 x 4" Eyebolt
	925-3822-6	1	2 Chain Links
3	929-0501	1	Extension Spring
4	952-0001-3	1	Left Auger Chain Brush Holder
5	111-0140-77	1	#140-77 Roller Chain Including Connector & Offset
6	910-0087	1	Third Auger Sprocket
7	925-0529	1	Left Auger Chain Tightener Assembly
8	925-0529-1	1	Left Auger Chain Tightener Weldment
9	912-0016-1	1	Nylon Roller
10	827-3816-.5	3	3/8-16 x 1/2" Knurled Set Screw
11	See Page 58	1	Jackshaft Sprocket Assembly
12	910-0100	1	Shear Sprocket Welded Assembly
13	925-3766	1	Front Auger Bushing Assembly
14	913-3701	1	Nylon Bushing
15	884-5618	2	9/16-18 Top Lock Nut (Standard Protection)
	884-6318	2	5/8-18 Top Lock Nut (Least Protection)
16	910-0100-2	1	Shear Washer
17	910-0100-3	1	Shear Sprocket
18	910-0100-1	1	Shear Plate & Splined Hub Welded Assembly
19	831-5618-1.50-SL	2	9/16-18 x 1-1/2" Socket Head Screw (Standard Protection)
	831-6318-1.50	2	5/8-18 x 1-1/2" Socket Head Screw (Least Protection)
20	925-0530-2	2	Tightener Washer
21	33-0038	2	1-1/2" External Snap Ring
22	952-0001-1-25	1	Brush Assembly
23	35-0024	1	1/2" x 1/2" x 2-1/2" Square Key
24	933-3701	1	3" Retaining Ring
25	914-0503	1	Jackshaft Bearing Assembly
26	914-3824	1	Jackshaft Bearing

BODY & SHIELDS

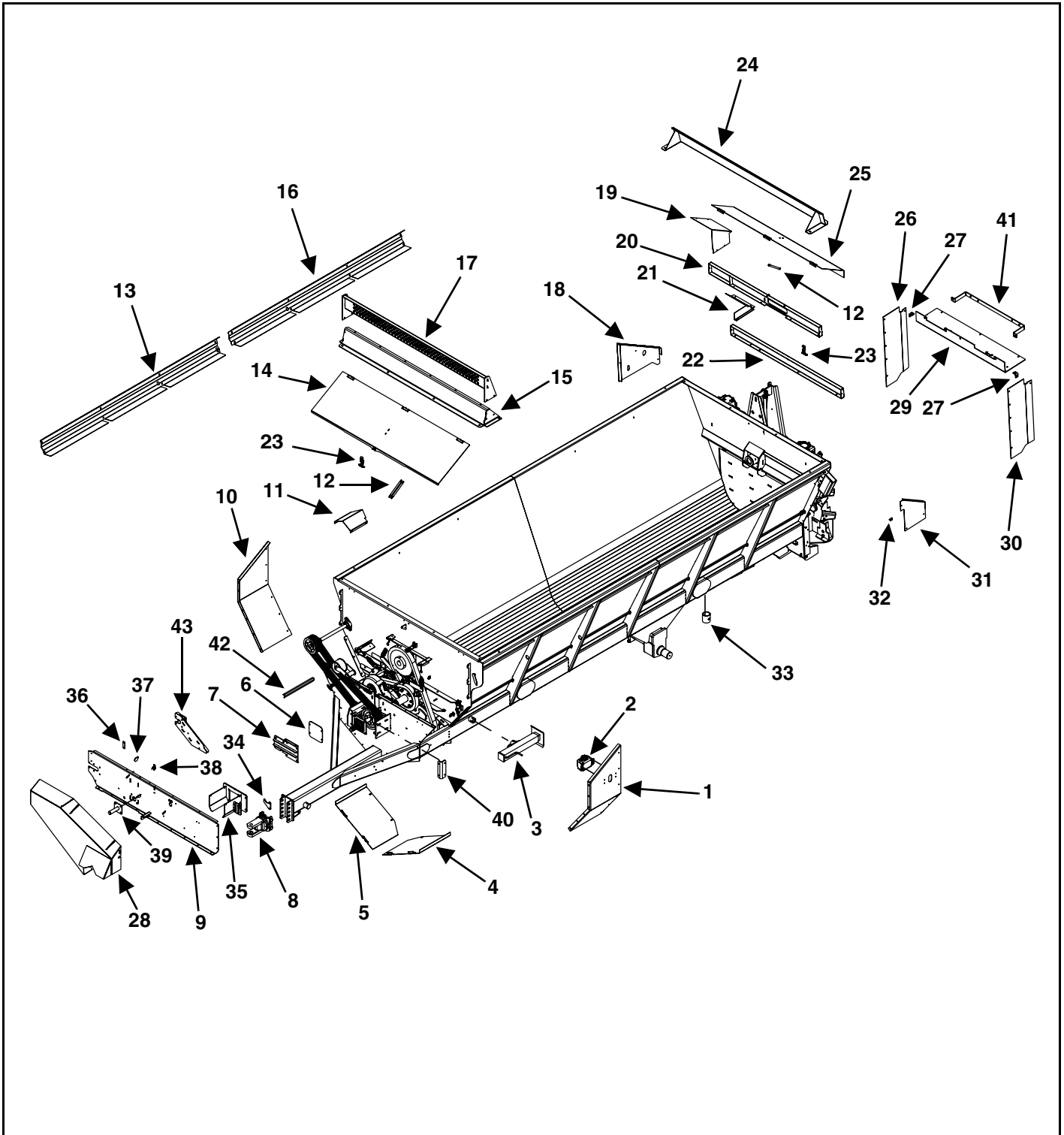

KEY	PART NUMBER	QTY	DESCRIPTION
1	924-0575	1	Left Front Panel
2	See Page 92	1	2 Quart Tank
3	956-3804	1	Jack
4	925-0518	1	Left Side Panel Assembly
	924-0518-1	1	Left Side Panel
	924-0515-2	2	Stainless Steel Shield Hinge
	802T-2520-.63Z	4	1/4-20 x 5/8" Truss Head Machine Screw Zink
	815-2520-Z	4	1/4-20 Nylon Insert Lock Nut
5	924-0504	1	Right Side Panel Assembly
	924-0504-1	1	Right Side Panel
	924-0515-2	2	Stainless Steel Shield Hinge
	802T-2520-.63Z	4	1/4-20 x 5/8" Truss Head Machine Screw Zink
	815-2520-Z	4	1/4-20 Nylon Insert Lock Nut
6	924-0546	1	Motor Cover
7	924-0610	1	Input Panel Cover
8	75-2024	1	Swivel Clevis Weldment With Hardware
	75-2028-KIT	1	Bull Pull Hitch With Hardware (Optional)
	75-2027	1	Hitch Assembly (720 With Scales Only)
	75-2023	1	Clevis Weldment (720 With Scales Only)
9	924-0573	1	Upper Input Panel Weldment (Pull Type)
	924-0613	1	Upper Input Panel Weldment (Truck Mount)
10	924-0557	1	Right Front Panel
11	924-0579	1	Input Shaft Cover
12	955-3703	3	Gas Spring
13	924-0524	1	Front Transfer Shield
14	924-0515	1	Front Top Shield Assembly
	924-0515-1	1	Front Top Shield
	924-0515-2	3	Stainless Steel Shield Hinge
	802T-2520-.63SS	6	1/4-20 x 5/8" Truss Head Machine Screw Stainless Steel
	815-2520-Z	6	1/4-20 Nylon Insert Lock Nut
15	901-0529	1	Splash Guard Weldment
16	924-0526	1	Rear Transfer Shield (720)
	924-0525	1	Rear Transfer Shield (865)
17	901-0530	1	Rock Guard Weldment
18	924-0530	1	Rear Shield End Cap
19	924-0531	1	Rear Shield
20	924-0505	1	Rear Shield Upper Channel Weldment
21	924-0510	1	Rear Shield Weldment

BODY & SHIELDS (CONT'D)

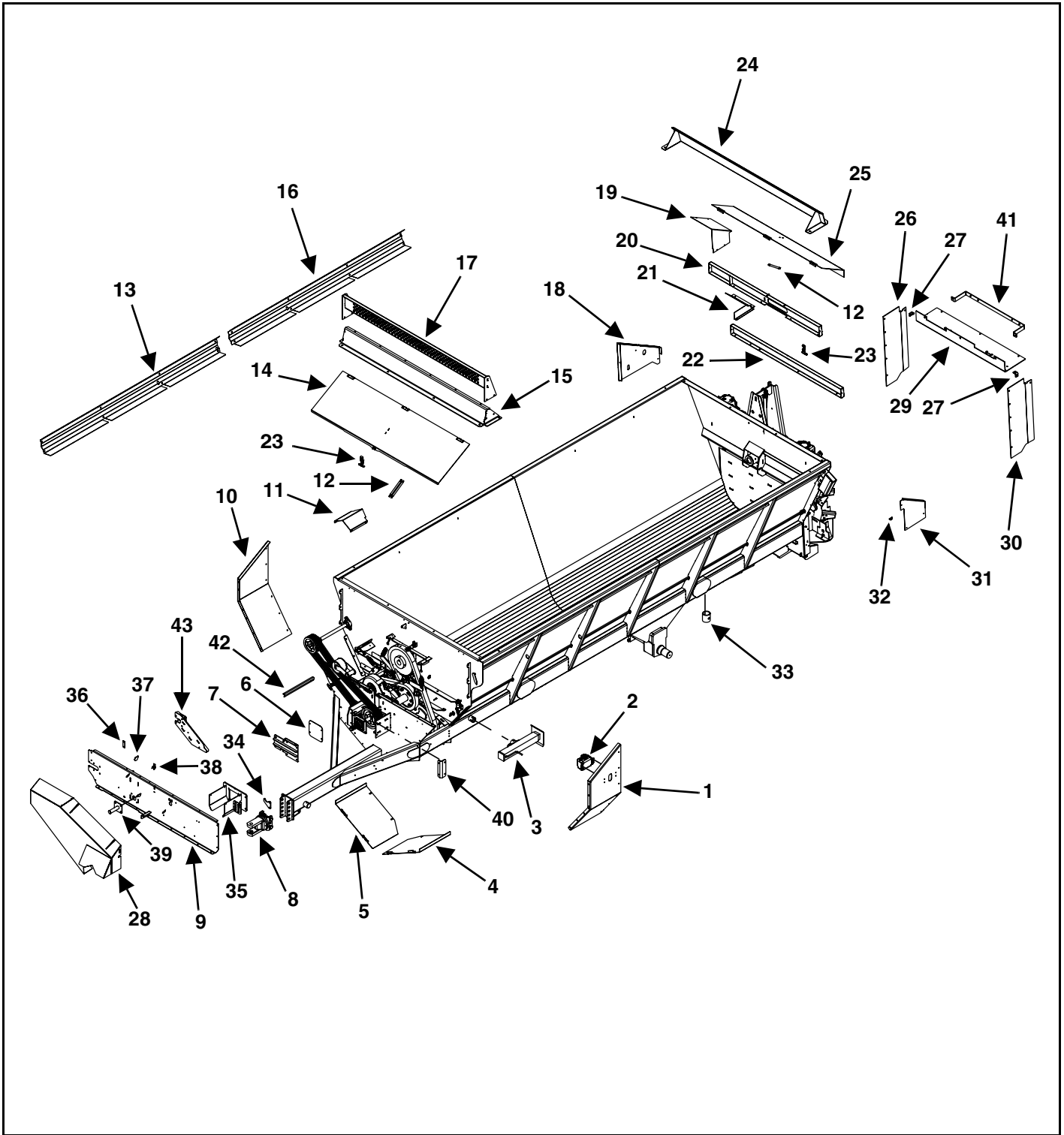

KEY	PART NUMBER	QTY	DESCRIPTION
22	924-0506	1	Rear Shield Channel Weldment
23	32-0027-2	2	Rubber T-Latch With End Piece
24	901-3769	1	Splash Guard Welded Assembly
25	924-0511	1	Rear Shield Assembly
	924-0511-1	1	Rear Shield
	924-0515-2	3	Stainless Steel Shield Hinge
	802T-2520-.63SS	6	1/4-20 x 5/8" Truss Head Machine Screw Stainless Steel
	810-2520-Z	6	1/4-20 Nylon Insert Lock Nut
26	925-0520-4	1	Right Material Guide
27	925-0520-2	2	Rear Shield Mount Tab
28	924-0572	1	Belt Drive Shield Weldment
29	925-0584	1	Spinner Top Shield
30	925-0520-5	1	Left Material Guide
31	924-0598	1	Rear Shield End Cap
32	925-0505	1	Rear Shield Mount Tab
33	See Page 68	1	Auger Hold Down Collar
34	901-0555-1	1	PTO Holder Plate
35	901-0663-9	1	Input Plate Weldment
36	924-0570	1	Cover Plate
37	901-0592-12	1	Front Shield Support
38	32-0027-3	1	Rubber T Lower Catch Keeper
39	925-0624	1	Idler Pivot Weldment
40	901-0729-5	1	Input Mount Plate (SN SXI21865216 & Later)
41	925-0583	1	Gearbox Strap
	851-M16-2.0-25-Z	1	M16-2.0 x 25mm Hex Cap Screw
42	924-0573-3-1	1	Angle Plate
43	924-0630-K	1	Bearing Mount Kit (Prior to SN SXI21720262)
	924-0630	1	Bearing Mount Weldment (SN SXI21720262 & Later)

AUGERS

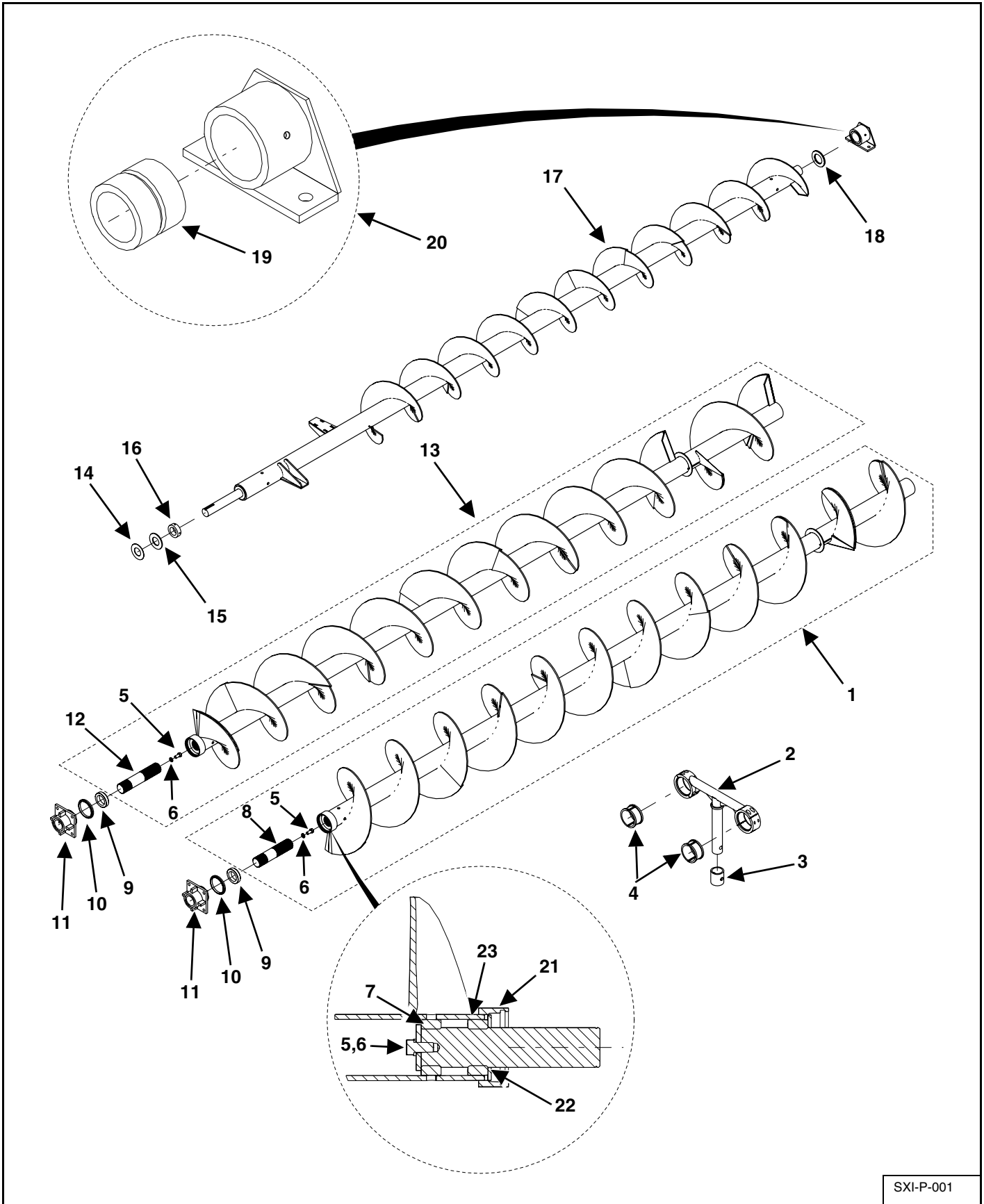

SXI-P-001

KEY	PART NUMBER	QTY	DESCRIPTION
1	926-0504	1	Left Auger Weldment (720)
	926-0501	1	Left Auger Weldment (865)
2	925-3773	1	T-Post Weldment
3	925-3771-4	1	Auger Hold Down Collar
4	925-3864-1	2	Auger Ring Hold Down Nylon Bearing
5	881-7510-1.5	2	3/4-10 x 1-1/2" Machine Bolt
6	822-0075-Z	2	3/4" Split Lock Washer
7	926-3701-2-1	2	Rear Splined Sleeve With Washer Welded Assembly
8	926-3701-1	1	Splined Shaft
9	914-3812-NSM	2	Nylon Auger Thrust Bearing
10	914-3813	2	Seal
11	See Page 60 & 62	2	Front Auger Bushing Assembly
12	926-3770-9	1	Splined Shaft
13	926-0503	1	Right Auger Weldment (720)
	926-0500	1	Right Auger Weldment (865)
14	49-0514	1	Plastic Washer
15	933-3802	1	Front Auger Washer
16	933-3753	1	3rd Auger Collar
17	926-0505	1	3rd Auger Weldment (720)
	926-0502	1	3rd Auger Weldment (865)
18	933-0506	1	Nylon Washer
19	913-3701	1	Auger Nylon Bushing
20	925-3770	1	3rd Auger Bushing
21	926-3750-3	2	Front Auger Bearing Seal Collar
22	933-3704	2	Front Auger Washer
23	926-3701-2	2	Splined Sleeve

SPINNERS & GEARBOXES

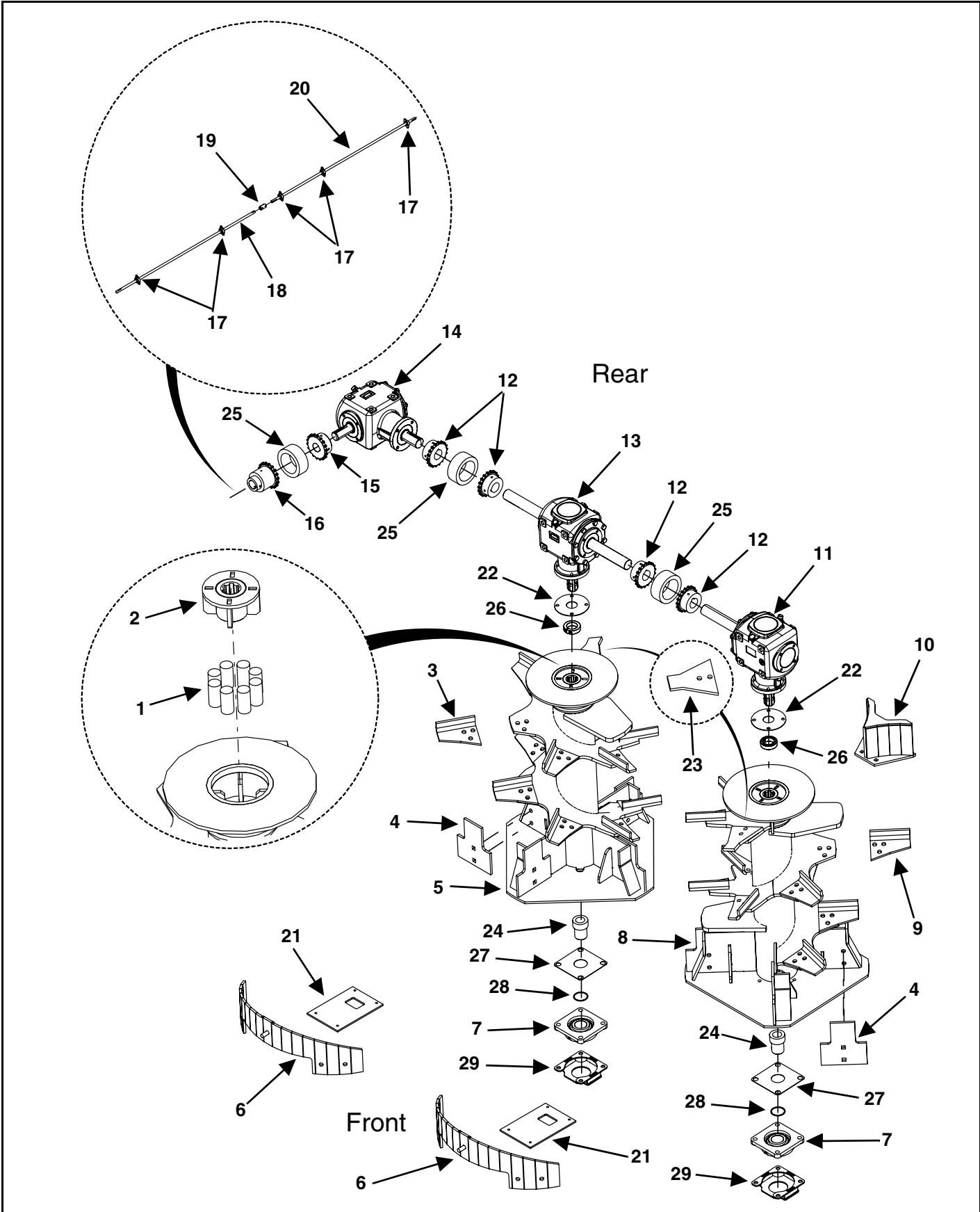

KEY	PART NUMBER	QTY	DESCRIPTION
1	637-0004	16	Polyurethane Coupling Rod
2	901-13811	2	Upper Coupling Hub Weldment
3	901-0562-2	11	Right Spinner Tooth
	881-6311-1.5Z	33	5/8-11 x 1-1/2" Machine Bolt
	886-6311-Z	33	5/8-11 Center Lock Nut
4	901-0564	8	Lower Spinner Paddle
5	901-0562	1	Right Spinner Assembly (Includes Key #'s 1 & 2)
6	901-0556	2	Expeller Liner Weldment
7	914-3834	2	4-Bolt Flange Bearing
	881-6311-2Z	8	5/8-11 x 2" Machine Bolt
	885-6311-Z	8	5/8-11 Nylon Locknut
8	901-0563	1	Left Spinner Assembly (Includes Key #'s 1 & 2)
9	901-0563-2	11	Left Spinner Tooth
	881-6311-1.5Z	33	5/8-11 x 1-1/2" Machine Bolt
	886-6311-Z	33	5/8-11 Center Lock Nut
10	925-0565	1	Standard Spinner Deflector Weldment
	925-0523	1	High Spinner Deflector Weldment (Optional)
11	See Page 76	1	Complete Left Spinner Gearbox
	851-M16-2.0-35-Z	4	M16-2.0 x 35mm Grade 8 Bolt
12	937-0010-1	4	Chain Coupler
13	See Page 74	1	Complete Right Spinner Gearbox
	851-M16-2.0-35-Z	4	M16-2.0 x 35mm Grade 8 Bolt
14	See Page 72	1	Complete Corner Gearbox
	851-M16-2.0-40-Z	4	M16-2.0 x 40mm Grade 8 Bolt
15	937-0009-1	1	Chain Coupler
16	937-0020	1	Overrunning Clutch
17	914-3814	5	2-Bolt Flange Bearing
18	923-0522	1	Spinner Front Transfer Shaft
19	937-0004	1	1-1/2" Coupler With 4 Set Screws
20	923-0510	1	Spinner Rear Transfer Shaft (720)
	923-0512	1	Spinner Rear Transfer Shaft (865)
21	901-0561-2	2	Spinner Poly Liner
22	901-0783	2	Seal Plate
23	901-0558-6	2	Top Spinner Tooth Only
	881-6311-1.75Z	4	5/8-11 x 1-3/4" Machine Bolt
	886-6311-Z	4	5/8-11 Center Lock Nut
24	901-0562-1-6	2	Spinner Shaft Sleeve (Welded On)
25	111-0060-18-CC	3	Coupling Chain With Connector Pin & Snap Plate
26	933-0507	2	1-3/4" Shaft Lock Collar
27	914-3832-NG	2	Backside Bearing Seal
28	Bearing Cover Weldment	2	2-1/8" O-Ring
29	901-0843	2	Bearing Cover Weldment

CORNER GEARBOX

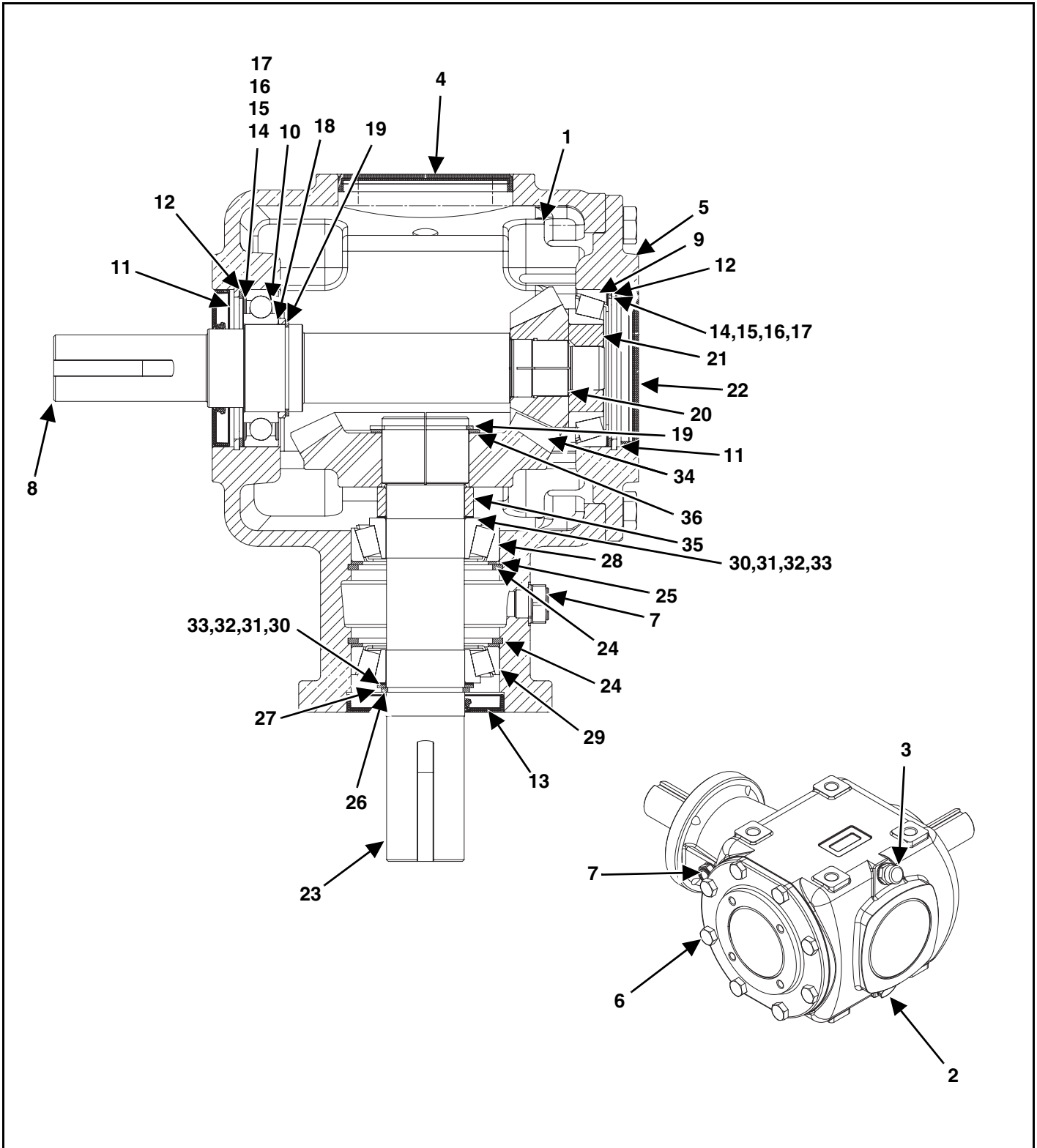

KEY	PART NUMBER	QTY	DESCRIPTION
0	19-0063	1	Benzi Corner Gearbox
1	119-B-104	1	Case
2	119-B-02	2	Plug
3	119-B-03	1	Breather Plug
4	119-B-04	11	Rubber Cup
5	119-B-05	1	Cover
6	119-B-06	8	M12 x 30 Bolt
7	119-B-58	1	Sight Glass Level Indicator
8	119-B-37	1	Shaft
9	119-B-11	1	Roller Bearing
10	119-B-19	1	Deep Groove Ball Bearing
11	119-B-17	2	Retaining Ring
12	119-B-16	2	Support Washer
13	119-B-86	2	Oil Seal
14	119-B-13	2	Shim Washer
15	119-B-12	2	Shim Washer
16	119-B-14	2	Shim Washer
17	119-B-15	2	Shim Washer
18	119-B-42	1	Spacer
19	119-B-43	2	Retaining Ring
20	119-B-44	1	Bevel Gear
21	119-B-45	1	Ring For Shrink Fit
22	119-B-39	1	Rubber Cap
23	119-B-40	1	Pinion Shaft
24	119-B-32	2	Retaining Ring
25	119-B-31	2	Support Washer
26	119-B-33	1	Retaining Ring
27	119-B-34	1	Washer
28	119-B-30	1	Tapered Roller Bearing
29	119-B-35	1	Tapered Roller Bearing
30	119-B-27	2	Shim Washer
31	119-B-26	2	Shim Washer
32	119-B-28	2	Shim Washer
33	119-B-29	2	Shim Washer
34	119-B-38	1	Bevel Gear
35	119-B-103	1	Spacer
36	119-B-47	1	Support Washer

RIGHT SPINNER GEARBOX

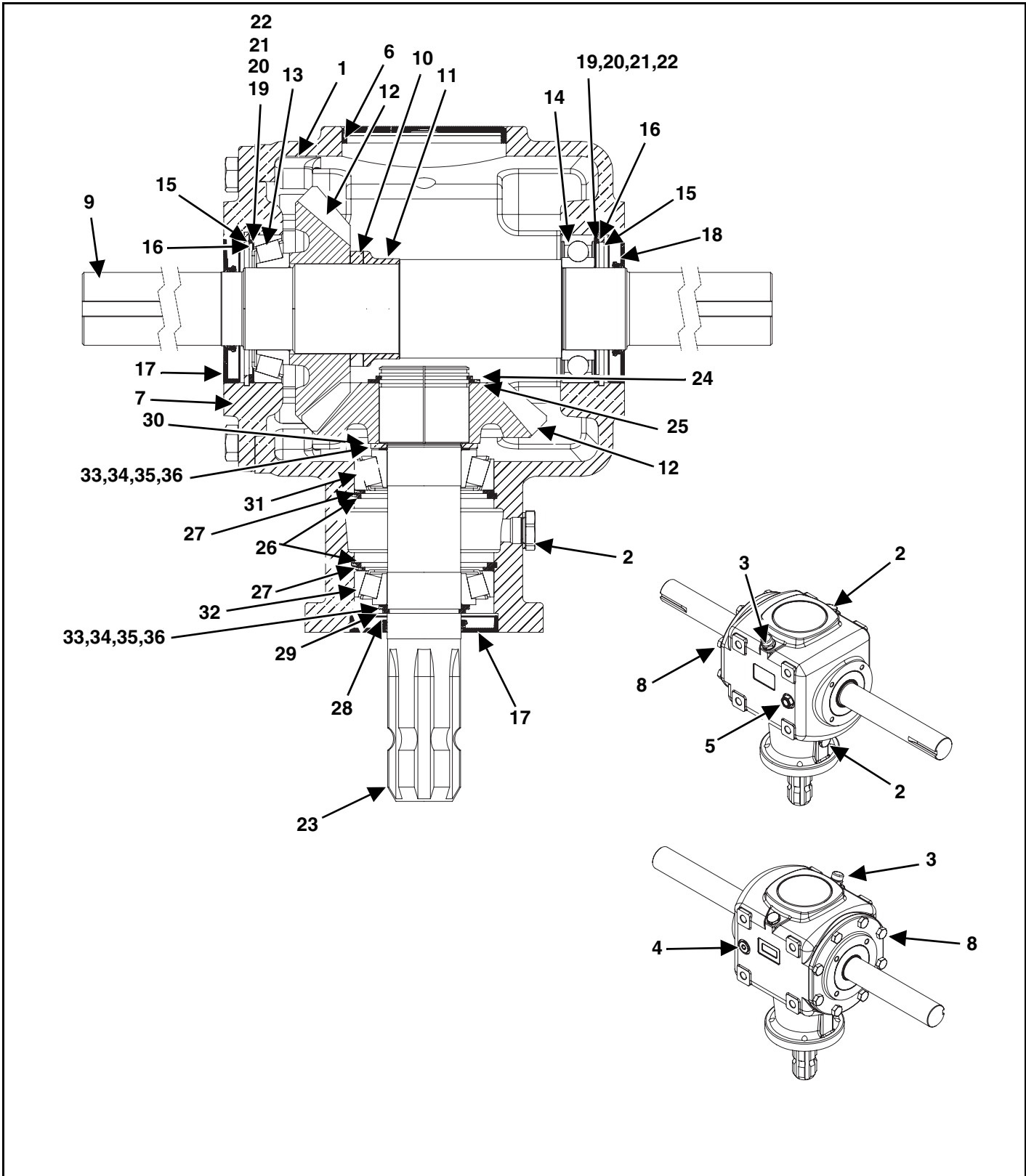

KEY	PART NUMBER	QTY	DESCRIPTION
0	19-0065	1	Benzi Right Spinner Gearbox
1	1119-B-48	1	Case
2	119-B-02	1	Plug
3	119-B-03	1	Breather Plug
4	119-B-105	1	Drain Plug
5	119-B-58	1	Sight Glass Level Indicator
6	119-B-04	1	Rubber Cup
7	119-B-05	1	Cover
8	119-B-06	8	M12 x 30 Bolt
9	119-B-53	1	Shaft
10	119-B-09	1	Spacer
11	119-B-08	1	Spacer
12	119-B-49	2	Bevel Gear
13	119-B-11	1	Tapered Roller Bearing
14	119-B-19	1	Deep Groove Ball Bearing
15	119-B-17	2	Retaining Ring
16	119-B-16	2	Support Washer
17	119-B-86	2	Oil Seal
18	119-B-54	1	Oil Seal
19	119-B-13	2	Shim Washer
20	119-B-12	2	Shim Washer
21	119-B-14	2	Shim Washer
22	119-B-15	2	Shim Washer
23	119-B-5	1	Shaft
24	119-B-22	1	Retaining Ring
25	119-B-23	1	Support Washer
26	119-B-32	2	Retaining Ring
27	119-B-31	2	Support Washer
28	119-B-33	1	Retaining Ring
29	119-B-34	1	Support Washer
30	119-B-25	1	Spacer
31	119-B-30	1	Tapered Roller Bearing
32	119-B-35	1	Tapered Roller Bearing
33	119-B-27	2	Shim Washer
34	119-B-26	2	Shim Washer
35	119-B-28	2	Shim Washer
36	119-B-29	2	Shim Washer

LEFT SPINNER GEARBOX

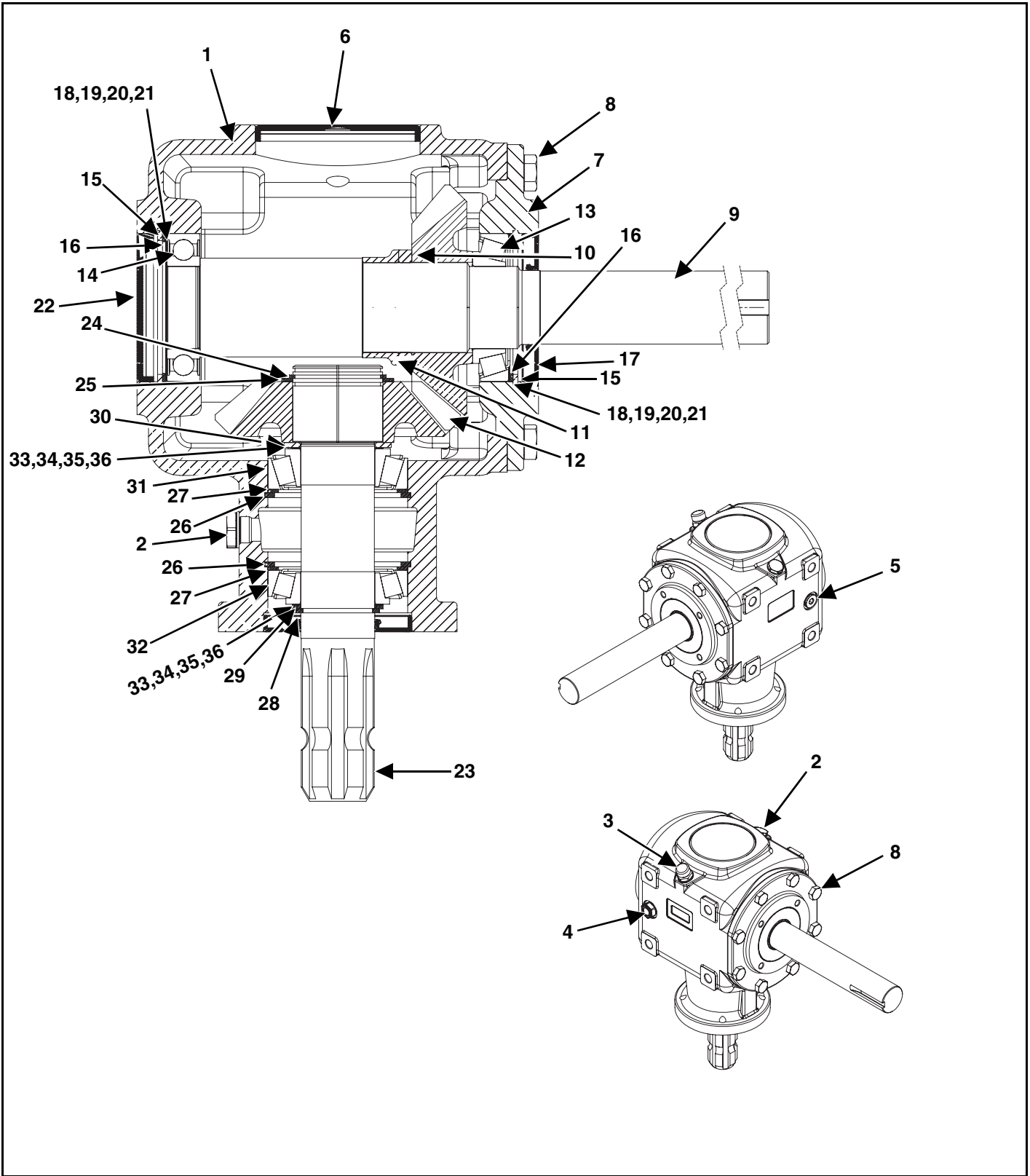

KEY	PART NUMBER	QTY	DESCRIPTION
0	19-0064	1	Benzi Left Spinner Gearbox
1	119-B-48	1	Case
2	119-B-02	2	Plug
3	119-B-03	1	Breather Plug
4	119-B-58	1	Sight Glass Level Indicator
5	119-B-105	1	Drain Plug
6	119-B-04	1	Rubber Cup
7	119-B-05	1	Cover
8	119-B-06	8	M12 x 30 Bolt
9	119-B-50	1	Shaft
10	119-B-09	1	Spacer
11	119-B-08	1	Spacer
12	119-B-49	2	Bevel Gear
13	119-B-11	1	Tapered Roller Bearing
14	119-B-19	1	Deep Grove Ball Bearing
15	119-B-17	2	Retaining Ring
16	119-B-16	2	Support Washer
17	119-B-86	2	Oil Seal
18	119-B-13	2	Shim Washer
19	119-B-12	2	Shim Washer
20	119-B-14	2	Shim Washer
21	119-B-15	2	Shim Washer
22	119-B-39	1	Rubber Cap
23	119-B-51	1	Shaft
24	119-B-22	1	Retaining Ring
25	119-B-23	1	Support Washer
26	119-B-32	2	Retaining Ring
27	119-B-31	2	Support Washer
28	119-B-33	1	Retaining Ring
29	119-B-34	1	Support Washer
30	119-B-25	1	Spacer
31	119-B-30	1	Tapered Roller Bearing
32	119-B-35	1	Tapered Roller Bearing
33	119-B-27	2	Shim Washer
34	119-B-26	2	Shim Washer
35	119-B-28	2	Shim Washer
36	119-B-29	2	Shim Washer

SPINDLES & O-BEAMS

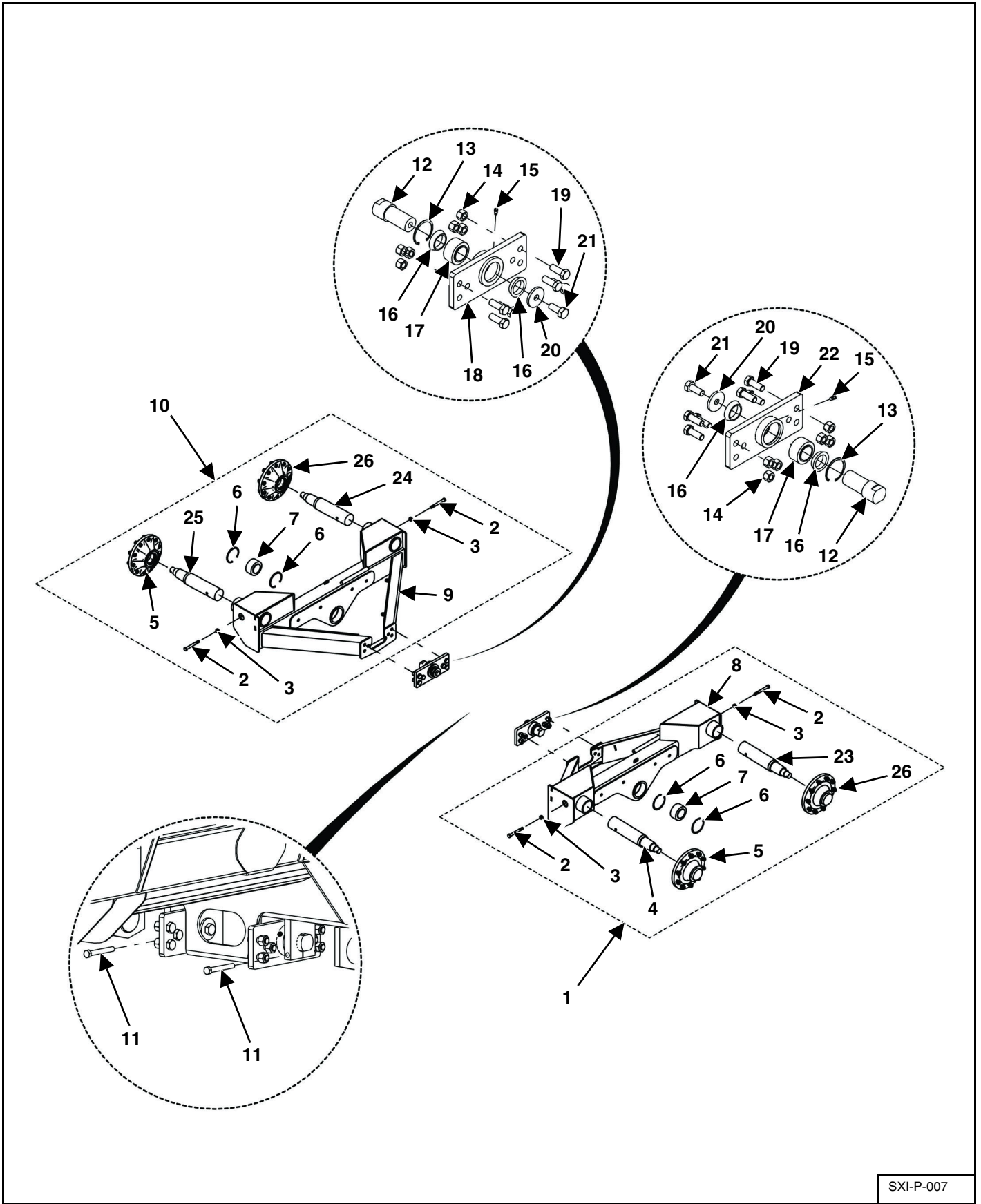

SXI-P-007

KEY	PART NUMBER	QTY	DESCRIPTION
1	901-0514	1	Left O-Beam Assembly (Standard 720) (Includes Key #'s 13, 17, & 22)
	901-0514-NH	1	Left O-Beam Assembly Without Hubs (Standard 720) (Includes Key #'s 13, 17, & 22)
	901-0514-NHS	1	Left O-Beam Assembly Without Hubs & Spindles (Standard 720) (Includes Key #'s 13, 17, & 22)
	901-0503	1	Left O-Beam Assembly (Hi-Float Package) (Standard 865) (Optional 720) (Includes Key #'s 13, 17, & 22)
	901-0503-NH	1	Left O-Beam Assembly Without Hubs (Hi-Float Package) (Standard 865) (Optional 720) (Includes Key #'s 13, 17, & 22)
	901-0503-NHS	1	Left O-Beam Assembly Without Hubs & Spindles (Hi-Float Package) (Standard 865)(Optional 720) (Includes Key #'s 13, 17, & 22)
	901-0572	1	Left O-Beam Assembly (720 With Scales Only) (Includes Key #'s 13, 17, & 22)
	901-0572-NH	1	Left O-Beam Assembly Without Hubs (720 With Scales Only) (Includes Key #'s 13, 17, & 22)
	901-0572-NHS	1	Left O-Beam Assembly Without Hubs & Spindles (720 With Scales Only) (Includes Key #'s 13, 17, & 22)
	901-0704	1	Left O-Beam Assembly (720 With Brakes Only) (Includes Key #'s 13, 17, & 22)
	901-0704-NH	1	Left O-Beam Assembly Without Hubs (720 With Brakes Only) (Includes Key #'s 13, 17, & 22)
	901-0704-NHS	1	Left O-Beam Assembly Without Hubs & Spindles (720 With Brakes Only) (Includes Key #'s 13, 17, & 22)
	901-0647	1	Left O-Beam Assembly (865 With Scales Only) (Includes Key #'s 13, 17, & 22)
	901-0647-NH	1	Left O-Beam Assembly Without Hubs (865 With Scales Only) (Includes Key #'s 13, 17, & 22)
	901-0647-NHS	1	Left O-Beam Assembly Without Hubs & Spindles (865 With Scales Only) (Includes Key #'s 13, 17, & 22)
	901-0604	1	Left O-Beam Assembly (865 With 2 Brake System Only) (Includes Key #'s 13, 17, & 22)
	901-0604-NHS	1	Left O-Beam Assembly Without One Hub & One Spindle (865 With 2 Brake System Only) (Includes Key #'s 13, 17, & 22)
901-0606	1	Left O-Beam Assembly (865 With 4 Brake System Only) (Includes Key #'s 13, 17, & 22)	
2	851-7510-5.5Z	4	3/4-10 x 5-1/2" Machine Bolt (Standard 720) (720 With Scales)
	851-7510-6.5Z	4	3/4-10 x 6-1/2" Machine Bolt (Hi-Float Package) (Standard 865) (Optional 720) (865 With 2/4 Brake System)
3	815-7510-Z	4	3/4-10 Nylon Insert Lock Nut (Standard 720) (720 With Scales)
	814-7510-Z	4	3/4-10 Indented Lock Nut (Hi-Float Package) (Standard 865) (Optional 720) (865 With 2/4 Brake System)
4	75-0111-3	1	O-Beam Spindle (Standard 720)
	75-0118	1	O-Beam Spindle (Hi-Float Package) (Standard 865) (Optional 720) (865 With 2 Brake System)
	901-0704-2-AS	1	O-Beam Spindle (720 With 4 Brake System)
	See Page 106	1	O-Beam Weigh Bar Spindle (720/865 With Scales)
		1	Refer to Key #8 (865 4 Brake System)
5	See Page 84	2	Hub (Standard 720) (720 With Brakes) (720 With Scales)
	See Page 84	2	Hub (Hi-Float Package) (Standard 865) (Optional 720) (865 With 2 Brake System) (865 With Scales)
	975-0200	2	Hub (865 With 4 Brake System)
6	33-0057	4	Internal Snap Ring (Standard 720) (720 With Brakes) (720 With Scales)
	33-0058	4	Internal Snap Ring (Hi-Float Package) (Standard 865) (Optional 720) (865 With 2/4 Brake System)

SPINDLES & O-BEAMS (CONT'D)

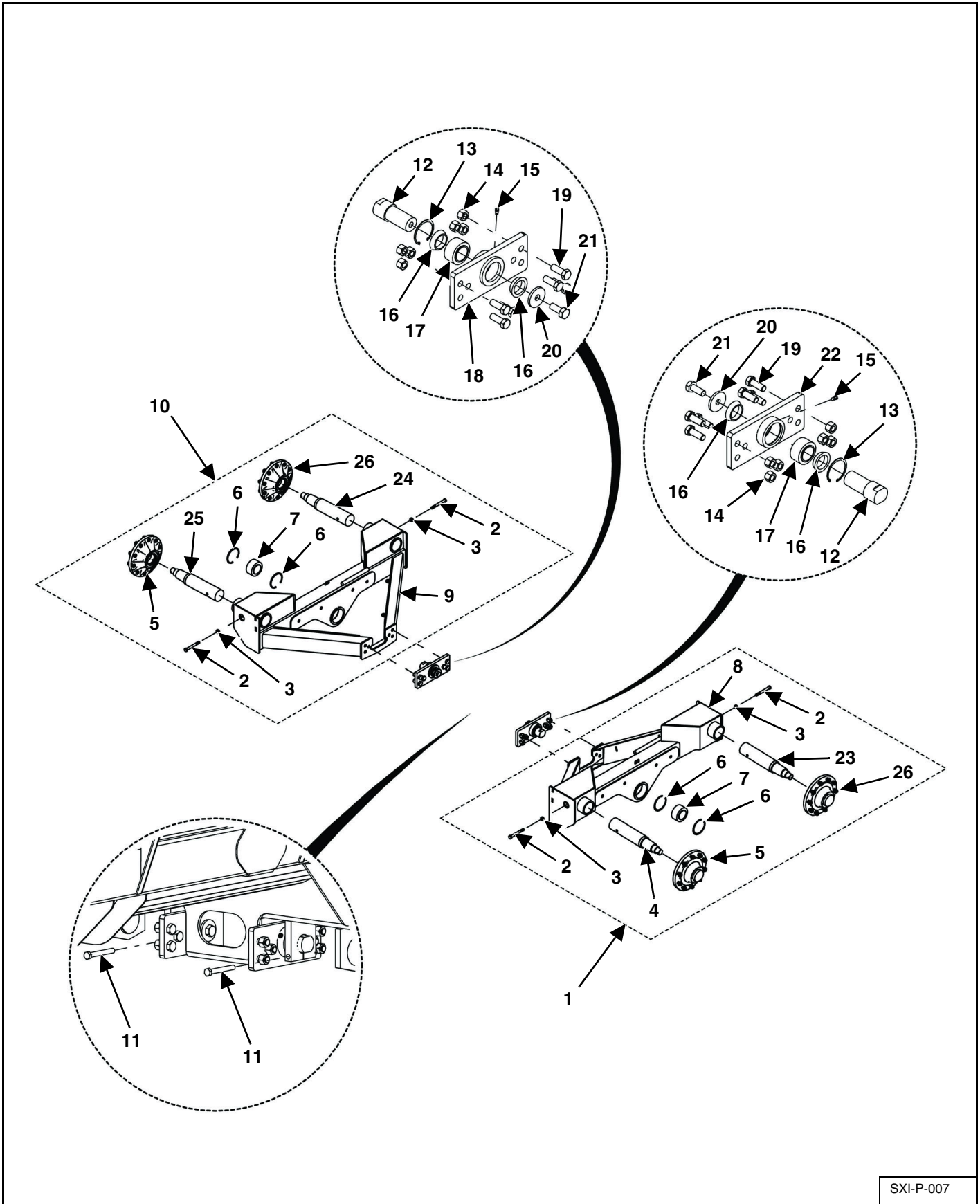

SXI-P-007

KEY	PART NUMBER	QTY	DESCRIPTION
7	914-3822	2	Sealed Spherical Bearing (Standard 720) (720 With Brakes) (720 With Scales)
	114-VM-0003	2	Sealed Spherical Bearing (Hi-Float Package) (Standard 865) (Optional 720) (865 With 2/4 Brake System)
8	901-0514-1	1	Left O-Beam Weldment (Standard 720)
	901-0503-1	1	Left O-Beam Weldment (Hi-Float Package) (Standard 865) (Optional 720)
	901-0572-1	1	Left O-Beam Weldment (720 With Scales Only)
	901-0704-1	1	Left O-Beam Weldment (720 With 4 Brake System)
	901-0647-1	1	Left O-Beam Weldment (865 With Scales Only)
	901-0604-1	1	Left O-Beam Weldment (865 With 2 Brake System Only)
	901-0606-1	1	Left O-Beam Weldment (865 With 4 Brake System Only)
9	901-0513-1	1	Right O-Beam Weldment (Standard 720)
	901-0502-1	1	Right O-Beam Weldment (Hi-Float Package) (Standard 865) (Optional 720)
	901-0573-1	1	Right O-Beam Weldment (720 With Scales Only)
	901-0705-1	1	Right O-Beam Weldment (720 With 4 Brake System)
	901-0646-1	1	Right O-Beam Weldment (865 With Scales Only)
	901-0605-1	1	Right O-Beam Weldment (865 With 2 Brake System Only)
	901-0607-1	1	Right O-Beam Weldment (865 With 4 Brake System Only)
10	901-0513	1	Right O-Beam Assembly (Standard 720) (Includes Key #'s 13, 17, & 18)
	901-0513-NH	1	Right O-Beam Assembly Without Hubs (Standard 720) (Includes Key #'s 13, 17, & 18)
	901-0513-NHS	1	Right O-Beam Assembly Without Hubs & Spindles (Standard 720) (Includes Key #'s 13, 17, & 18)
	901-0502	1	Right O-Beam Assembly (Hi-Float Package) (Standard 865) (Optional 720) (Includes Key #'s 13, 17, & 18)
	901-0502-NH	1	Right O-Beam Assembly Without Hubs (Hi-Float Package) (Standard 865) (Optional 720) (Includes Key #'s 13, 17, & 18)
	901-0502-NHS	1	Right O-Beam Assembly Without Hubs & Spindles (Hi-Float Package) (Standard 865) (Optional 720) (Includes Key #'s 13, 17, & 18)
	901-0573	1	Right O-Beam Assembly (720 With Scales Only) (Includes Key #'s 13, 17, & 18)
	901-0573-NH	1	Right O-Beam Assembly Without Hubs (720 With Scales Only) (Includes Key #'s 13, 17, & 18)
	901-0573-NHS	1	Right O-Beam Assembly Without Hubs & Spindles (720 With Scales Only) (Includes Key #'s 13, 17, & 18)
	901-0705	1	Right O-Beam Assembly (720 With Brakes Only) (Includes Key #'s 13, 17, & 18)
	901-0705-NH	1	Right O-Beam Assembly Without Hubs (720 With Brakes Only) (Includes Key #'s 13, 17, & 18)
	901-0705-NHS	1	Right O-Beam Assembly Without Hubs & Spindles (720 With Brakes Only) (Includes Key #'s 13, 17, & 18)
	901-0646	1	Right O-Beam Assembly (865 With Scales Only) (Includes Key #'s 13, 17, & 18)
	901-0646-NH	1	Right O-Beam Assembly Without Hubs (865 With Scales Only) (Includes Key #'s 13, 17, & 18)
	901-0646-NHS	1	Right O-Beam Assembly Without Hubs & Spindles (865 With Scales Only) (Includes Key #'s 13, 17, & 18)
	901-0605	1	Right O-Beam Assembly (865 With 2 Brake System Only) (Includes Key #'s 13, 17, & 18)
	901-0605-NHS	1	Right O-Beam Assembly Without One Hub & One Spindle (865 With 2 Brake System Only) (Includes Key #'s 13, 17, & 18)
901-0607	1	Right O-Beam Assembly (865 With 4 Brake System Only) (Includes Key #'s 13, 17, & 18)	

SPINDLES & O-BEAMS (CONT'D)

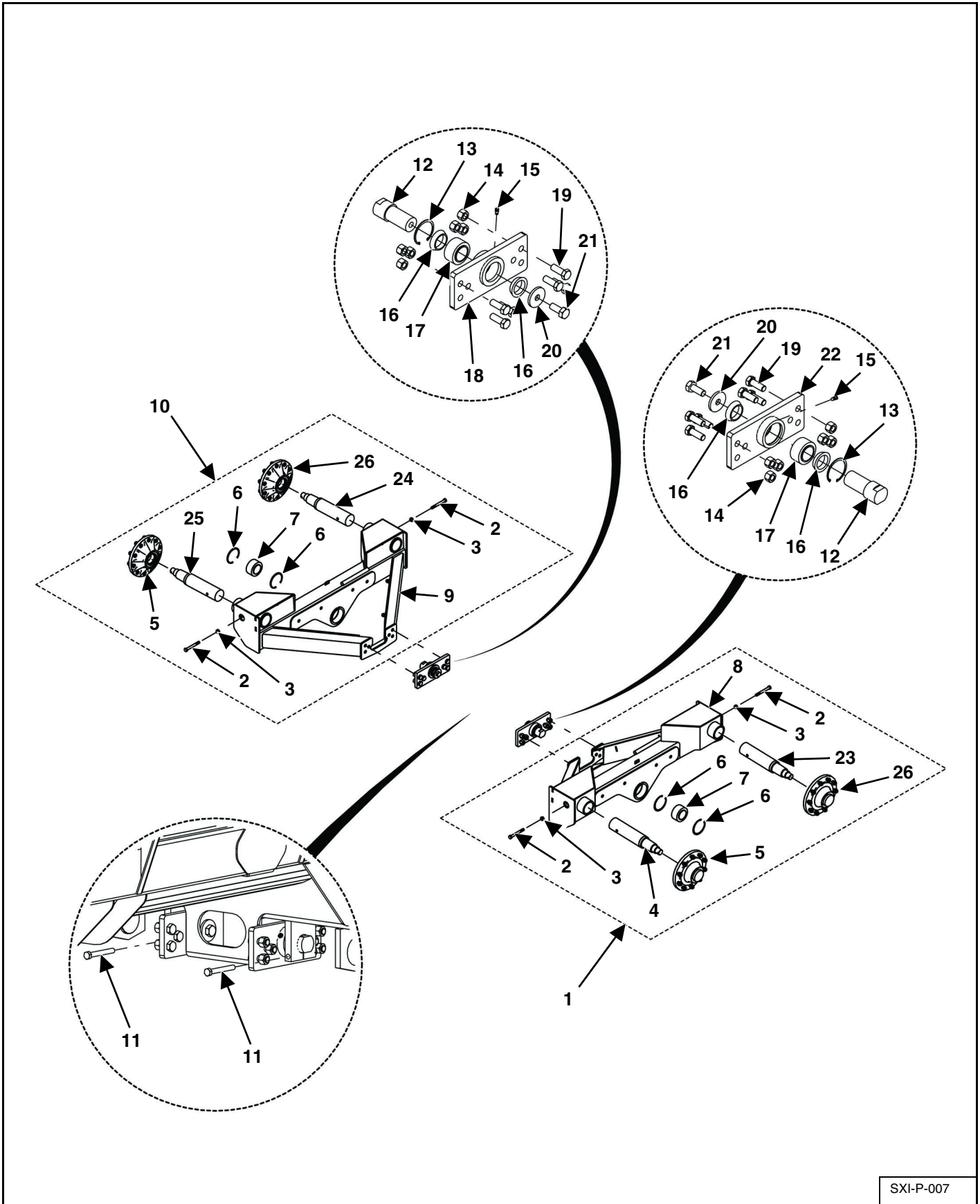

SXI-P-007

KEY	PART NUMBER	QTY	DESCRIPTION
11	881-7510-7Z	2	3/4-10 x 7" Hex Head Cap Screw
	885-7510-Z	2	3/4-10 Indented Lock Nut
12	M1-10-0004-1-2	2	O-Beam Inner Bearing Pin
13	33-0056	2	Internal Snap Ring
14	884-1008-Z	12	1-8 Top Lock Nut
15	930-3602	2	Brass Male Connector
16	M1-10-0004-1-1	4	O-Beam Inner Bearing Torque Collar
17	114-VM-0002	2	Plain Spherical Bearing
18	M1-12-0018-1	1	Left O-Beam Inner Bearing Weldment
19	851-1008-2.75Z	12	1-8 x 2-3/4" Hex Head Cap Screw
20	M1-10-0004-1-3	2	O-Beam Inner Bearing Washer
21	881-1014-2.5Z	2	1-14 x 2-1/2" Machine Bolt
22	M1-12-0017-1	1	Right O-Beam Inner Bearing Weldment
23	75-0111-3	1	O-Beam Spindle (Standard 720)
	75-0118	1	O-Beam Spindle (Hi-Float Package) (Standard 865)(Optional 720)
	901-0704-2-AS	1	O-Beam Spindle (720 With 4 Brake System)
	See Page 106	1	O-Beam Weigh Bar Spindle (720/865 With Scales)
		1	Refer to Key #8 (865 2/4 Brake System)
24	75-0111-3	1	O-Beam Spindle (Standard 720)
	75-0118	1	O-Beam Spindle (Hi-Float Package) (Standard 865) (Optional 720)
	901-0704-2-AS	1	O-Beam Spindle (720 With 4 Brake System)
	See Page 106	1	O-Beam Weigh Bar Spindle (720/865 With Scales)
		1	Refer to Key #9 (865 2/4 Brake System)
25	75-0111-3	1	O-Beam Spindle (Standard 720)
	75-0118	1	O-Beam Spindle (Hi-Float Package) (Standard 865)(Optional 720) (865 With 2 Brake System)
	901-0704-2-AS	1	O-Beam Spindle (720 With 4 Brake System)
	See Page 106	1	O-Beam Weigh Bar Spindle (720/865 With Scales)
		1	Refer to Key #9 (865 4 Brake System)
26	See Page 84	2	Hub (Standard 720) (720/865 With Scales)
	See Page 84	2	Hub (Hi-Float Package) (Standard 865) (Optional 720) (865 With Scales)
	975-0200	2	Hub (865 With 2/4 Brake System)

HUB ASSEMBLY

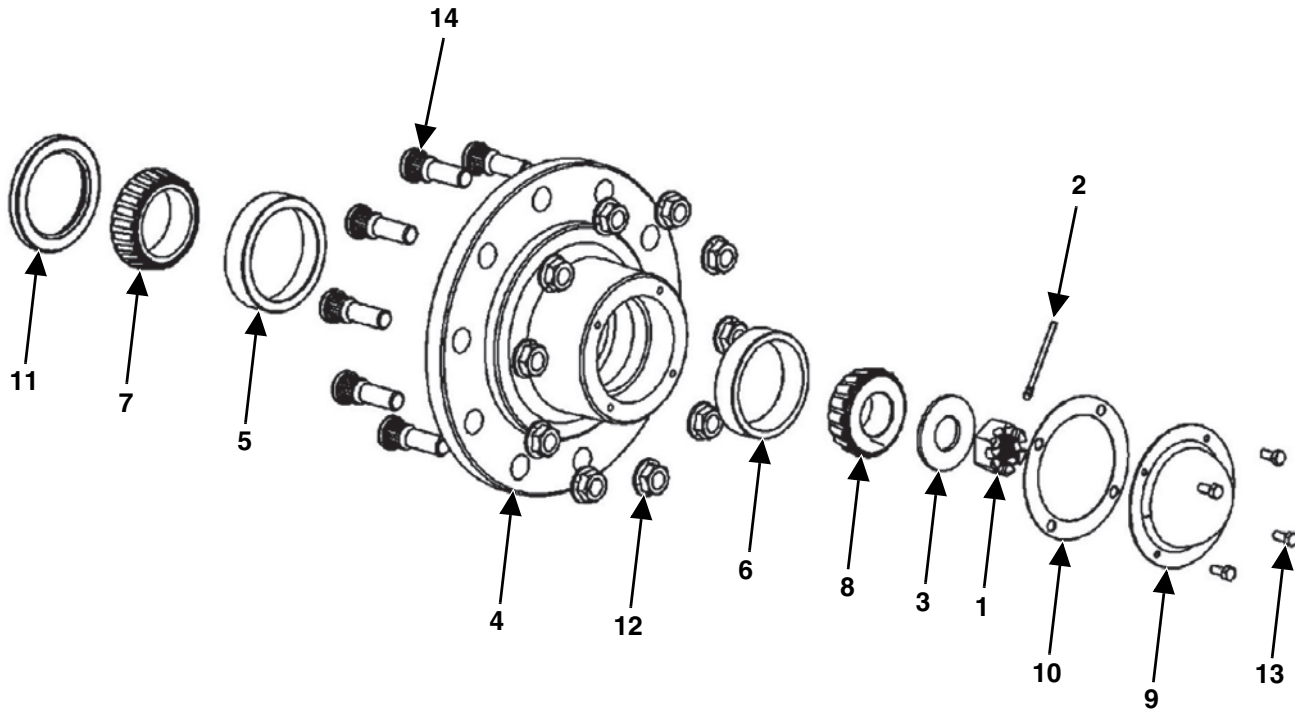

SXI-P-016

KEY	PART NUMBER	QTY	DESCRIPTION
0	75-0219	1	Hub Assembly (Standard 720) (720 With Brakes)
	75-0219-SC	1	Hub Assembly (720 With Scales)
	75-0213	1	Hub Assembly (Hi-Float Package) (Standard 865) (Optional 720)
	75-0213-SC	1	Hub Assembly (865 With Scales)
1	75-0208-8	1	Nut, Castle (Standard 720) (720 With Brakes) (720 With Scales)
	75-0213-13	1	Nut, Castle (Hi-Float Package) (Standard 865) (Optional 720)
2	75-0208-9	1	Cotter Pin (Standard 720) (720 With Brakes) (720 With Scales)
	75-0213-14	1	Cotter Pin (Hi-Float Package) (Standard 865) (Optional 720)
3	75-0208-7	1	Washer (Standard 720) (720 With Brakes) (720 With Scales)
	75-0213-12	1	Washer (Hi-Float Package) (Standard 865)(Optional 720)
4	75-0219-1	1	Hub With Bearing Races & Studs (Standard 720) (720 With Brakes) (720 With Scales)
	75-0213-1	1	Hub With Bearing Races & Studs (Hi-Float Package) (Standard 865)(Optional 720)
5	75-0211-4	1	Inner Wheel Race (Standard 720) (720 With Brakes) (720 With Scales)
	75-0213-10	1	Inner Wheel Race (Hi-Float Package) (Standard 865)(Optional 720)
6	75-0208-5	1	Outer Wheel Race (Standard 720) (720 With Brakes) (720 With Scales)
	75-0213-3	1	Outer Wheel Race (Hi-Float Package) (Standard 865) (Optional 720)
7	75-0211-3	1	Inner Wheel Bearing Cone (Standard 720) (720 With Brakes) (720 With Scales)
	75-0213-5	1	Inner Wheel Bearing Cone (Hi-Float Package) (Standard 865) (Optional 720)
8	75-0208-6	1	Outer Wheel Bearing Cone (Standard 720) (720 With Brakes) (720 With Scales)
	75-0213-6	1	Outer Wheel Bearing Cone (Hi-Float Package) (Standard 865) (Optional 720)
9	75-0219-3	1	Hub Cap (Standard 720) (720 With Brakes) (720 With Scales)
	75-0213-7	1	Hub Cap (Hi-Float Package) (Standard 865) (Optional 720)
10	75-0208-14	1	Hub Cap Gasket (Standard 720) (720 With Brakes) (720 With Scales)
	75-0213-11	1	Hub Cap Gasket (Hi-Float Package) (Standard 865) (Optional 720)
11	75-0211-2	1	Grease Seal (Standard 720) (720 With Brakes)
	75-0211-2-SC	1	Grease Seal (720 With Scales)
	75-0213-2	1	Grease Seal (Hi-Float Package) (Standard 865) (Optional 720)
	75-0213-2-SC	1	Grease Seal (865 With Scales)
12	75-0208-11	10	3/4"-16 Lug Nut-Flanged, Grade 8, Torque 378 ft/lbs
13	75-0208-13	4	Hex Bolt, 5/16"-18 x .75
14	75-0208-12	10	3/4"-16 Lug Bolt
NS	75-0219-4	11	Grease Zerk

FRONT GREASE HOSES

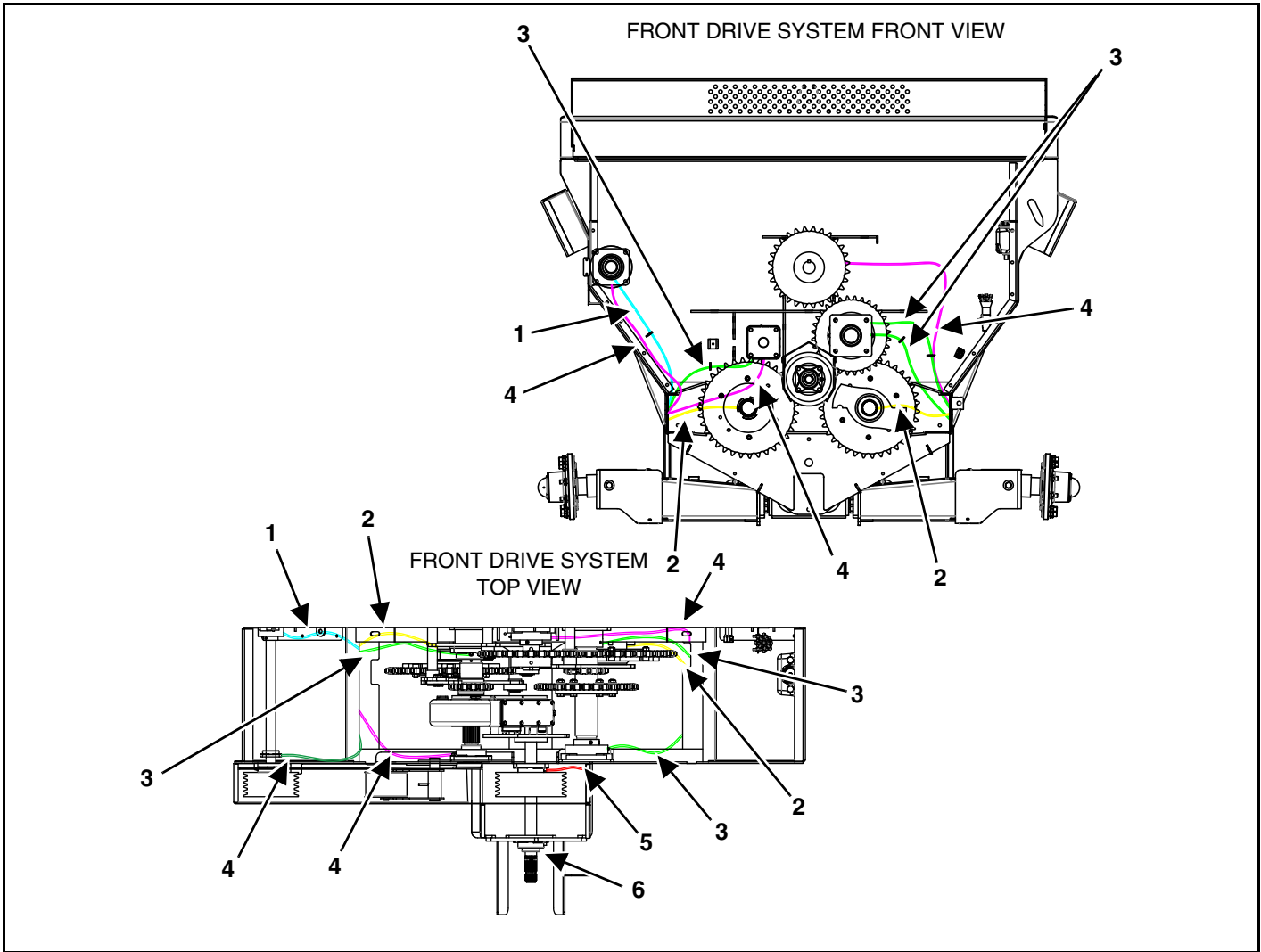

KEY	PART NUMBER	QTY	DESCRIPTION
1	155-02R7-35-1-1	1	1/8" x 35" Grease Hose
	155-2GK-NUT	1	Bulkhead Adapter Nut
	30-0001	1	1/4"-28 Straight Fitting
2	155-02R7-17-1-1	2	1/8" x 17" Grease Hose
	155-2GK-NUT	2	Bulkhead Adapter Nut
	30-0001	2	1/4"-28 Straight Fitting
3	155-02R7-28-1-1	3	1/8" x 28" Grease Hose
	155-2GK-NUT	3	Bulkhead Adapter Nut
	30-0001	3	1/4"-28 Straight Fitting
4	155-02R7-47-1-1	3	1/8" x 47" Grease Hose
	155-2GK-NUT	3	Bulkhead Adapter Nut
	30-0001	3	1/4"-28 Straight Fitting
5	155-02R7-10-1-1	1	1/8" x 10" Grease Hose
	155-2GK-NUT	1	Bulkhead Adapter Nut
	30-0001	1	1/4"-28 Straight Fitting
6	30-0023	1	1/8" NPT x 2-1/2" Nipple
	30-0009	1	1/8" NPT x 3/4" Coupler
	30-0002	1	1/8" NPT Straight Fitting

O-BEAMS & REAR GREASE HOSES

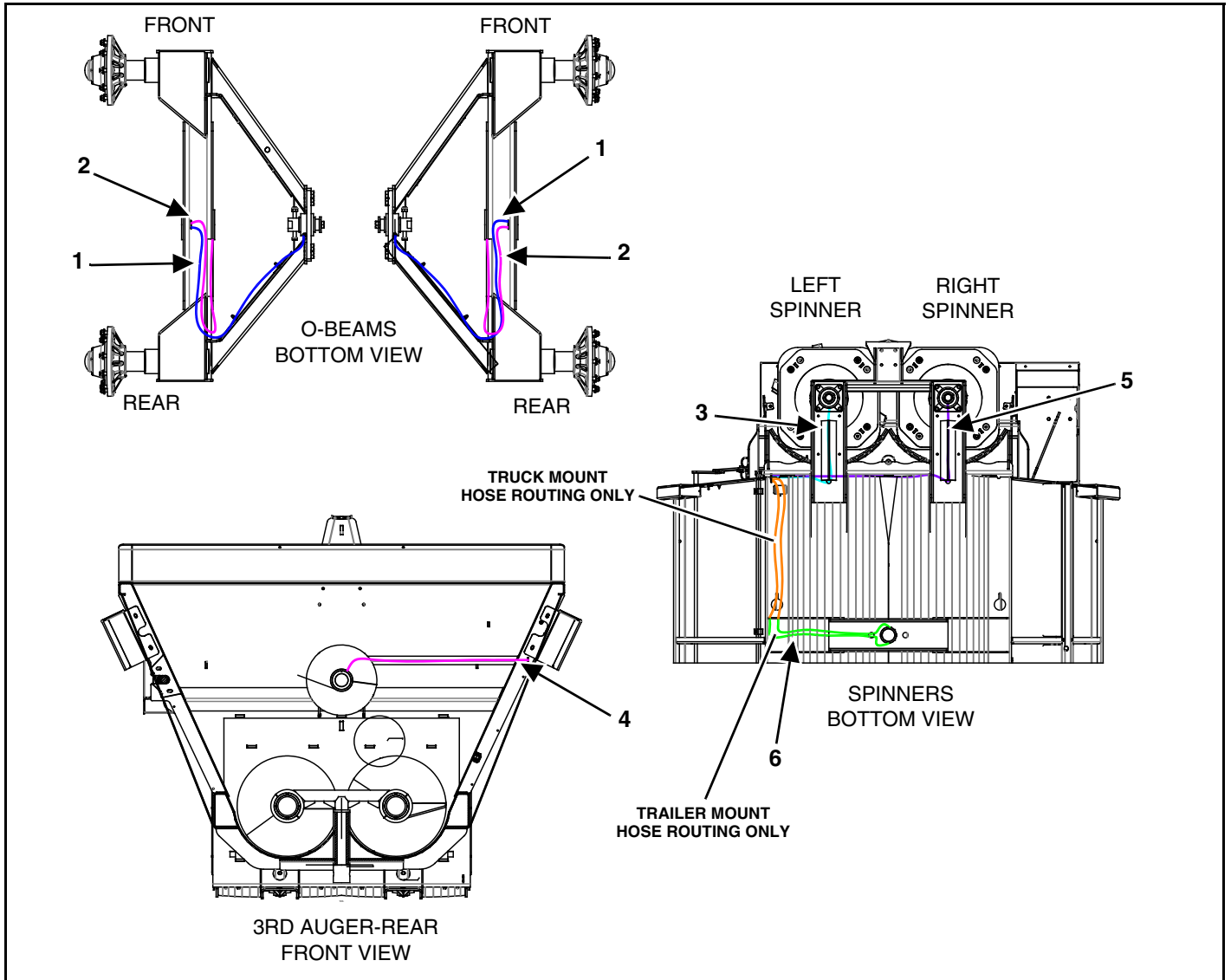

KEY	PART NUMBER	QTY	DESCRIPTION
1	155-02R7-59-1	2	O-Beam Inner Bearing 1/8" x 47" Grease Hose Assembly (720 Only)
	155-02R7-59-1	2	O-Beam Inner Bearing 1/8" x 59" Grease Hose Assembly (865 Only)
	30-0001	2	1/4"-28 Straight Fitting
2	155-02R7-47-1	2	O-Beam Outer Bearing 1/8" x 47" Grease Hose Assembly (865 Only)
	30-0001	2	1/4"-28 Straight Fitting (865 Only)
3	155-02R7-35-1	1	1/8" x 35" Grease Hose Assembly
	30-0001	1	1/4"-28 Straight Fitting
4	155-02R7-47-1	1	1/8" x 47" Grease Hose Assembly
	30-0003	1	1/4"-28 45 Degree Fitting
5	155-02R7-62-1	1	1/8" x 62" Grease Hose Assembly
	30-0001	1	1/4"-28 Straight Fitting
6	155-02R7-28-1	2	1/8" x 28" Grease Hose Assembly (Trailer Mount)
	155-02R7-75-1	2	1/8" x 75" Grease Hose Assembly (Truck Mount)
	30-0001	2	1/4"-28 Straight Fitting
	30-0020	2	1/8" NPT Street 90 Degree Fitting
NS	30-0019	2	O-Beam Outer Bearing 1/8" NPT x 2" Nipple (720 Only)
	30-0009	2	O-Beam Outer Bearing 1/8" NPT x 3/4" Coupler (720 Only)
	30-0006	2	O-Beam Outer Bearing 1/8" NPT 90 Degree Fitting (720 Only)

REAR GATE

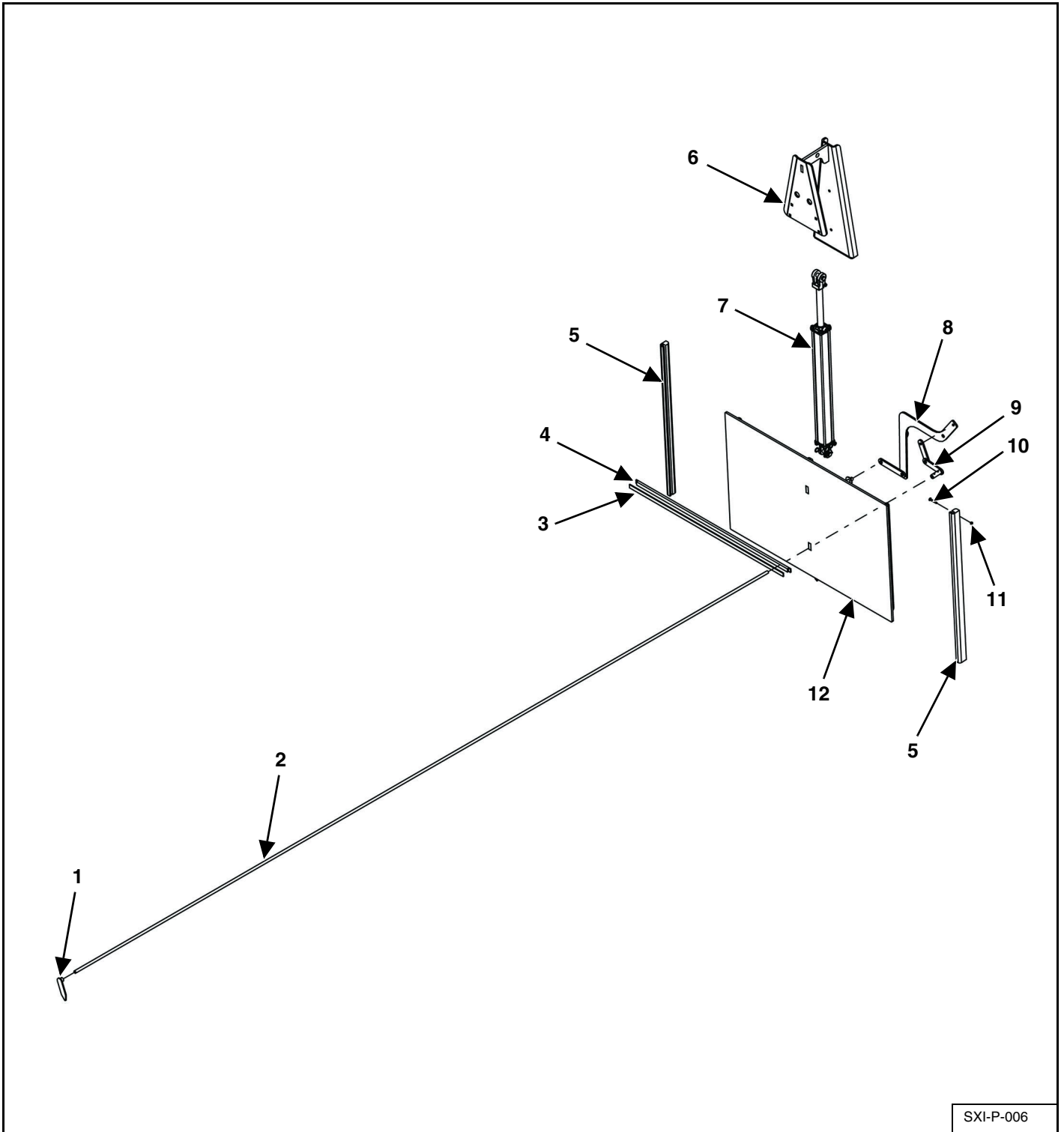

SXI-P-006

KEY	PART NUMBER	QTY	DESCRIPTION
1	925-0508	1	Gate Indicator Weldment
2	925-0519	1	Indicator Pipe (720)
	925-0510	1	Indicator Pipe (865)
3	901-0500-34	1	Gate Seal Spacer
4	949-3751	1	Gate Poly
5	949-0500	2	Poly Door Slides
6	925-0534	1	Gate Cylinder Mount Weldment
7	See Page 90	1	Gate Hydraulic Cylinder
8	925-0535	1	Gate Indicator Linkage Assembly
9	925-3767	1	Indicator Linkage Arm Weldment
10	850-3118-2.25Z	10	5/16-18 x 2-1/4" Carriage Bolt
11	814-3118-Z	10	5/16-18 Indented Lock Nut
12	901-0553	1	Gate Weldment

STANDARD HYDRAULICS

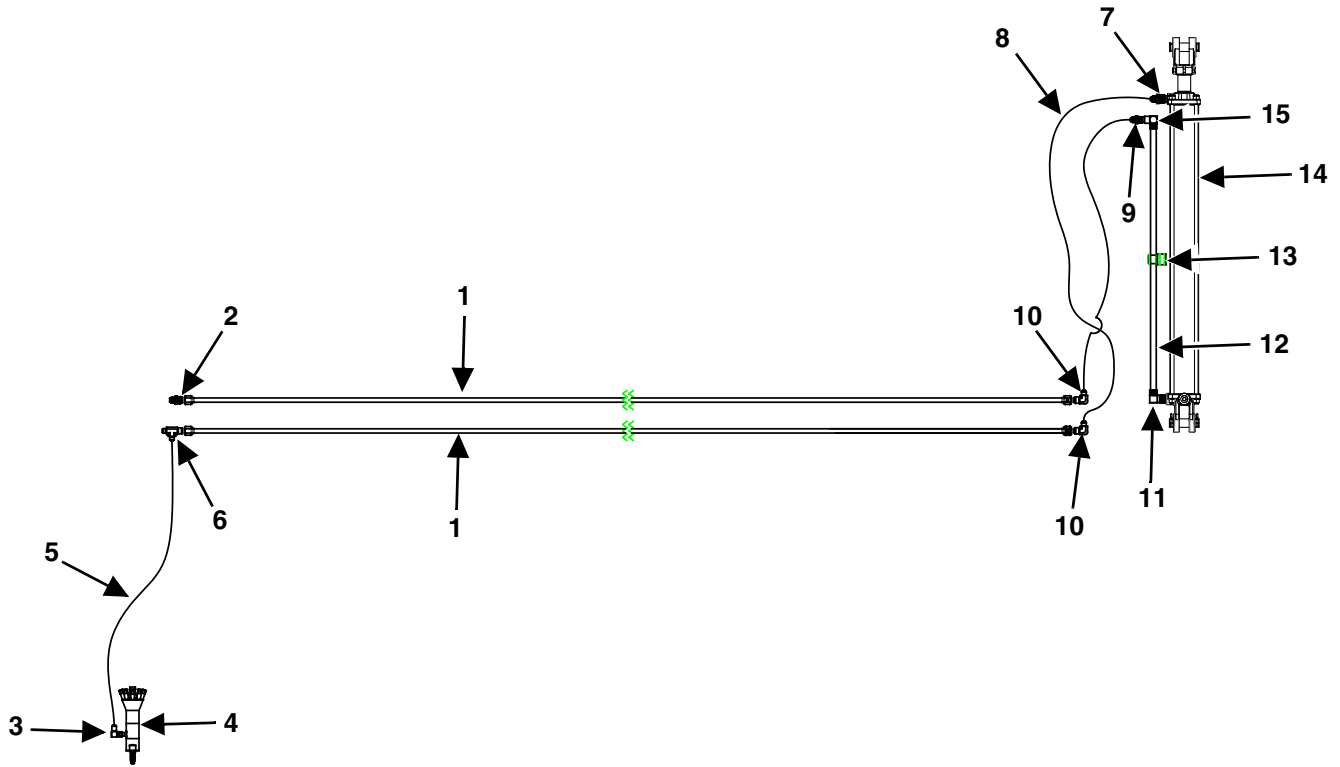

FRONT HOSES

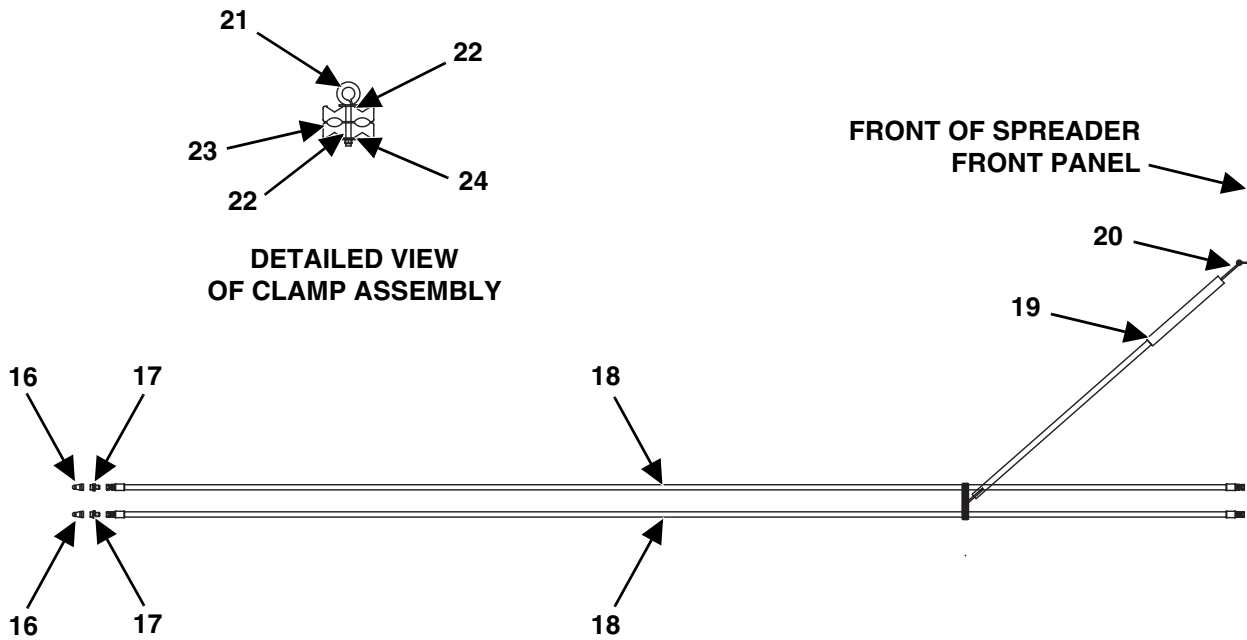

SXI-P-017

KEY	PART NUMBER	QTY	DESCRIPTION
1	55-0368	2	1/2" x 202" Hydraulic Pipe (720)
	55-0369	2	1/2" x 242" Hydraulic Pipe (865)
2	155-2403-08-06	1	Straight Union
3	155-6801-06-04	1	90 Degree Adjustable Elbow
4	See Page 92	1	Oiler Pump
5	155-04R17-19-1	1	1/4" x 19" Hose
6	155-2603-08-06-06	1	Tee
7	155-2404-06-08	1	Straight Adapter Union (Prior to SN SXI21720204)
	155-6400-6-8	1	Straight Adapter Union (SN SXI21720204 & Later)
8	155-06R17-70-1	2	3/8" x 70" Hose
9	155-2404-06-06	1	Straight Adapter Union
10	155-2500-08-06	2	90 Degree Elbow
11	55-0092	1	90 Degree Street Elbow (Prior to SN SXI21720204)
	955-0203	1	90 Degree Street Elbow (SN SXI21720204 & Later)
12	955-3753	1	Gate Cylinder Hydraulic Pipe
13	925-3754	1	Gate Cylinder Hydraulic Pipe Holder Weldment
14	955-0011-ASSY	1	Hydraulic Cylinder Assembly (Includes Key #'s 7, 9, 11, 12, 13, 14 & 15)
	955-0011-1	1	Baily Cylinder Seal Kit (Prior to SN SXI21720204)
	155-SK-4	1	Monarch Cylinder Seal Kit (SN SXI21720204 & Later)
15	955-3605	1	3/8" 90 Degree Elbow
16	155-8010-15	2	ORB Male Tip
17	155-6400-6-8	2	Straight Connector
18	155-06R17-178-1	2	3/8" x 178" Hose
19	29-0029	1	Hydraulic Hose Tender Spring Kit With Sleeve & Hardware
20	811-3118-1Z	1	5/16-18 x 1" Eyebolt
21	811-3118-2Z	1	5/16-18 x 2" Eyebolt
22	805-0031-Z	1	5/16" Flat Washer
23	55-0324	2	Twin Series Clamp
24	815-3118-Z	1	5/16-18 Nylon Lock Nut

OIL-KIT

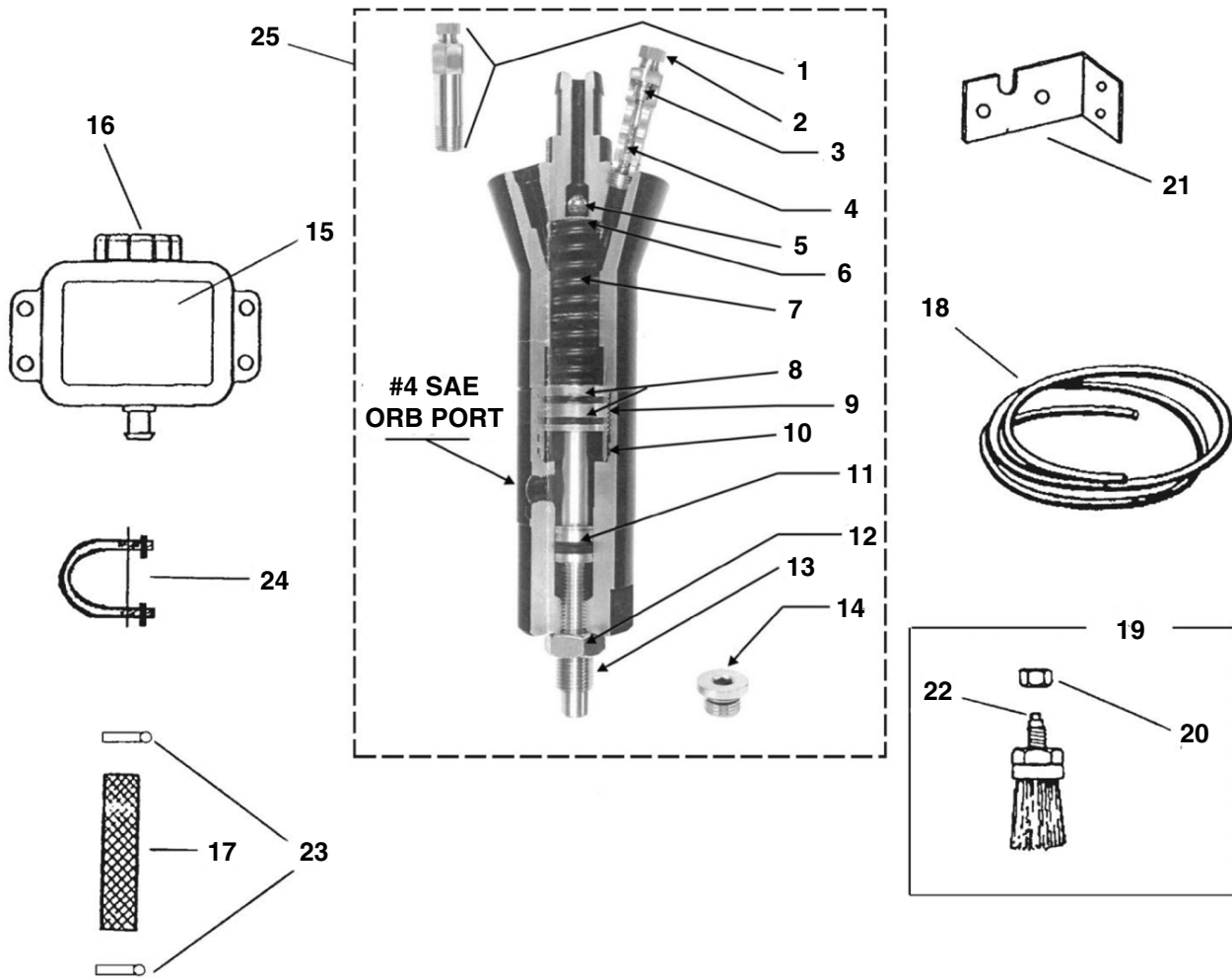

SXI-P-018

KEY	PART NUMBER	DESCRIPTION
1	952-0001-1-33	Holder, Manifold Valve Assembly
2	952-0001-1-27	Sleeve Nut Brass
3	952-0001-1-28	5/32" Brass Ferrule
4	952-0001-1-9	One Way Valve (Schrader Valve)
5	952-0001-1-11	Bearing, 7/16" Stainless
6	952-0001-1-10	Screen Flat Oiler .906 Diameter
7	952-0001-1-5	Spring, Oiler
8	952-0001-1-8	O Ring, Oiler Piston
9	952-0001-1-4	Piston, 2 Groove Alum, Short
10	952-0001-1-6	Washer, Rubber Lube Minder
11	952-0001-1-7	O Ring, Adjustable End Cap Plunger
12	952-0001-1-16	1/2-20 Jam Nut
13	952-0001-1-3	Plunger, Brass Adjustable End Cap
14	952-0001-1-32	1/8" Hex Head Pipe Plug
15	952-0001-1-18	Reservoir Two Quart Tank
16	952-0001-1-35	Reservoir Cap Only
17	952-0001-1-20	Tubing 5/8" ID Clear Polybraid
18	952-0001-1-21	Tubing 5/32" Nylon (Feet)
19	952-0001-1-25	Brush Assembly No 5/32" Insert
20	813-5020-Z	1/2-20 Plated Nut
21	952-0001-1-17	Bracket Oiler Mounting Pump
22	952-0001-1-14	5/32" Push In Insert (Nycoil)
23	952-0001-1-30	1" Hose Clamp
24	952-0001-1-31	U-Bolt Assembly # 9
25	952-0001-1-36	Oiler Body Pump Assembly, Complete

HIGHWAY LIGHTS

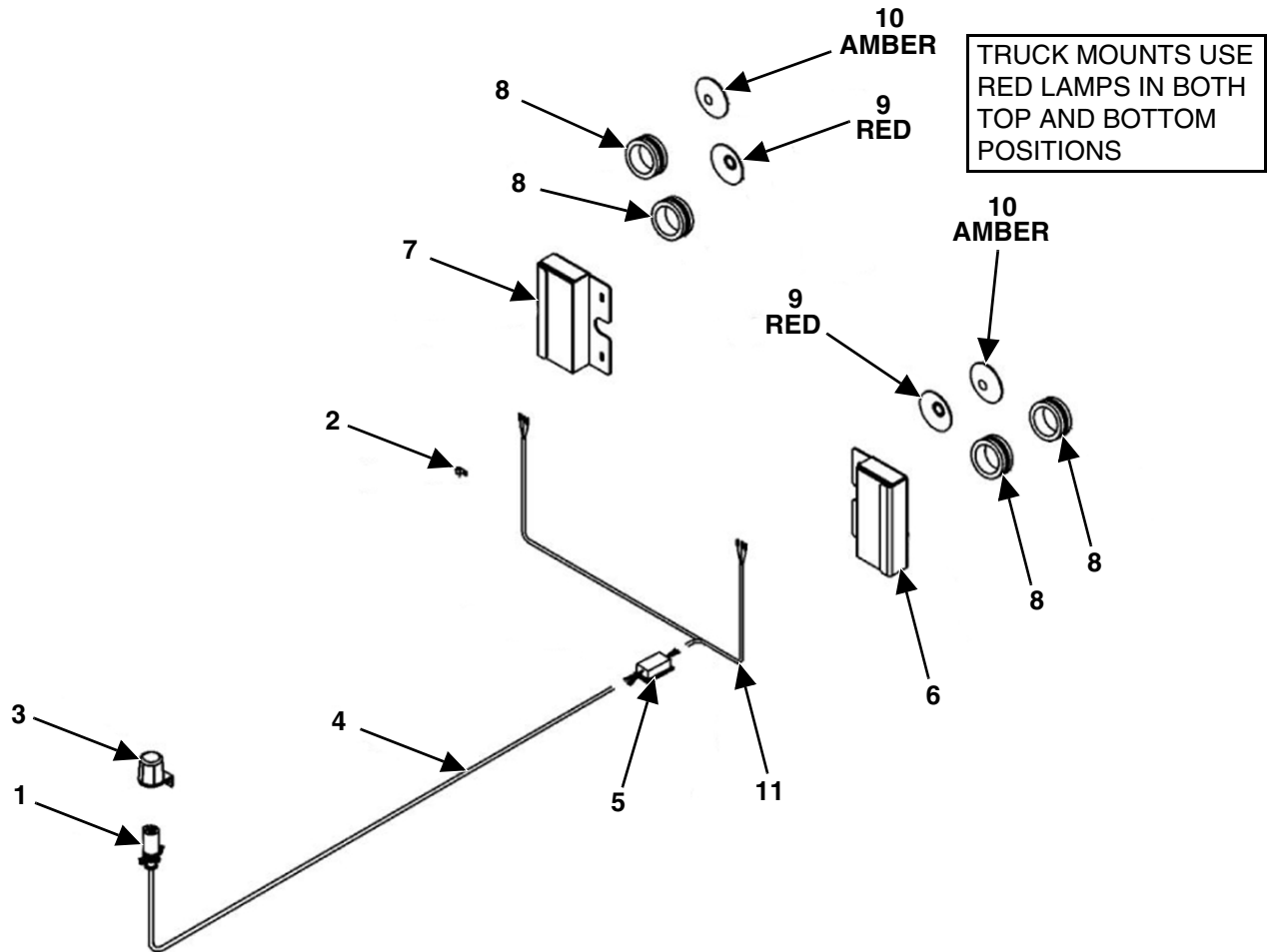

SXI-P-019

KEY	PART NUMBER	QTY	DESCRIPTION
1	56-0005-4	1	7-Contact Plug End Only, w/Spring
2	56-0008	1	Harness Frame Clip
3	56-0009	1	Stor-A-Way Plug Holder
4	56-0037	28.50	4 Conductor Trailer Cable (Per Foot) (720)
	56-0037	31.83	4 Conductor Trailer Cable (Per Foot) (865)
5	56-0084	1	LED Ag Enhancer Module
6	925-0011-1	1	LH LED Mount Bracket
7	925-0012-1	1	RH LED Mount Bracket
8	56-0092	4	4" Round Grommet
9	56-0090	2/4	4" Red Stop/Tail/Turn LED Lamp
10	56-0091	2/0	4" Amber Turn/Warning Lamp
11	56-0130	1	LED Light Y-Harness

TRUCK MOUNT BODY & SHIELDS

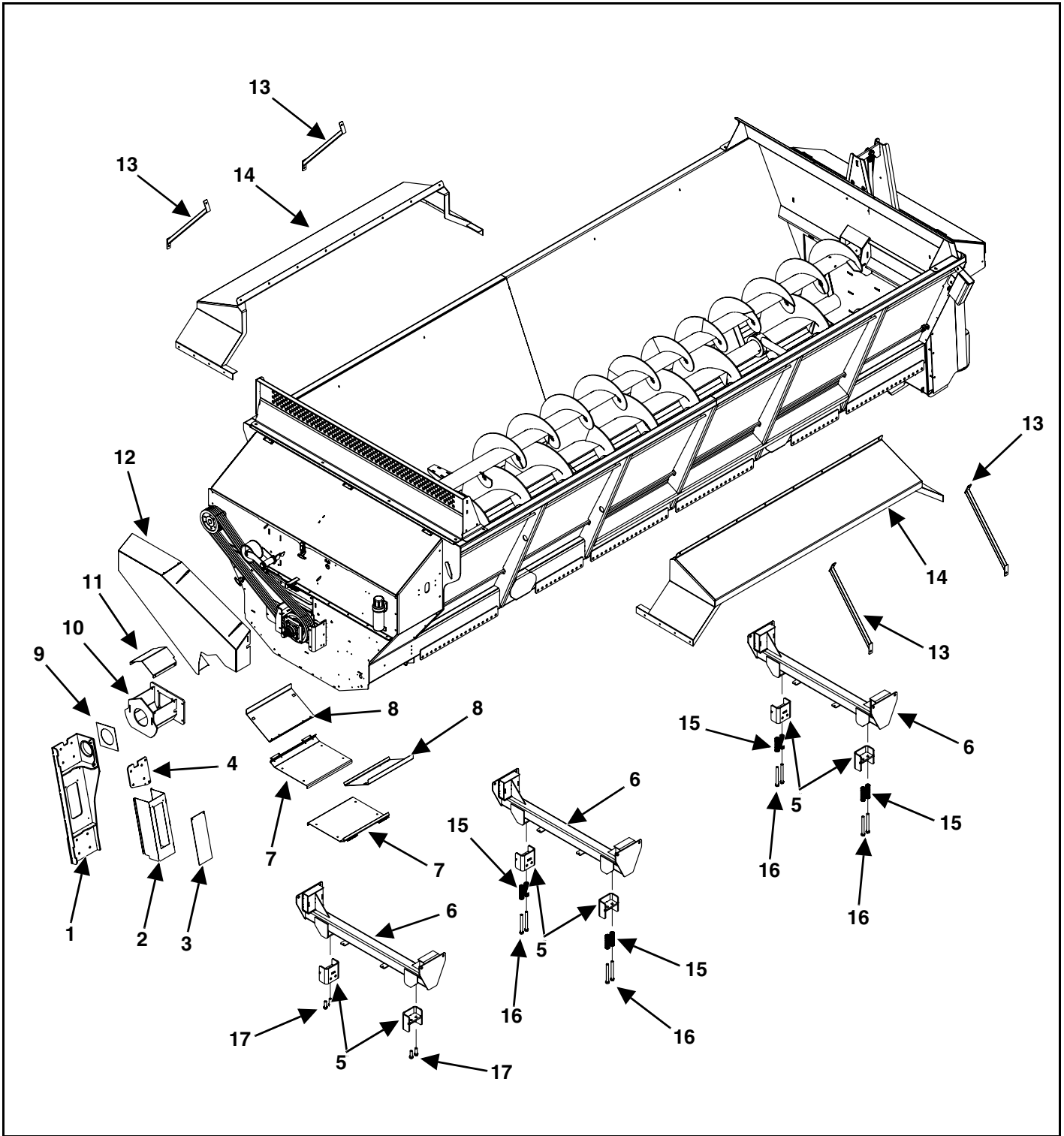

KEY	PART NUMBER	QTY	DESCRIPTION
1	925-0550	1	Gearbox Mount Weldment
2	924-0615	1	Driveline Shield Weldment
3	49-0515	1	Driveline Cover
4	925-0550-6	1	Gearbox Mount Plate
5	901-0733	6	Truck Frame Mount Bracket Weldment
6	901-0551	3	Mount Weldment
7	924-0528	2	Drive Shield Assembly
8	924-0529-1	2	Drive Shield
9	925-0550-8	1	Gearbox Mount Spacer
10	901-0732	1	Input Plate Weldment
11	924-0602	1	Input Shaft Cover
12	924-0614	1	Belt Drive Shield Weldment
13	901-0619	4	Fender Strut Weldment
14	901-0538	2	Truck Fender Weldment
15	929-0004	8	5" Die Spring
16	881-7516-7Z	8	3/4"-16 x 7" Hex Cap Screw
	884-7516-Z	8	3/4"-16 Top Lock Nut
17	881-7510-2.25Z	4	3/4"-10 x 2-1/4" Hex Cap Screw
	885-7510-Z	4	3/4"-10 Nylon Lock Nut

TRUCK MOUNT FRONT DRIVE

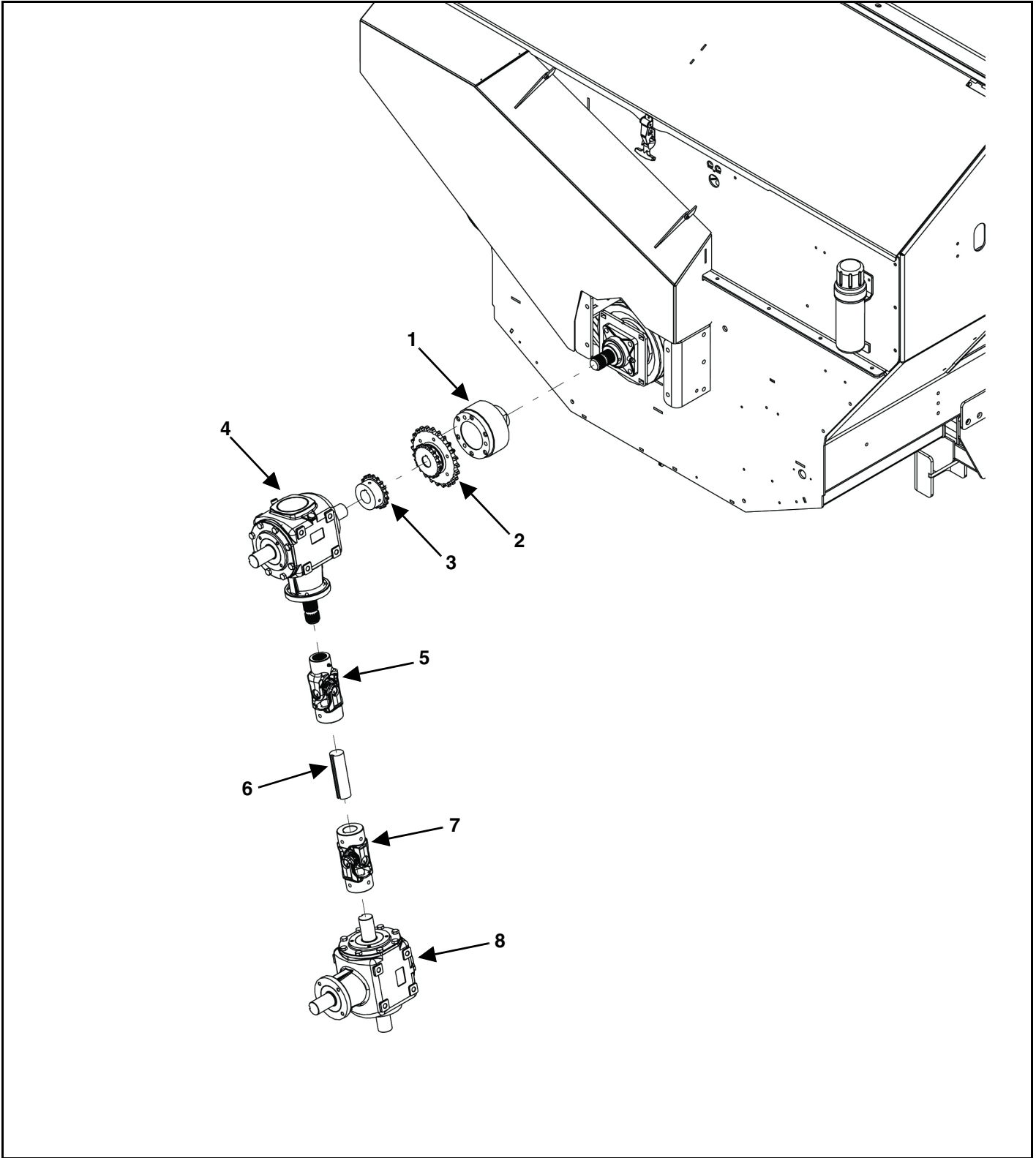

KEY	PART NUMBER	QTY	DESCRIPTION
1	See Page 104	1	Truck Mount Cut-Out Clutch
2	910-0098	1	Sprocket With Bolt Circle
3	937-0010-1	1	Coupler Sprocket, 1-3/4" Bore
4	See Page 100	1	Truck Mount Upper Gearbox
5	618-0005	1	Universal Coupler Joint
6	623-0020	1	Coupler Shaft
7	618-0002	1	Universal Coupler Joint
8	See Page 102	1	Truck Mount Lower Gearbox

TRUCK MOUNT UPPER GEARBOX

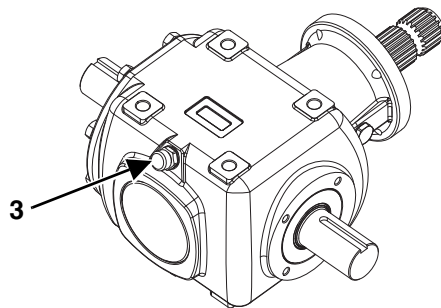
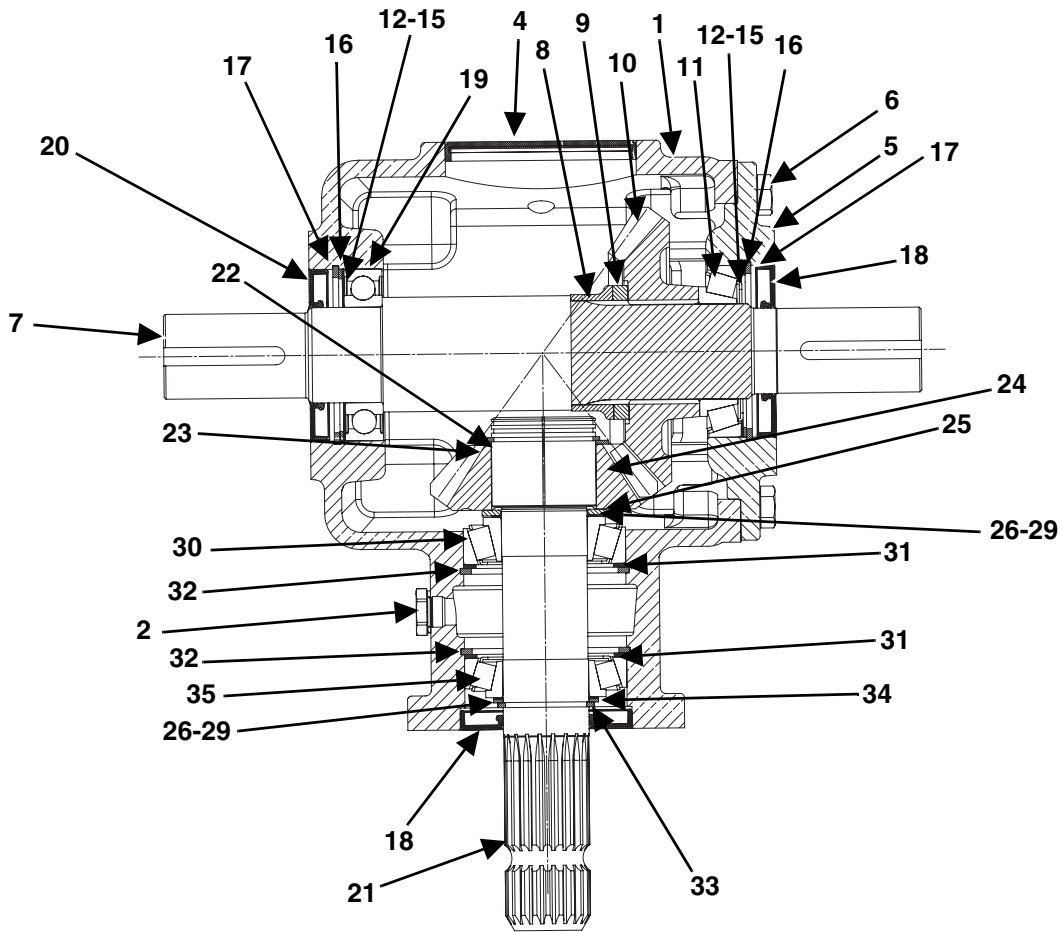

KEY	PART NUMBER	QTY	DESCRIPTION
0	119-R160-1.35-2	1	Gearbox
1	119-B-01	1	Casing
2	119-B-02	2	Oil Level / Drain Plug
3	119-B-03	1	Breather Plug
4	119-B-04	1	Cap
5	119-B-05	1	Top
6	119-B-06	8	M12-30 Bolt
7	119-B-07	1	Round Shaft
8	119-B-08	1	Spacer
9	119-B-09	1	Spacer
10	119-B-10	1	Bevel Gear
11	119-B-11	1	Taper Bearing
12	119-B-12	2	Shim
13	119-B-13	2	Shim
14	119-B-14	2	Shim
15	119-B-15	2	Shim
16	119-B-16	2	Washer
17	119-B-17	2	Circlip
18	119-B-18	2	Seal Ring
19	119-B-19	1	Roller Bearing
20	119-B-20	1	Seal Ring
21	119-B-36	1	Round Shaft
22	119-B-22	1	Circlip
23	119-B-23	1	Washer
24	119-B-24	1	Bevel Gear
25	119-B-25	1	Spacer
26	119-B-26	2	Shim
27	119-B-27	2	Shim
28	119-B-28	2	Shim
29	119-B-29	2	Shim
30	119-B-30	1	Taper Bearing
31	119-B-31	2	Washer
32	119-B-32	2	Circlip
33	119-B-33	1	Circlip
34	119-B-34	1	Washer
35	119-B-35	1	Taper Roller Bearing

TRUCK MOUNT LOWER GEARBOX

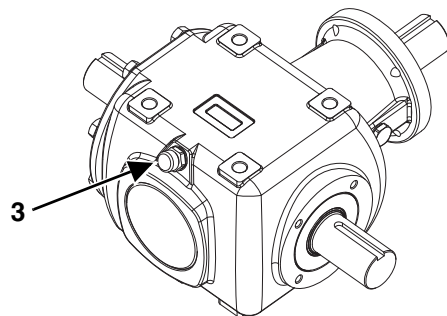
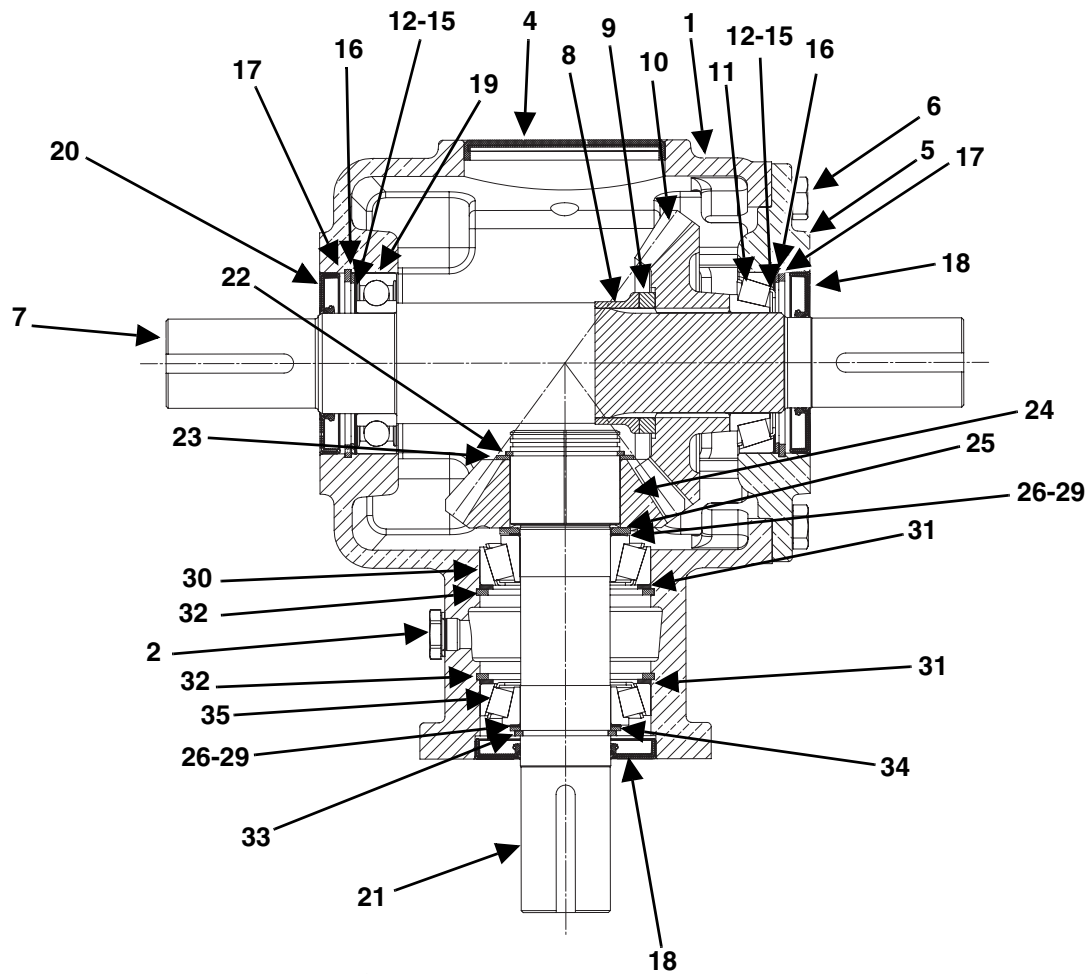

KEY	PART NUMBER	QTY	DESCRIPTION
0	119-R160-1.35-1	1	Gearbox
1	119-B-01	1	Casing
2	119-B-02	2	Oil Level / Drain Plug
3	119-B-03	1	Breather Plug
4	119-B-04	1	Cap
5	119-B-05	1	Top
6	119-B-06	8	M12-30 Bolt
7	119-B-07	1	Round Shaft
8	119-B-08	1	Spacer
9	119-B-09	1	Spacer
10	119-B-10	1	Bevel Gear
11	119-B-11	1	Taper Bearing
12	119-B-12	2	Shim
13	119-B-13	2	Shim
14	119-B-14	2	Shim
15	119-B-15	2	Shim
16	119-B-16	2	Washer
17	119-B-17	2	Circlip
18	119-B-18	2	Seal Ring
19	119-B-19	1	Roller Bearing
20	119-B-20	1	Seal Ring
21	119-B-21	1	Round Shaft
22	119-B-22	1	Circlip
23	119-B-23	1	Washer
24	119-B-24	1	Bevel Gear
25	119-B-25	1	Spacer
26	119-B-26	2	Shim
27	119-B-27	2	Shim
28	119-B-28	2	Shim
29	119-B-29	2	Shim
30	119-B-30	1	Taper Bearing
31	119-B-31	2	Washer
32	119-B-32	2	Circlip
33	119-B-33	1	Circlip
34	119-B-34	1	Washer
35	119-B-35	1	Taper Roller Bearing

TRUCK MOUNT CUT-OUT CLUTCH

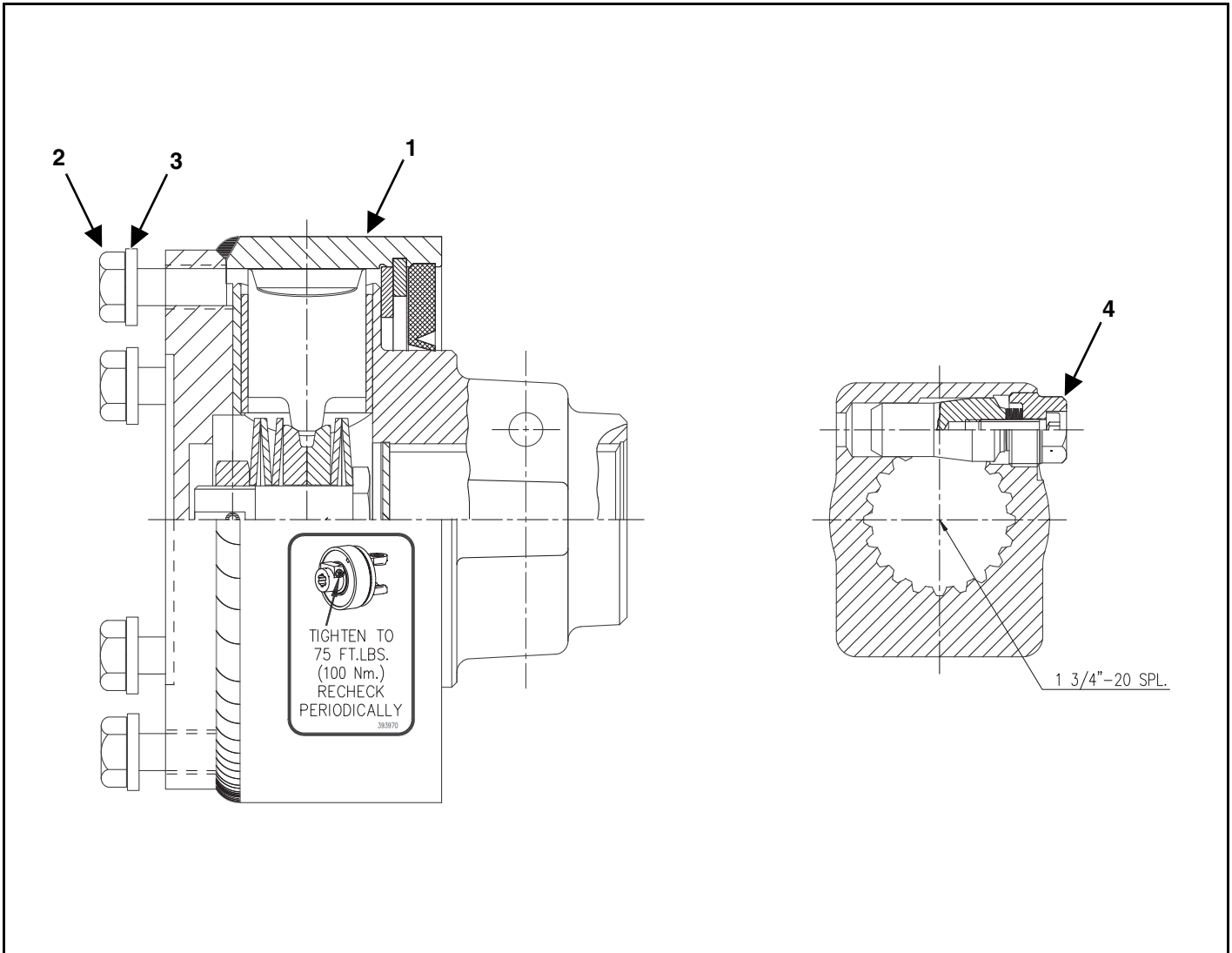

KEY	PART NUMBER	QTY	DESCRIPTION
1	918-0223-1-1	1	Cut-Out Clutch
2	918-0220-3	6	Bolt, Hex, M12 x 30mm
3	918-0220-4	6	Lock Washer
4	918-0410-2-1-1	1	Clamp Cone Bolt

10.0 OPTIONAL EQUIPMENT

KEY	DESCRIPTION	PAGE #
1	WEIGH BAR WIRING DIAGRAM (720 ONLY)	106
2	HYDRAULIC DRIVEN AUGER DRIVE COMPONENTS	108
3	HYDRAULIC DRIVEN AUGER BODY & SHIELDS	110
4	HYDRAULIC DRIVEN AUGER HYDRAULIC SCHEMATIC	112
5	HYDRAULIC DRIVEN AUGER FRONT HOSES	113
6	720 BRAKE COMPONENTS	114
7	720 FOOT CONTROL BRAKE SCHEMATIC	116
8	865 FOOT CONTROL BRAKE SCHEMATIC	118
9	865 HAND LEVER CONTROL BRAKE SCHEMATIC	120

WEIGH BAR WIRING DIAGRAM (720 ONLY)

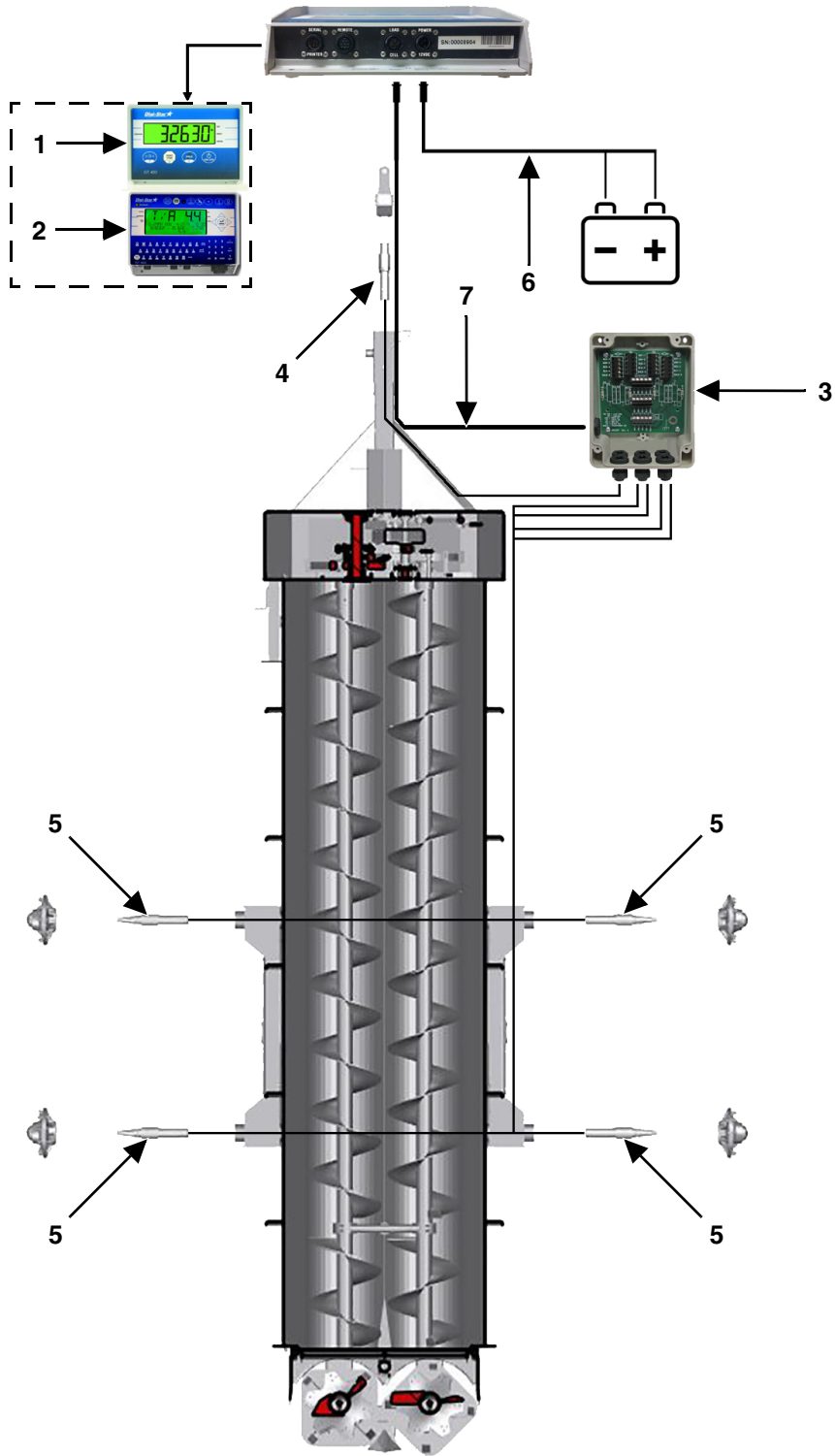

SXI-P-009

KEY	PART NUMBER	QTY	DESCRIPTION
1	58-0022	1	GT 400 Monitor
2	58-0016-SP	1	NT 460 Monitor
3	58-0020	1	6 Point J-Box
	58-0008	1	6 Point J-Box With Monitor Cable
4	58-0024	1	Front Hitch Weigh Bar, 2.875
5	58-0026	4	Spindle Load Cell, 2.875 (720)
	58-0027	4	Spindle Load Cell, 3.75 (865)
6	56-0236	1	Monitor To Auxiliary Power Cord Assembly
	56-0204	1	12V Male Plug Auxiliary Power Cord Assembly
	56-0136	1	3-Pin Auxiliary Power Cord Assembly
7	58-0029	1	Junction Box To Monitor Cable 30'
NS	25-0302	1	Scale Monitor Mount Bracket Assembly
NS	25-0303	1	Scale Monitor Mount Angle Welded Assembly

HYDRAULIC DRIVEN AUGER DRIVE COMPONENTS

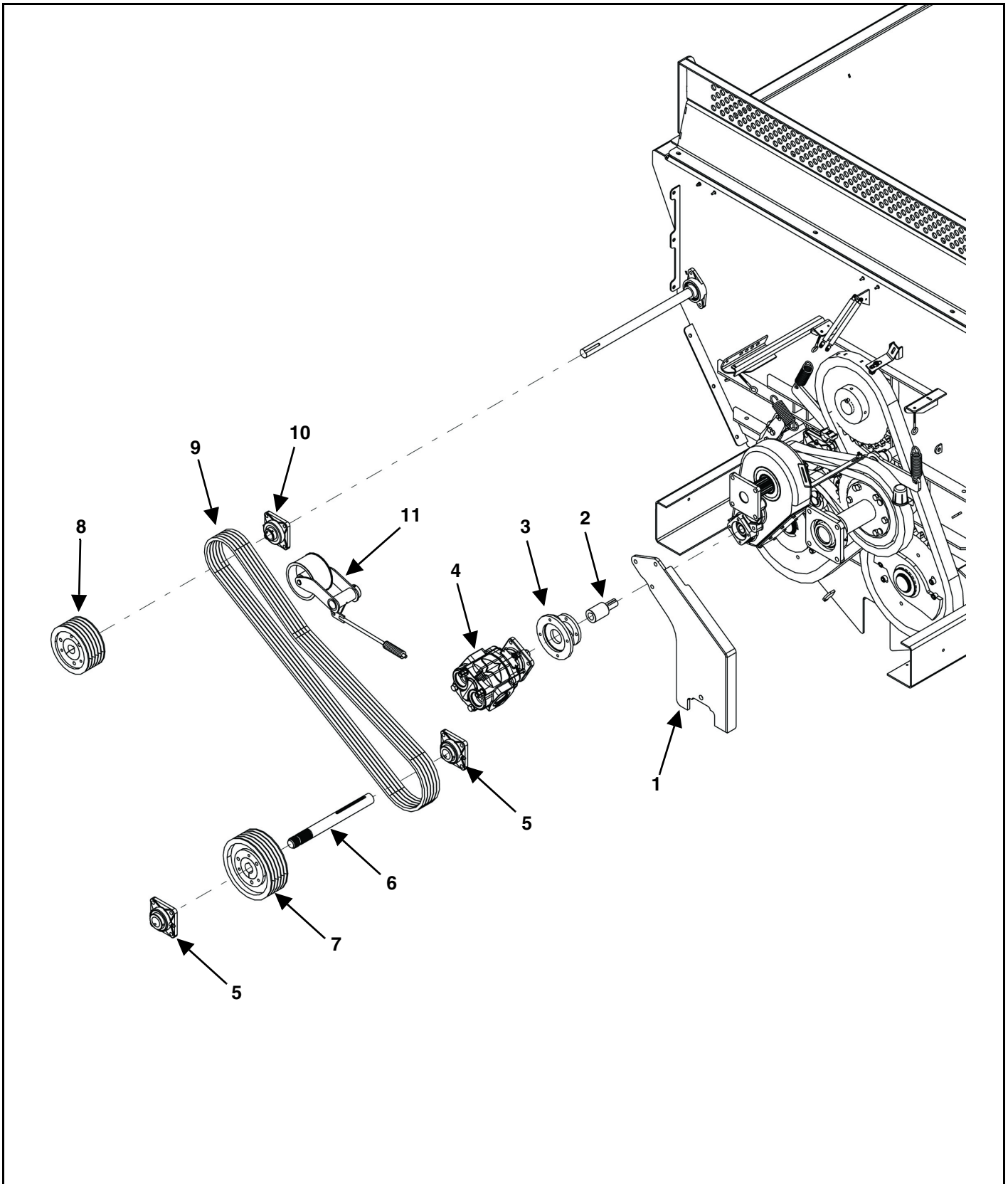

KEY	PART NUMBER	QTY	DESCRIPTION
1	925-0586	1	Torque Arm Weldment
2	923-0511	1	Adapter Shaft
3	901-0665	1	Motor To Gearbox Mount
4	See Page 112	1	Muncie Optimum Y62 Series Gear Pump
5	914-3819	2	1-3/4" 4-Bolt Flange Bearing
6	923-0521	1	Input Shaft
7	See Page 54	1	First Reduction And Spinner Drive
8	See Page 54	1	First Reduction And Spinner Drive
9	See Page 54	5	V-Belt
10	914-3602	1	1-1/2" 4-Bolt Flange Bearing
11	See Page 54	1	First Reduction And Spinner Drive

HYDRAULIC DRIVEN AUGER BODY & SHIELDS

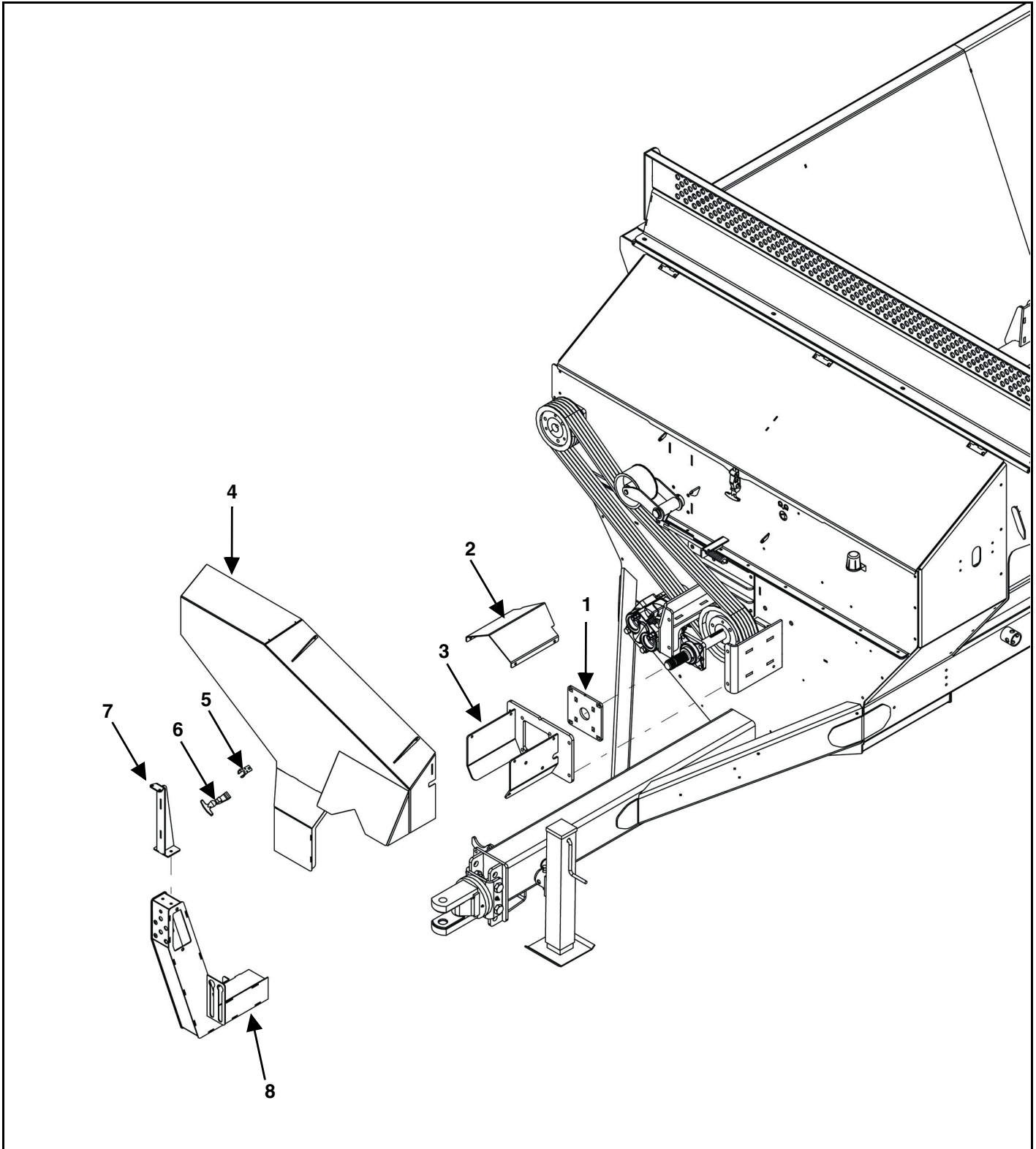

KEY	PART NUMBER	QTY	DESCRIPTION
1	901-0702-9	1	Bearing Mount Plate
2	924-0579	1	Input Shaft Cover
3	901-0663-10	1	Input Plate Weldment
4	924-0601-1	1	Belt Drive Shield Weldment
5	32-0032-3A	1	Lower Catch Keeper
6	32-0032-2	1	Rubber T-Latch With End Piece
7	901-0768	1	Hydraulic Hose Mount Weldment
8	901-0728	1	Bulkhead Weldment

HYDRAULIC DRIVEN AUGER HYDRAULIC SCHEMATIC

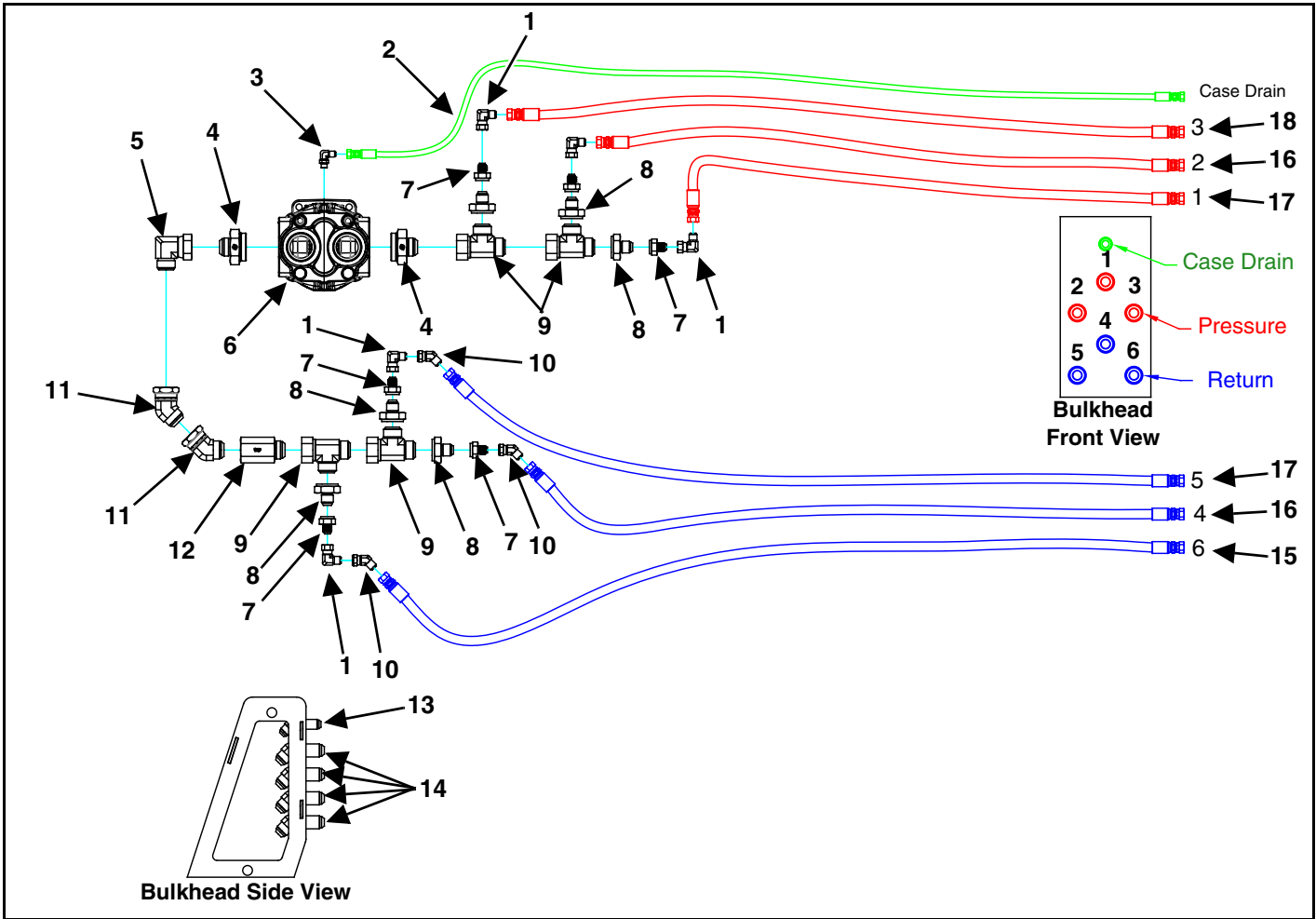

KEY	PART NUMBER	QTY	DESCRIPTION
1	155-6500-08-08	5	90 Degree Fitting
2	155-04R17-61-1	1	1/4" x 61" Hose
3	155-6801-06-06	1	90 Degree Fitting
4	155-6400-20-32	2	Straight Adapter
5	155-6500-20-20	1	90 Degree Fitting
6	155-Y62-14.39-1	1	Muncie Optimum Y62 Series Gear Pump
	155-Y62-14.39-1-1	1	Shaft Seal
7	155-2406-12-08	6	Straight Adapter
8	155-2406-20-12	6	Straight Adapter
9	155-6602-20	4	Tee Fitting
10	155-6502-08-08	3	45 Degree Fitting
11	155-6502-20-20	2	45 Degree Fitting
12	155-CV-1920FF	1	Check Valve
13	155-2702-LN-06-06	1	45 Degree Bulkhead With Lock Nut
14	155-2702-LN-08-08	6	45 Degree Bulkhead With Lock Nut
15	155-08R17-56-1	1	1/2" x 56" Hose
16	155-08R17-50-1	2	1/2" x 50" Hose
17	155-08R17-47-2	2	1/2" x 47" Hose
18	155-08R17-53-2	1	1/2" x 53" Hose

HYDRAULIC DRIVEN AUGER FRONT HOSES

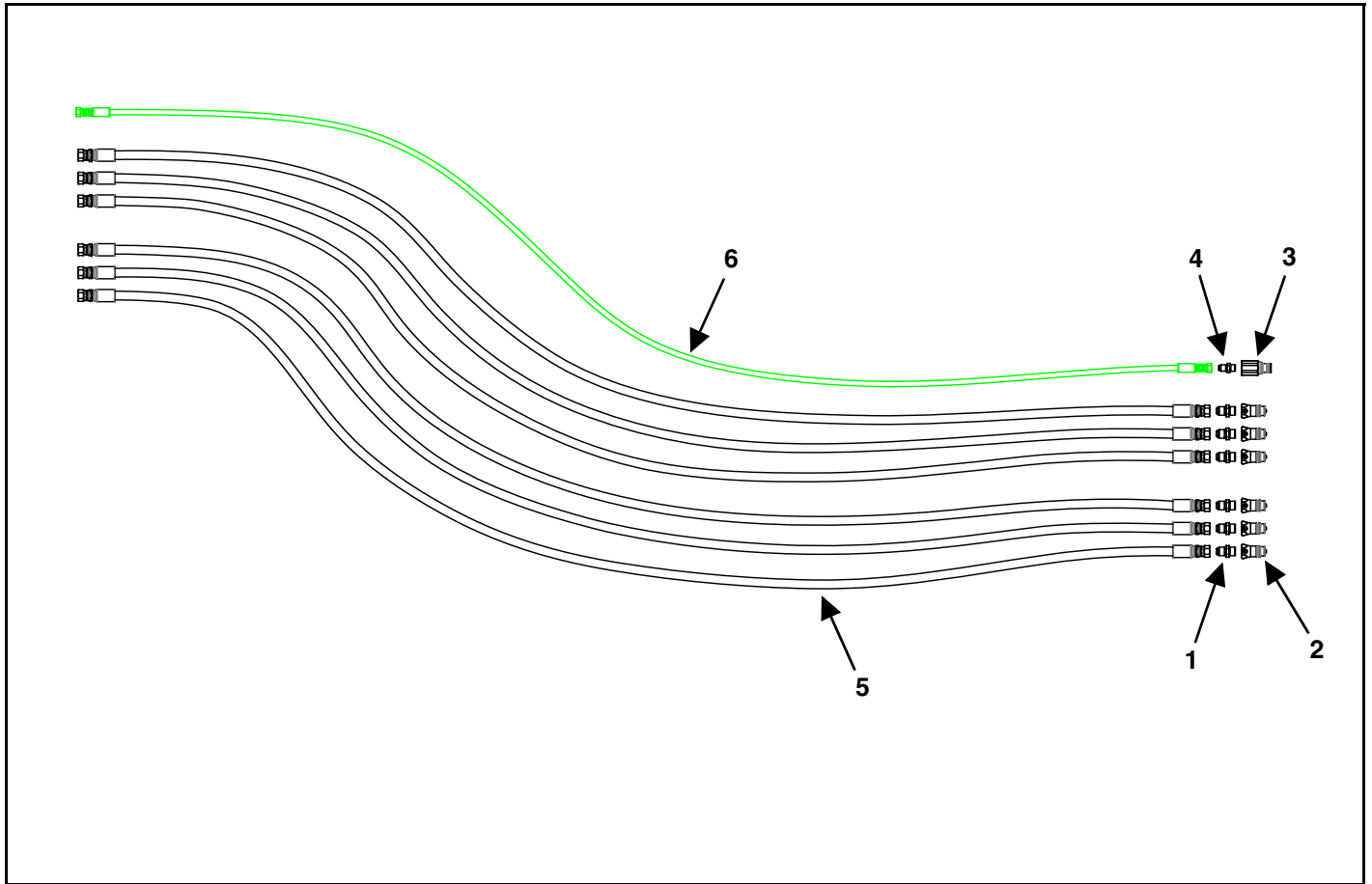

KEY	PART NUMBER	QTY	DESCRIPTION
1	155-6400-8-8	6	Straight Adapter
2	155-8010-15	6	Male Tip 1/2" Body Size
3	55-0346	1	3/8" Male Flat Face Quick Coupler
4	155-6400-06-06	1	Straight Adapter
5	155-08R17-81-1	6	1/2" x 81" Hose
6	155-04R17-82-1	1	1/4" x 82" Hose

720 BRAKE COMPONENTS

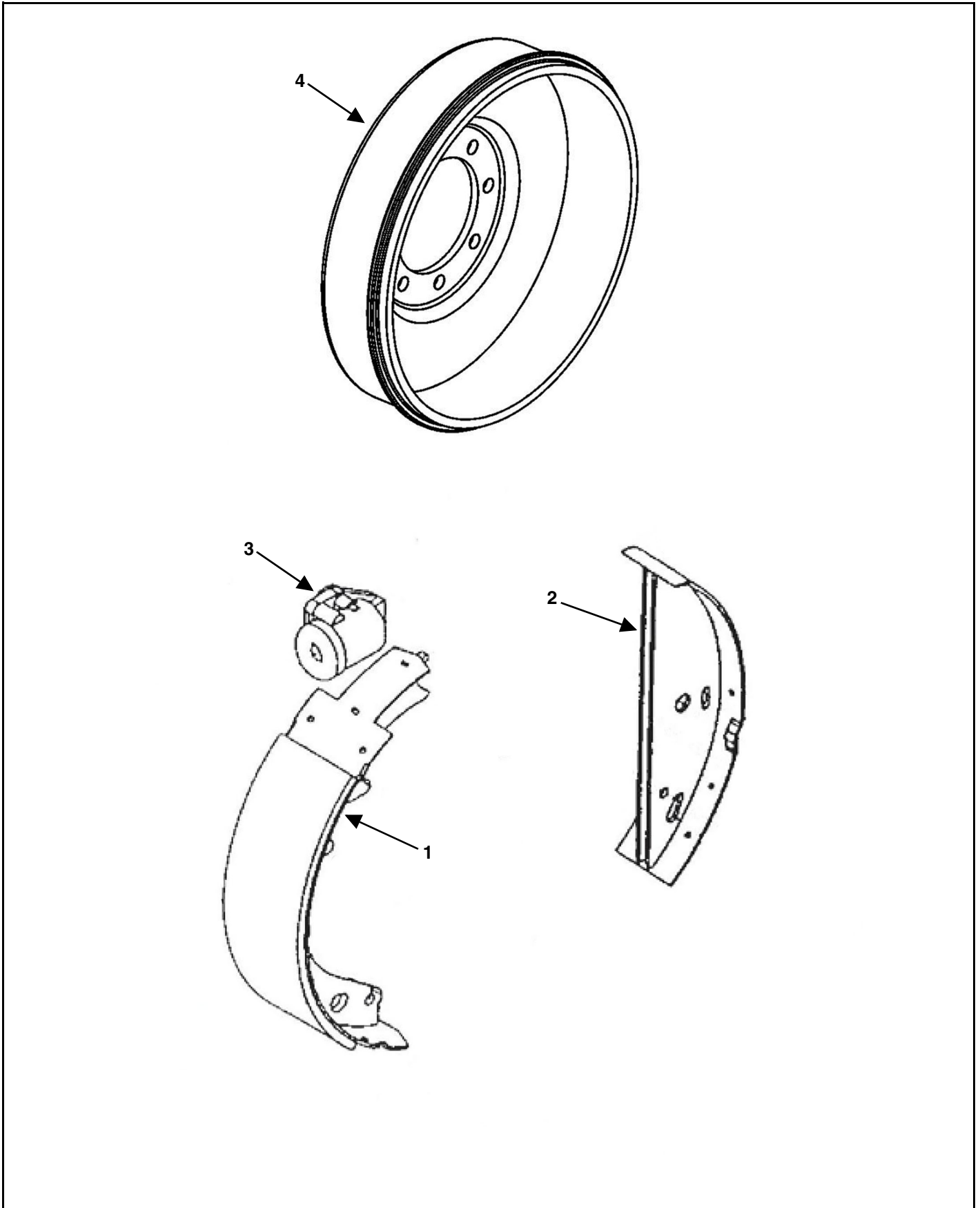

KEY	PART NUMBER	QTY	DESCRIPTION
0	57-0002	1	13" R.H. Free Backing Brake Assembly Without Drum
	57-0003	1	13" L.H. Free Backing Brake Assembly Without Drum
1	57-0002-5	1	Shoe Assembly
2	57-0002-3	1	Brake Shoe Assembly
3	57-0003-1	1	Wheel Cylinder Assembly Left
	57-0002-1	1	Wheel Cylinder Assembly Right (Not Shown)
4	57-0004	1	13" Brake Drum

720 FOOT CONTROL BRAKE SCHEMATIC

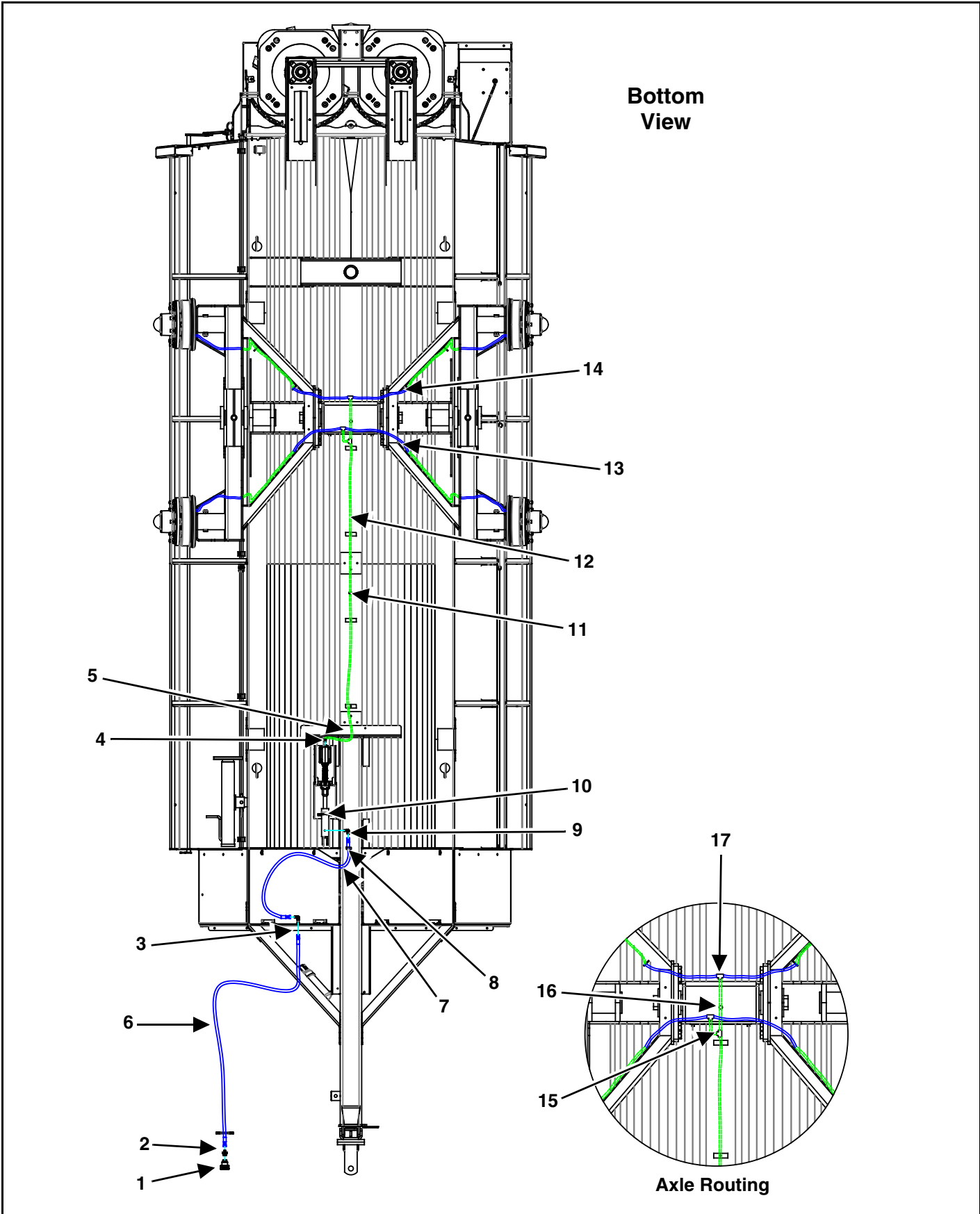

KEY	PART NUMBER	QTY	DESCRIPTION
1	55-0212	1	Female Flat Face Coupler
2	155-9002-6-8	1	Straight Adapter With O-Ring
3	155-2701-LN-06-06	1	90 Degree Bulkhead With Lock Nut
4	57-0029-17	1	Inverted Flare Full Flow Orifice
5	57-0015	1	30" Brake Line Assembly
	57-0021	1	41" Brake Line Assembly (SN SXI19720236 Only)
6	155-04R17-113-1	1	113" Hose
7	155-04R17-102-1	1	102" Hose
8	33-1016	1	Grommet
9	155-2501-06-04	1	90 Degree Fitting
10	75-2230	1	Brake Actuator Assembly
11	57-0014-2	1	Brake Line Union
12	57-0020	1	90" Brake Line Assembly
13	57-0054	8	16" Brake Hose
	57-0012	8	Hose Bracket Cup
14	57-0069	4	37" Brake Line Assembly
15	57-0053	1	6" Brake Line Assembly
16	57-0071	1	12" Brake Line Assembly
17	57-0013	3	Frame Tee With Cup

865 FOOT CONTROL BRAKE SCHEMATIC

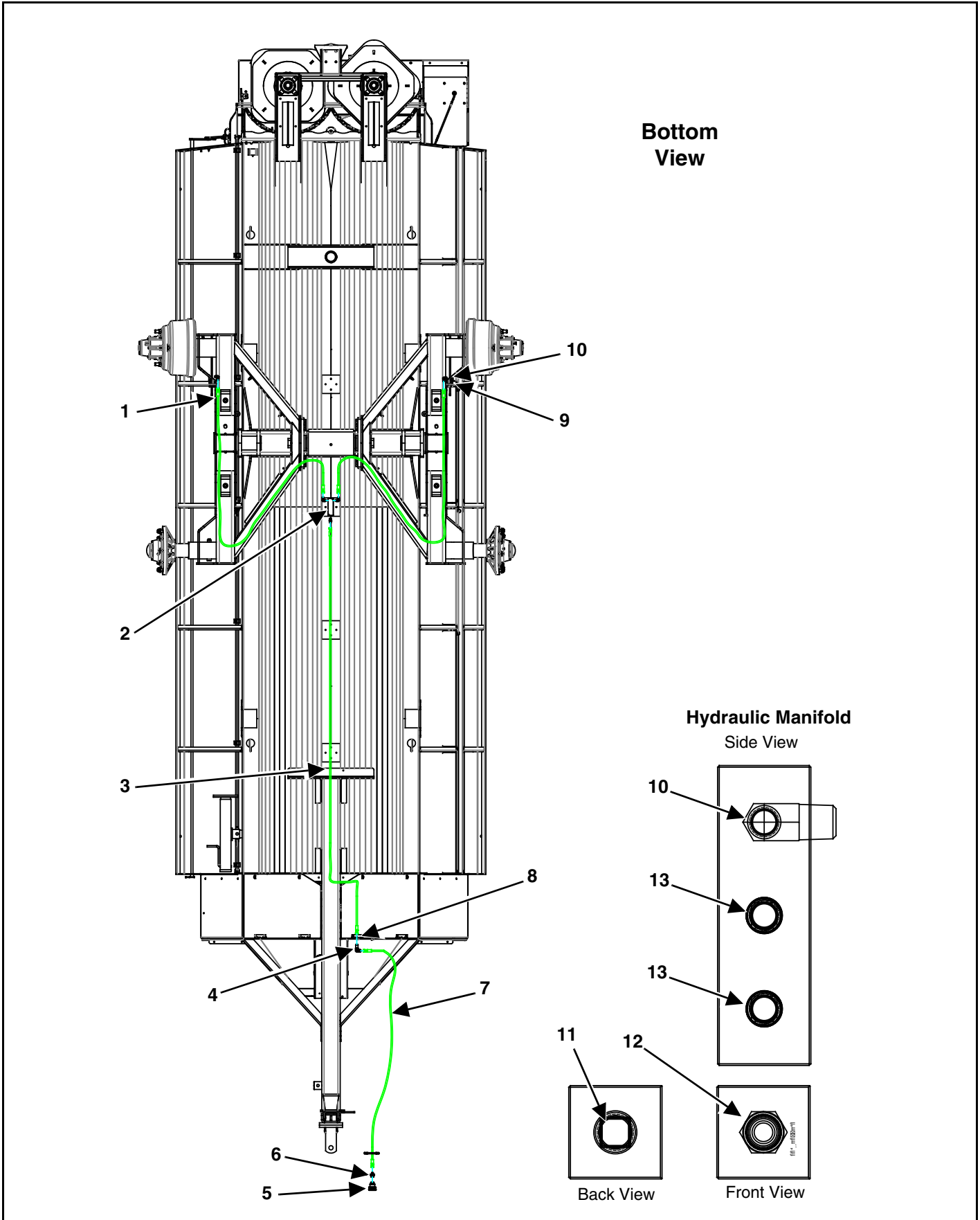

KEY	PART NUMBER	QTY	DESCRIPTION
1	155-04R17-110-1	2	110" Hose
2	57-0050	1	Aluminum Header Manifold Block
3	155-04R17-208-1	1	208" Hose
4	155-2701-LN-06-06	1	90 Degree Bulkhead With Lock Nut
5	55-0212	1	Female Flat Face Coupler
6	155-9002-6-8	1	Straight Adapter With O-Ring
7	155-04R17-113-1	1	113" Hose
8	33-1016	1	Grommet
9	955-3772-SPO	2	Hydraulic Brake Cylinder
10	155-2501-06-04	4	90 Degree Fitting
11	955-3809	1	3/8" Square Head Plug
12	155-2404-06-06	1	Straight Coupler
13	55-0167	4	1/4" Square Head Plug

865 HAND LEVER CONTROL BRAKE SCHEMATIC

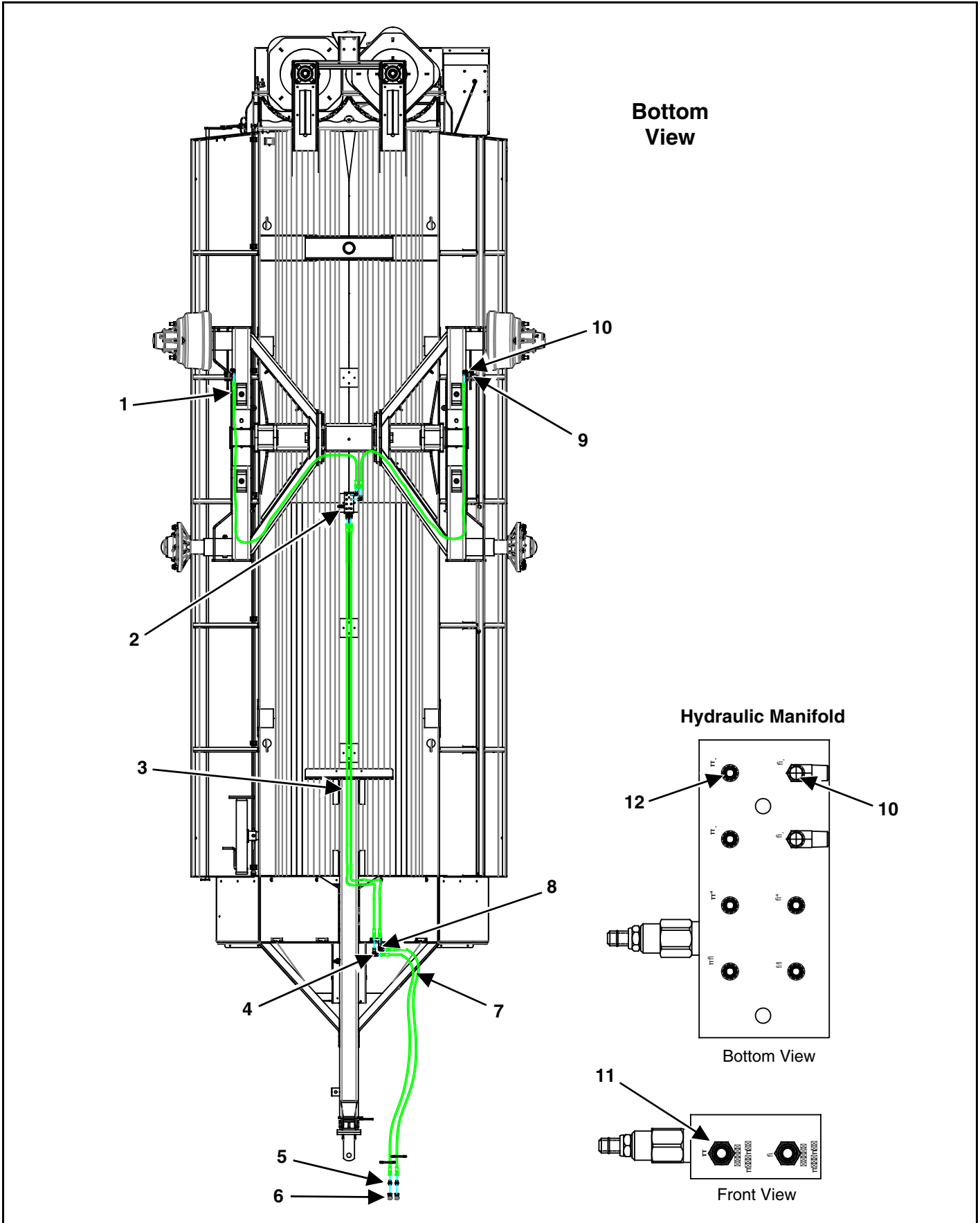

KEY	PART NUMBER	QTY	DESCRIPTION
1	155-04R17-110-2	2	110" Hose
2	57-0046	1	Relief Valve Manifold Block
3	155-04R17-208-1	2	208" Hose
4	155-2701-LN-06-06	2	90 Degree Bulkhead With Lock Nut
5	155-6400-6-8	2	Straight Coupler
6	155-8010-15	2	Male Tip 1/2"
7	155-04R17-113-1	2	113" Hose
8	33-1016	2	Grommet
9	955-3772-SPO	2	Hydraulic Brake Cylinder
10	155-2501-06-04	4	90 Degree Fitting
11	155-2404-06-04	2	Straight Adapter
12	55-0167	6	1/4" Square Head Plug



11.0 SPECIFICATIONS

DIMENSIONS / SPECIFICATIONS				
	Industrial SXI720 Trailer Type W/550/ 45 x 22.5 Tires	Industrial SXI720 Truck Mount W/ Mount Brackets	Industrial SXI865 Trailer Type W/ 28LX26 Tires	Industrial SXI865 Truck Mount W/ Mount Brackets
CAPACITY Bushels Heaped Gallons/Cu.ft. (struck) Cu. yards. (struck)	720 3500/468 17.33 cu. yards	720 3500/468 17.33 cu. yards	865 4200/562 20.8 cu. yards	865 4200/562 20.8 cu. yards
DIMENSIONS				
Overall Length	26' 6"	20' 10" w/ Hyd Motor	29' 10"	24' 2" w/Hyd Motor
Inside Tank Length	16' 8"	16' 8"	20'	20'
Loading Height	87" w/550/45 - 425/ 65 - 21.5 89" w/600/50x22.5"	68" plus truck height	89" w/28L x 26	68" plus truck height
Overall Height - Top of splash shield / guard	104" w/550/45 - 425/ 65 - 21.5, 106" w/ 600/50x22.5	85" plus truck height	105" w/28L x 26	85" plus truck height
Overall Width (std. axle) Outside Tires	119" w/550/45x22.5 126" w/600/50x22.5	101"	N/A	101"
Overall Width w/high flotation axle pkg.	142" w/28L x 26	NA	142" w/28L x 26	NA
Top Inside Tank Width	101"	101"	101"	101"
SPECIFICATIONS				
Total Weight	14,680# w/425/65	10,360# est w/PTO drive	17,820#	10,500# est w/PTO drive
Maximum Load Net (Lbs.)	35,200#	35,200#	38,000#	38,000#
Lower Auger Diameter	23"	23"	23"	23"
Lower Auger Flighting Thickness	3/8" sectional	3/8" sectional	3/8" sectional	3/8" sectional
Independent Lower Auger Shear Hub Sprockets	Standard	Standard	Standard	Standard
3rd Auger (solid material)	Standard - 16"	Standard - 16"	Standard - 16"	Standard - 16"
Drive - PTO-RPM	1000 RPM Constant Velocity 1 3/8-21 spline	PTO - Direct Std. Hydraulic - Optional	1000 RPM Constant Velocity 1 3/4-20 spline	PTO - Direct Std. Hydraulic - Optional
Drive Line Protection	Overrunning cut out clutch w/shear bolt augers	Cut out clutch w/ shear bolt augers (PTO version)	Overrunning cut out clutch w/shear bolt augers	Cut out clutch w/ shear bolt augers (PTO version)
Roller Chain Drive - Auger	RT Geardrive / #120- 140	RT Geardrive / #120- 140	RT Geardrive / #120- 140	RT Geardrive / #120- 140
Belt Drive - Expeller	V-Belt	V-Belt	V-Belt	V-Belt
Roller Chain Auto Oiler	Standard	Standard	Standard	Standard
Expeller Speed (RPM)	718 RPM	718 RPM	718 RPM	718 RPM
Expeller Diameter	30"	30"	30"	30"

DIMENSIONS / SPECIFICATIONS

	Industrial SXI720 Trailer Type W/550/ 45 x 22.5 Tires	Industrial SXI720 Truck Mount W/ Mount Brackets	Industrial SXI865 Trailer Type W/ 28LX26 Tires	Industrial SXI865 Truck Mount W/ Mount Brackets
TANK CONSTRUCTION				
Material	Copper bearing steel	Copper bearing steel	Copper bearing steel	Copper bearing steel
Thickness - Auger Troughs	1/4"	1/4"	1/4"	1/4"
Thickness - Tank Sides	3/16"	3/16"	3/16"	3/16"
Frame Construction	HD Formed Channel	HD Formed Channel	HD Formed Channel	HD Formed Channel
Door Opening	32" x 53"	32" x 53"	32" x 53"	32" x 53"
Standard Axle Spindle Diameter	Standard Tandem 3 1/2" sleeved	NA	N/A	NA
High Flotation Axle Spindle Diameter	Optional Tandem 4 1/2" sleeved	NA	Standard Tandem 4 1/2" sleeved	NA
Standard Axle Hub Size	10 bolt-15,000#	NA	N/A	NA
High Flotation Axle Hub Size	10 bolt-20,000# (opt.)	NA	10 bolt-20,000# (std.)	NA
Splash Shields-Standard	Angled style front / rear	Angled style front / rear	Angled style front / rear	Angled style front / rear
LED transport lights w/ag plug	Standard	Standard	Standard	Standard
Tractor Requirement PTO HP (Min.)	140 HP Tractor	NA	170 HP Tractor	NA
OPTIONS				
1000 RPM 1 3/4"-20 spline	Optional	NA	Standard	NA
Hydraulic Lid	Optional	Optional	Optional	Optional
Poultry Litter Package	Optional	Optional	Optional	Optional
High Flotation Axle Package	Optional	NA	Standard	NA
Hyd. Brakes-HF axle only	Optional (2 or 4 wheel)	NA	Optional (2 or 4 wheel)	NA
Safety Chain	Optional	NA	Optional	NA
Truck Mount Drive Options	NA	PTO - Direct Std. Hydraulic - Opt	NA	PTO - Direct Std. Hydraulic - Opt
Variable Speed Auger Drive	Call	Call	Call	Call



Meyer Manufacturing Corporation

674 W. Business Cty Rd A

Dorchester, WI 54425

Phone. 1-800-325-9103

Fax: 715-654-5513

Email: parts@meyermfg.com

Website: www.meyermfg.com