

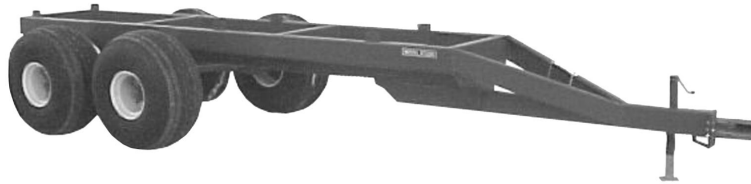

XT2200 SERIES



XT1600 SERIES

## XT TRAILER

XT1600 • XT1600L: 2014 Through 2020 Model Year  
XT/XTL/XTH22-216 • XT/XTL/XTH22-240 • XT/XTL/XTH22-264 •  
XT/XTL/XTH22-280: SN 1422XT309 Through 2020 Model Year

---

5 Point Scale Models: XT16-162-WS • XT16-202-WS • XT/XTL/XTH22-216-WS • XT/XTL/XTH22-240-WS •  
XT/XTL/XTH22-264-WS • XT/XTL/XTH22-280-WS: 2013 Through 2020 Model Year



# Owner / Operator's Manual & Parts Book



## 1.0 IMPORTANT INFORMATION

Prior to 2016 model year, the serial number is stamped on the front left hand frame tube.

For 2016 model year and later, the serial number plate is located on the front trailer plate behind the left hitch wing.

Please enter the model, serial number and additional information in the space provided for future reference.



Model No. \_\_\_\_\_  
Serial No. \_\_\_\_\_  
Date of Purchase \_\_\_\_\_  
Dealership \_\_\_\_\_  
Dealership Phone No. \_\_\_\_\_



**Always use your serial number when requesting information or when ordering parts.**

### HOW TO READ YOUR SERIAL NUMBER

EXAMPLE: 1422XT253

Model Year / Model / Sequence Of Build

↓            ↓            ↓  
**14      22XT      253**

---

Meyer Manufacturing Corporation

674 W. Business Cty Rd A

Dorchester, WI 54425

Phone: 1-800-325-9103

Fax: 715-654-5513

Email: [parts@meyermfg.com](mailto:parts@meyermfg.com)

Website: [www.meyermfg.com](http://www.meyermfg.com)



## 2.0 INTRODUCTION

*Congratulations on your purchase of a new Meyer farm equipment product. Undoubtedly you have given much consideration to your purchase and we're proud that you have selected Meyer. Pride in craftsmanship, engineering and customer service have made Meyer products the finest in the farm equipment industry today.*

*There is no substitute for quality. That is why thousands of people like you have purchased Meyer farm equipment. They felt it was the best equipment to serve their farming needs, now and in years to come. We ask that you follow our policy of "safety first", and we strongly suggest that you read through the Operator's & Parts manual before operating your Meyer farm equipment. Meyer Manufacturing Corporation wants to thank you for not compromising quality. We are determined to offer excellence in customer service as well as provide you with the very best value for your dollar.*

*Sincerely,*

*All Employees of*

*MEYER MANUFACTURING CORPORATION*

---

The Model Trailer may be referred to as equipment, machine, or trailer in this manual.

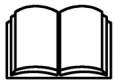

**IMPORTANT:** You are urged to study this manual and follow the instructions carefully. Your efforts will be repaid in better operation and service as well as a savings in time and repair expense. Failure to read this manual and understand the machine could lead to serious injury. If you do not understand instructions in this manual, contact either your dealer or Meyer Manufacturing Corp. at Dorchester, WI 54425.

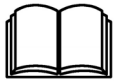

**WARRANTY:** Be sure your dealer has completed the "Owner's Registration Form" that is included with their invoice, and promptly forwarded a copy to Meyer Manufacturing to validate the manufacturer's warranty. The product model and serial number are recorded on this form and on the inside of the front cover for proper identification of your Meyer Trailer by your dealer and the manufacturer when ordering repair parts. The serial number is stamped on the front left hand frame tube.



**REPAIR PARTS:** At the back of this manual is the repair parts section. All replacement parts are to be obtained from or ordered through your Meyer dealership. When ordering repair parts, refer to the parts section and give complete information including quantity, correct part number, detailed description and even Model No. and Serial No. of the trailer which needs repair parts.

**Manufacturer's Statement:** Meyer Manufacturing Corporation reserves the right to make improvements in design, or changes in specifications at any time, without incurring any obligation to owners of units previously sold. This supersedes all previous published instructions.



FARM EQUIPMENT BUYERS TRUST THE NAME MEYER!

## TABLE OF CONTENTS

1.0	IMPORTANT INFORMATION	2
2.0	INTRODUCTION	3
3.0	MANUFACTURER'S WARRANTY	9
4.0	SAFETY	11
4.1	SAFETY PRECAUTIONS	12
4.1.1	Farm Implement Tires	13
4.2	SAFETY SIGNS	14
4.3	SHUTOFF & LOCKOUT POWER	15
4.3.1	Shutoff & Lockout Power Recommendations	15
5.0	PRE-OPERATION	17
5.1	PRODUCT INSPECTION	17
5.1.1	Before Operating The Trailer	17
5.1.2	General Inspection	18
5.2	HITCHING TO TRACTOR	18
5.3	OPERATIONAL CHECKS	18
5.4	TRANSPORTING	19
5.4.1	Safety Chain	20
5.4.2	Trailer Brake System (Optional)	21
5.4.3	Tractor Towing Size Requirements	21
6.0	OPERATION	23
6.1	UNHOOKING THE TRACTOR	23
7.0	MAINTENANCE	25
7.1	LUBRICATION	25
	Inspection	26
7.1.1	Pack Wheel Bearings	26
7.2	ADJUSTMENTS	26
7.2.1	Adjust Wheel Bearing Preload	26
7.2.2	Wheel Torque Requirements	26
7.2.3	Brakes (Optional)	27
7.2.3.1	Brake Adjustment	27
7.2.3.2	Brake Bleeding	27
7.3	FARM IMPLEMENT TIRES	28
7.3.1	Service And Maintenance Tips	28

7.3.2	Tire Inflation .....	29
7.4	STORING THE TRAILER .....	30
7.5	RETURNING THE TRAILER TO SERVICE .....	30
8.0	PARTS REPAIR AND REPLACEMENT .....	31
8.1	REPLACEMENT PARTS .....	31
8.1.1	Shutoff & Lockout Power Recommendations .....	31
	XT1600 SERIES FRAME AND O-BEAM (WITHOUT 5-POINT SCALE) .....	34
	XT1600 SERIES FRAME AND O-BEAM (WITH 5-POINT SCALE) .....	36
	XT2200 O-BEAM SERIAL NUMBER DIRECTORY .....	38
	XT2200 & XT2200+ SERIES FRAME (WITHOUT 5-POINT SCALE) .....	39
	OLD STYLE O-BEAM (WITHOUT 5-POINT SCALE) .....	40
	NEW STYLE O-BEAM (WITHOUT 5-POINT SCALE) .....	42
	XT2200 & XT/XTL/XTH2200+ SERIES FRAME (WITH 5-POINT SCALE) .....	44
	OLD STYLE O-BEAM (WITH 5-POINT SCALE) .....	46
	NEW STYLE O-BEAM (WITH 5-POINT SCALE) .....	48
	HUB FOR XT1600 SERIES .....	50
	HUB FOR XT2200 & XT/XTH/XTL2200+ SERIES .....	51
	XT SERIES OPTIONAL SURGE BRAKE ACTUATOR ASSEMBLY .....	52
	XTL2200+ AND XTH2200+ SERIES OPTIONAL SURGE BRAKE ACTUATOR ASSEMBLY .....	56
	XT/XTL/XTH SERIES OPTIONAL HAND/FOOT BRAKE CONTROL ACTUATOR ASSEMBLY .....	58
	XT SERIES OPTIONAL DRUM BRAKE ASSEMBLY .....	60
	SURGE BRAKE PLUMBING .....	61
	HAND LEVER CONTROL BRAKE PLUMBING .....	62
	FOOT PEDAL CONTROL BRAKE PLUMBING .....	63
9.0	SPECIFICATIONS .....	65
	SUSPENSION TRAILER SPECIFICATIONS .....	65

OPTIONS .....65  
TRAILER AND BOX MOUNTING SPECIFICATION SHEET .....66  
MAINTENANCE RECORD .....67





### 3.0 MANUFACTURER'S WARRANTY

3/2015

#### MEYER XT TRAILER

- I. The "Owner's Registration Form" must be completed in full and promptly returned to Meyer Mfg. Corp. for this warranty to become both valid and effective. All warranties on new Meyer XT Trailers shall apply only to the original retail customer from an authorized Meyer Mfg. Corp. dealership.
- II. This warranty shall not apply to any Meyer XT Trailer which has been subjected to misuse, negligence, alteration, accident, incorrect operating procedures, has been used for an application not designed for or pre-authorized by Meyer in writing, has had the serial numbers altered, or which shall have been repaired with parts other than those obtained through Meyer Mfg. Corp. Meyer is not responsible for the following: Depreciation or damage caused by normal wear, lack of reasonable and proper maintenance, failure to follow the operator's manual recommendations or normal maintenance parts and service. Meyer is not responsible for rental of replacement equipment during warranty repairs, damage to a power unit (including but not limited to a truck or tractor), loss of earnings due to equipment down time, or damage to equipment while in transit to or from the factory or dealer.
- III. Meyer Mfg. Corp. warrants new Meyer XT Trailer to be free from defects in material and workmanship under recommended use and maintenance service, as stated in the "Owner / Operator's Manual & Parts Book", as follows:
  - A. Meyer Mfg. Corp. will repair or replace F.O.B. Dorchester, WI, as Meyer Mfg. Corp. elects, any part of a new Meyer XT Trailer which is defective in material or workmanship:
    - i. Without charge for either parts or labor during the first (1) year from purchase date to the original retail customer.
    - ii. Without charge for parts only during the second (2) year from purchase date to the original retail customer.
- IV. COMMERCIAL USE: Coverage as in paragraph III.A. only, except warranty coverage is for (90) days for parts and labor to the original commercial retail customer.
- V. Repairs eligible for labor warranty must be made by Meyer Mfg. Corp. or an authorized Meyer dealership. The original retail customer is responsible for any service call and/or transportation of the XT Trailer to the dealership or the factory for warranty service.
- VI. Except as stated above, Meyer Mfg. Corp. shall not be liable for injuries or damages of any kind or nature, direct, consequential, or contingent, to persons or property. This warranty does not extend to loss of crop or for any other reasons.
- VII. No person is authorized to give any other warranties or to assume any other obligation on Meyer Mfg. Corp.'s behalf unless made or assumed in writing by Meyer Mfg. Corp. This warranty is the sole and exclusive warranty which is applicable in connection with the manufacture and sale of this product and Meyer Mfg. Corp.'s responsibility is limited accordingly.

#### Purchased Product Warranty:

This warranty does not apply to component parts not manufactured by Meyer such as but not limited to wheels, tires, tubes, scales, etc.



## 4.0 SAFETY

The Meyer XT Trailer is manufactured with operator safety in mind. Located on the trailer are various safety signs to aid in operation and warn of hazardous areas. Pay close attention to all safety signs on the trailer.

Carefully follow the operating and maintenance instructions in this manual and all applicable safety laws. Failure to follow all safety procedures may result in serious injury or death.

**Before attempting to operate the trailer, read and study the following safety information. In addition, make sure that every individual who operates or works with the trailer, whether family member or employee, is familiar with these safety precautions.**

Meyer Mfg. Corp. provides guards for exposed moving parts for the operator's protection; however, some areas cannot be guarded or shielded in order to assure proper operation. The operator's manual and safety signs on the trailer itself warn you of hazards and must be read and observed closely!



### Safety Alert Symbol

This symbol is used to call attention to instructions concerning personal safety. Be sure to observe and follow these instructions. Take time to be careful!

---



**DANGER**

The signal word **DANGER** on the machine and in the manual identifies a hazardous situation which, if not avoided, WILL result in death or serious injury.



**WARNING**

The signal word **WARNING** on the machine and in the manual indicates a potentially hazardous situation which, if not avoided, COULD result in death or serious injury.



**CAUTION**

The signal word **CAUTION** on the machine and in the manual indicates a potentially hazardous situation which, if not avoided, MAY result in minor or moderate injury. It may also be used to alert against unsafe practices.

**IMPORTANT**

This notice identifies procedures which must be followed to avoid damage to the machine.

Danger, Warning, Caution, and instructional decals and plates are placed on the equipment to protect anyone working on or around this machine, as well as the components of the machine. All personnel operating or maintaining this equipment must familiarize themselves with all Danger, Warning, Caution, and instructional decals and plates.

## 4.1 SAFETY PRECAUTIONS



**All individuals who will operate this trailer must read and completely understand this Operator's And Parts Manual. Operator must have instructions before operating the machine. Untrained operators can cause injury or death.**

- DO NOT allow anyone to operate, service, inspect or otherwise handle this equipment until all operators have read and understood all of the instructional materials in this Operator's And Parts Manual and have been properly trained in its intended usage.
- For an operator to be qualified, he or she must not use drugs or alcohol which impair alertness or coordination while working. An operator who is taking prescription drugs must get medical advice to determine if he or she can safely operate a machine and the equipment.
- Make sure all personnel can READ and UNDERSTAND all safety signs.
- DO NOT allow minors (children) or inexperienced persons to operate this trailer.
- DO NOT operate until all shields and guards are in place and securely fastened.
- DO NOT step up on any part of the trailer at any time.
- DO NOT adjust, clean or lubricate while the trailer is in motion.
- Inspect when first delivered and regularly thereafter; that all connections and bolts are tight and secure before operating.
- Make certain area is clear of people, tools, and other objects before moving the trailer.
- Keep hands, feet and clothing away from moving parts. Loose or floppy clothing should not be worn by the operator.
- Observe all applicable traffic laws when transporting on public roadways (where legal to do so). Check local laws for all highway lighting and marking requirements.
- Always enter curves or drive up or down hills at a low speed and at a gradual steering angle.
- Never allow riders on either tractor / truck or equipment.
- Keep tractor / truck in a lower gear at all times when traveling down steep grades.
- Maintain proper brake settings at all times (if equipped).
- Stay away from overhead power lines. Electrocutation can occur without direct contact.
- Use only properly rated undercarriage and tires.
- Do not exceed 20 mph (32 kph). Reduce speed on rough roads and surfaces.
- Always install a SMV emblem on pull-type equipment when transporting on roadways and keep clean and bright.
- Always yield to oncoming traffic in all situations and move to the side of the road so any following traffic may pass.

#### 4.1.1 Farm Implement Tires

##### *Recommended Safety Precautions*

- Always remove the valve core and deflate the tire before any work is performed.
- Always use the proper and approved tools to demount and mount the tire.
- Always inspect all rim/wheel parts for wear, damage, cracks, rust or mismatched components.
- Always destroy damaged or unserviceable parts.
- Always inspect the tube and tire for cord or side damage, cuts or wear. Unrepairable damaged items must be discarded.
- Always check for mismatched components or tire and wheel sizes.
- Always lubricate tire with a non-flammable tire lubricant approved for that purpose.
- Always place tire and wheel in inflation cage or restraining device before inflating beyond 5 PSI.
- Always use an extension hose with a PSI gauge and clip on chuck when inflating the tire so you can stand to one side.

##### *Non - Recommended Safety Precautions*

- Never work on a tire / wheel assembly before removing the valve core and completely deflating.
- Never re-inflate a tire that has been run flat or in an under inflated condition before removing and inspection.
- Never reuse damaged, defective, worn or mismatched parts.
- Never rework, weld, heat or braze any rim / wheel parts for any reason.
- Never inflate any tire beyond 40 PSI to seat the beads. If beads are not seated at 40 PSI. STOP! Deflate and determine problem.
- Never hammer, strike or pry on a rim / wheel assembly that contains any inflation pressure.
- Never inflate a tire without using an inflation cage or restraining device.
- Never inflate beyond the maximum PSI specified for the tire or rim.

## 4.2 SAFETY SIGNS

# CAUTION

Read all safety signs on the trailer and in this manual. Keep all safety signs clean and replace any damaged or missing safety signs before operating the equipment. Do Not remove any safety signs. Safety signs are for operator protection and information.

## WARNING



### CRUSHING HAZARD

To prevent serious injury or death:

- Keep hands and body out of hitch area when attaching towing vehicle.
- Keep body clear of crush point between towing vehicle and load.

46-0800-6

## WARNING



### RUN-AWAY HAZARD

To prevent serious injury or death:

- Shift to lower gear before going down steep grades.
- Keep towing vehicle in gear at all times.
- Never exceed a safe travel speed.

46-0800-7 1

## WARNING

To prevent serious injury or death:

- Read and understand owner's manual before using. Review safety precautions annually.
- No riders allowed when transporting.
- Securely attach to towing unit. Use a high strength appropriately sized hitch pin with a mechanical retainer and attach safety chain.
- Do not exceed 20 mph (33 kph). Slow down for corners and rough terrain.
- Do not drink and drive.
- Before moving running gear, be sure required lights and reflectors are installed and working.
- Before maintenance or repair, stop vehicle, set parking brake, and remove ignition key.
- Place safety stands under frame and chock wheels before working on tires or running gear.
- Maintain wheel bolts at torque as recommended in the manual.
- If equipped with brakes, maintain proper adjustment.

46-0800-8

## 4.3 SHUTOFF & LOCKOUT POWER

Any individual that will be adjusting, servicing, maintaining, or clearing an obstruction from this machine needs to ensure that this machine stays safely “OFF” until the adjustment, service, or maintenance has been completed, or when the obstruction has been cleared, and that all guards, shields, and covers have been restored to their original position. The safety of all individuals working on or around this machine, including family members, are affected. The following procedure will be referred to throughout this manual, so be familiar with the following steps.

### 4.3.1 Shutoff & Lockout Power Recommendations

#### 1. Think, Plan and Check

- a. **Think** through the entire procedure and identify all the steps that are required.
- b. **Plan** what personnel will be involved, what needs to be shut down, what guards / shields need to be removed, and how the equipment will be restarted.
- c. **Check** the machine over to verify all power sources and stored energy have been identified including engines, hydraulic and pneumatic systems, springs and accumulators, and suspended loads.

#### 2. Communicate - Inform everyone involved, including those working on or around this machine, that work is being done which involves keeping this machine safely “OFF”.

#### 3. Power Sources

- a. **LOCKOUT** - Shut off engines and take the key, or physically lock the start/on switch or control. Disconnect any power sources which are meant to be disconnected (i.e. electrical, hydraulic, and PTO of pull-type units).
- b. **TAGOUT** - Place a tag on the machine noting the reason for the power source being tagged out and what work is being done. This is particularly important if the power source is not within your sight and/or will need to be isolated for a longer period of time.

#### 4. Stored Energy - Neutralize all stored energy from its power source. Ensure that this machine is level, set the parking brake, and chock the wheels. Disconnect electricity, block moveable parts, release or block spring energy, release pressure from hydraulic and pneumatic lines, and lower suspended parts to a resting position.

#### 5. Test - Do a complete test and personally double check all of the above steps to verify that all of the power sources are actually disconnected and locked out.

#### 6. Restore Power - When the work has been completed, follow the same basic procedures, ensuring that all individuals working on or around this machine are safely clear of the machine before locks and tags are removed and power is restored.

**IMPORTANT**

It is important that everyone who works on this equipment is properly trained to help ensure that they are familiar with this procedure and that they follow the steps outlined above. This manual will remind you when to Shutoff & Lockout Power.





## 5.0 PRE-OPERATION



### CAUTION

DO NOT allow anyone to operate, service, inspect or otherwise handle this trailer until all operators have read and understand all of the instructional materials in this Operator's And Parts Manual and have been properly trained in its intended usage.

Verify that the trailer is securely fastened to the tractor / truck.

Verify that all connections and bolts / hardware are tight and securely fastened before operating the trailer.

Always keep all shields and guards in place and securely fastened.

Keep hands, feet and clothing away.

Wear safety glasses to prevent eye injury when any of the following conditions exist:

- When fluids are under pressure.
- Flying debris or loose material is present.
- Tools are being used.

### 5.1 PRODUCT INSPECTION



### WARNING

Before using any equipment equipped with brakes the operation of the brakes should be checked. Failure to heed may result in serious personal injury or death.

#### 5.1.1 Before Operating The Trailer

Before operating the trailer for the first time and each time thereafter, check the following items:

1. Inspect the trailer to verify that all connections and bolts are tight and secure before operating.
2. Lubricate the equipment. (See Inspection on page 26.)
3. Make sure area is clear of people, tools, and other objects before moving trailer.
4. Check tires for proper inflation.
5. Use only properly rated running gear and tires.
6. Check that the brakes are clean and clean them if necessary.

### 5.1.2 General Inspection



Inspect the chassis' axles, o-beams, spindles, tires, hitches, safety shielding, safety signs and safety lighting regularly. These parts if not watched closely, could pose potential injury or death. If any part is found in need of repair, follow the SHUTOFF & LOCKOUT POWER recommendations and have qualified personnel repair immediately.

Check to see that no obstructions are present on the trailer prior to use. Be sure that there are not tools laying on the trailer.

**NOTE: The PTO horsepower requirements may not reflect adequate tractor size for towing the machine. Refer to tractor weight requirements for these recommendations and safety section for additional tractor and towing requirements.**

### 5.2 HITCHING TO TRACTOR

Move to the operator's position, start the engine and release the parking brake.



**Do not allow anyone to stand between the tongue or hitch and the tractor when backing up to the Trailer.**

Move the tractor in front of the trailer. Slowly move the tractor backwards towards the trailer and align the drawbar with the implement's hitch.

**NOTE: Lower or raise the trailer jack to properly align the drawbar and hitch.**

Fasten the trailer hitch to the tractor drawbar with a properly sized hitch pin with safety retainer. (Reference ANSI/ASABE AD6489-3 Agricultural vehicles - Mechanical connections between towed and towing vehicles - Part 3: Tractor drawbar.)

Before operation and after hitching the tractor to the implement, connect the light cords or any optional equipment connections to the tractor.

### 5.3 OPERATIONAL CHECKS



**Before operating the trailer, look in all directions and make sure no bystanders, especially small children are in the work area.**

Adjust and lubricate equipment as needed. (See Inspection on page 26.) & (See 7.1 LUBRICATION on page 25.)

## 5.4 TRANSPORTING



### CAUTION

#### AVOID SERIOUS INJURY OR DEATH

- Read and understand owner's manual before using. Review safety precautions annually.
- Before operating the trailer, look in all directions and make sure no bystanders, especially small children are in the work area.
- No riders allowed when transporting.
- Do not drink and drive.
- Before moving, be sure required lights and reflectors are installed and working.
- Before maintenance or repair, stop vehicle, set parking brake, and remove ignition key.
- Place safety stands under frame and chock wheels before working on tires or chassis.
- Maintain wheel bolts at torque as recommended in the manual.
- If equipped with brakes, maintain proper adjustment.



### CAUTION

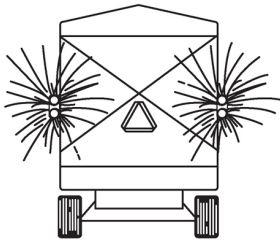

#### Pull-Type Units

- Use flashing warning lights when transporting on ALL highways (public roadways) at ALL times (Tractor towed models) EXCEPT WHEN PROHIBITED BY LAW! (Check w/local law enforcement)
- By all state and federal laws, implement lights do not replace the SMV (Slow-Moving Vehicle) identification emblem. All towed agricultural vehicles must display SMV emblems when traveling LESS than 20 mph (32 kph).
- Check for traffic constantly. Be sure you can see that no one is attempting to pass you and that all traffic is sufficiently clear from you before making any turns.
- Securely attach to towing unit. Use a high strength appropriately sized hitch pin with mechanical retainer and attach safety chain.
- Do not exceed 20 mph (32 kph). Slow down for corners and rough terrain.



### WARNING



#### To Prevent Serious Injury Or Death

- Keeps hands and body out of the hitch area when attaching towing vehicle.
- Keep body clear of crush point between towing vehicle and load.
- Keep hands, legs and feet from under tongue and hitch until jack is locked into place.



### WARNING

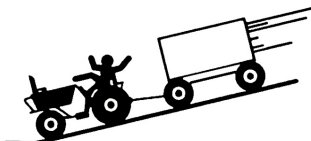

#### To Prevent Serious Injury Or Death

- Shift to lower gear before going down steep grades.
- Avoid traveling on slopes or hills that are unsafe.
- Keep towing vehicle in gear at all times.
- Never exceed a safe travel speed (which may be less than 20 MPH.).

## WARNING

You must observe all applicable traffic laws when transporting on public roadways. Check local laws for all highway lighting and marking requirements. Failure to heed may result in serious personal injury or death.

## WARNING

(Tractor Powered) Do not tow at speeds in excess of 20 mph. Failure to heed may result in serious personal injury or death.

## CAUTION

Surge brakes are to be used for assisting in stopping **ONLY** and are not to be relied on as the only means for stopping the towed piece of equipment.

## IMPORTANT

Trailer is to be used for agriculture use only. Travel only at tractor speeds.

## IMPORTANT

If you will travel on public roads and it is legal to do so, you must know all rules governing such operation. This will include lighting and brake requirements in addition to traffic rules.

**NOTE:** An Optional Highway Lighting Package is available to assist in meeting these requirements. See your Meyer Dealer for Details.

### 5.4.1 Safety Chain

## WARNING

A safety chain must be installed to retain the connection between the tractor (or other towing vehicle) and implement whenever traveling on public roads in case the hitch connection would separate.

The chain must be of adequate size to hold the weight of the loaded trailer.

**NOTE:** If using a grab hook at the end(s) of the chain to secure the chain to itself, a hook latch (Item 1) must be installed.

The length of the safety chain is not to be any longer than necessary to turn without interference. If any chain links or attachment hardware are broken or stretched, repair before using. Store chain so it does not corrode or become damaged. Do not use this chain for other implements because the strength and length of the chain may not be adequate. Identify this chain for use on this particular trailer.

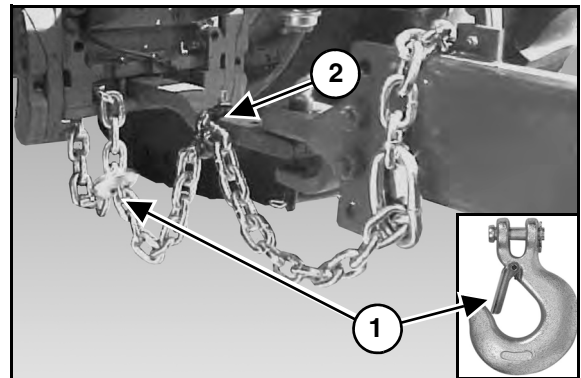

**NOTE:** Do not use the intermediate support (Item 2) as the attaching point.

## IMPORTANT

If you do not have a safety chain, or a replacement safety chain is needed, see your local Meyer dealer and do not operate on public roads until you are able to travel with the safety chain properly installed.

## 5.4.2 Trailer Brake System (Optional)

**IMPORTANT**

Surge brakes are to be used for assisting in stopping **ONLY** and are not to be relied on as the only means for stopping the towed piece of equipment.

**IMPORTANT**

Before towing, check that the brake fluid reservoir is maintained to at least half full. If not refill with DOT 3 brake fluid. Check complete system for any leaks and repair as needed.



**CAUTION**

The safety break-away chain is not to act as a parking brake.

A brake system is recommended for any trailer operated on public roads and may be a requirement. Before using any equipment equipped with brakes, the operation of the brakes should be checked. During travel, attention should be paid to how the brakes are functioning and any necessary adjustments should be made. It will be necessary to check the brake lines and brake linings for wear. Brake linings should be replaced before the rivets or support plates come in contact with the wheel drum. Make all necessary maintenance before using equipment.

Connect the breakaway chain from the actuator to the tow vehicle fastening to the bumper or hitch assembly. Allow extra slack for turning corners, but not too much slack for the chain to be dragging on the pavement. Maintain as straight a connection to the tow vehicle as possible. The safety break-away chain will only function after the hitch pin and safety chains have failed.

The brake actuator has an emergency lever attached to a chain which is attached to the tow vehicle during use. In the event of the towed trailer becoming detached from the towed vehicle, the chain will pull forward and lock the brakes to stop the travel of the trailer. The lever will have to be manually released to disengage the brakes. A lever guide bracket is located on the top of the actuator with a decal to show the brake on and brake off position. If the trailer is towed with the brake lever lock in the brake on position, damage to the brakes will result.

Trailers with free backing brakes will not hold in reverse direction. To release the break-away lever, pull forward on the break-away lever, pry up on the spring clip then release the break-away lever.

Examine actuator for bent parts or excessive wear. Straighten or replace any worn parts as needed. Check to see that all mounting bolts and fasteners are tight.

For additional information, visit [www.demco-products.com](http://www.demco-products.com). Click the "Service & Support" tab, followed by "Owner Manuals". In the search bar, type "BH20023" for the brake actuator DA91 or type "BC20011" for free backing brakes, 13" x 2-1/2".

## 5.4.3 Tractor Towing Size Requirements

The minimum tractor weight, up to 20 mph (32 kph) needs to be two thirds of the box gross weight (GW). Gross weight is calculated by the empty weight of the mounted implement and undercarriage combined added to the load weight. Then take the gross weight and multiply it by 0.667 and you will get the minimum required weight of the tractor.

Gross Weight

<b>MODEL</b>	<b>MAXIMUM GROSS WEIGHT (LBS)</b>	<b>MINIMUM TRACTOR WEIGHT UP TO 20 MPH (LBS)</b>
XT16-162	32,000	21,500
XT16-202	32,000	21,500
XT22-216	44,000	30,000
XT22-240	44,000	30,000
XT22-264	44,000	30,000

<b>MATERIAL ESTIMATED WEIGHT PER CUBIC FOOT</b>	
<b>MATERIAL</b>	<b>LBS / CU. FT.</b>
Soybeans	47 lbs.
Cotton Seed (Dry)	20 lbs.
Corn (Shelled)	45 lbs.
Corn Silage	30 lbs.
Haylage	20 lbs.
Sawdust	17 lbs.

## 6.0 OPERATION



### CAUTION

DO NOT allow anyone to operate, service, inspect or otherwise handle this trailer until all operators have read and understand all of the instructional materials in this Operator's And Parts Manual and have been properly trained in its intended usage.

Before operating the trailer, look in all directions and make sure no bystanders, especially small children are in the work area.

Do not climb or step on any part of the trailer at any time.

Turn on level ground. Slow down when turning.

Go up and down slopes, not across them.

Keep the heavy end of the machine uphill.

Do not overload the machine.

Check for adequate traction.

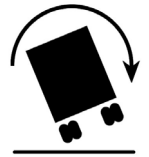

### CAUTION

Shutoff and lockout power before adjusting, servicing, maintaining, or clearing an obstruction from this machine. Failure to heed may result in serious personal injury or death.

### IMPORTANT

Overloading may cause failure of axles, tires, structural members, hitches, loss of vehicle control. **DO NOT** exceed maximum gross weight. (See 9.0 SPECIFICATIONS on page 65.)

### IMPORTANT

Loading the trailer evenly from the front to rear will ensure there is downward force on the tractor hitch and provide traction for the tractor wheels.

**NOTE:** Overloading can have detrimental effects on the integrity of the implement and it's safe use. Some materials such as soybeans may not be able to be filled to struck level. Overloading will void warranty and increase risk to the operator's safety. Always be aware of your gross weight.

### 6.1 UNHOOKING THE TRACTOR

1. Park the implement on level ground. Put the tractor controls in neutral, set the parking brake, and turn the engine off before dismounting.
2. Place wheel chocks in front and in back of the implement wheels on opposite sides to prevent the implement from rolling after the tractor is unhooked.
3. Remove the light cords and any optional equipment connections.
4. Remove the jack from the storage mount and install it on the hitch tongue. Crank the jack down until the hitch lifts off the tractor draw bar.



### WARNING

Jack may not be designed to support the implement when it is loaded.

5. Remove the hitch pin.
6. Unhook safety chain from tractor drawbar and intermediate support.
7. Slowly drive the tractor away from the implement.





## 7.0 MAINTENANCE



Before servicing this equipment, ensure that all personnel, including family members are familiar with the equipment and the safety hazards that are present, along with the safety practices that should be observed while working in this equipment.



Before servicing or inspecting this trailer, have it hitched to a tractor with engine off, keys removed and parking brake set or chock all four wheels of trailer.

**IMPORTANT**

Fluid such as hydraulic fluid, grease, etc. must be disposed of in an environmentally safe manner. Some regulations require that certain spills and leaks on the ground must be cleaned in a specific manner. See local, state and federal regulations for the correct disposal.

### 7.1 LUBRICATION

**NOTE:** Use a grease type that is composed of a high quality lithium complex or better, unless otherwise stated. We recommend using a #1 grade in colder temperatures or a #2 grade in warmer temperatures.

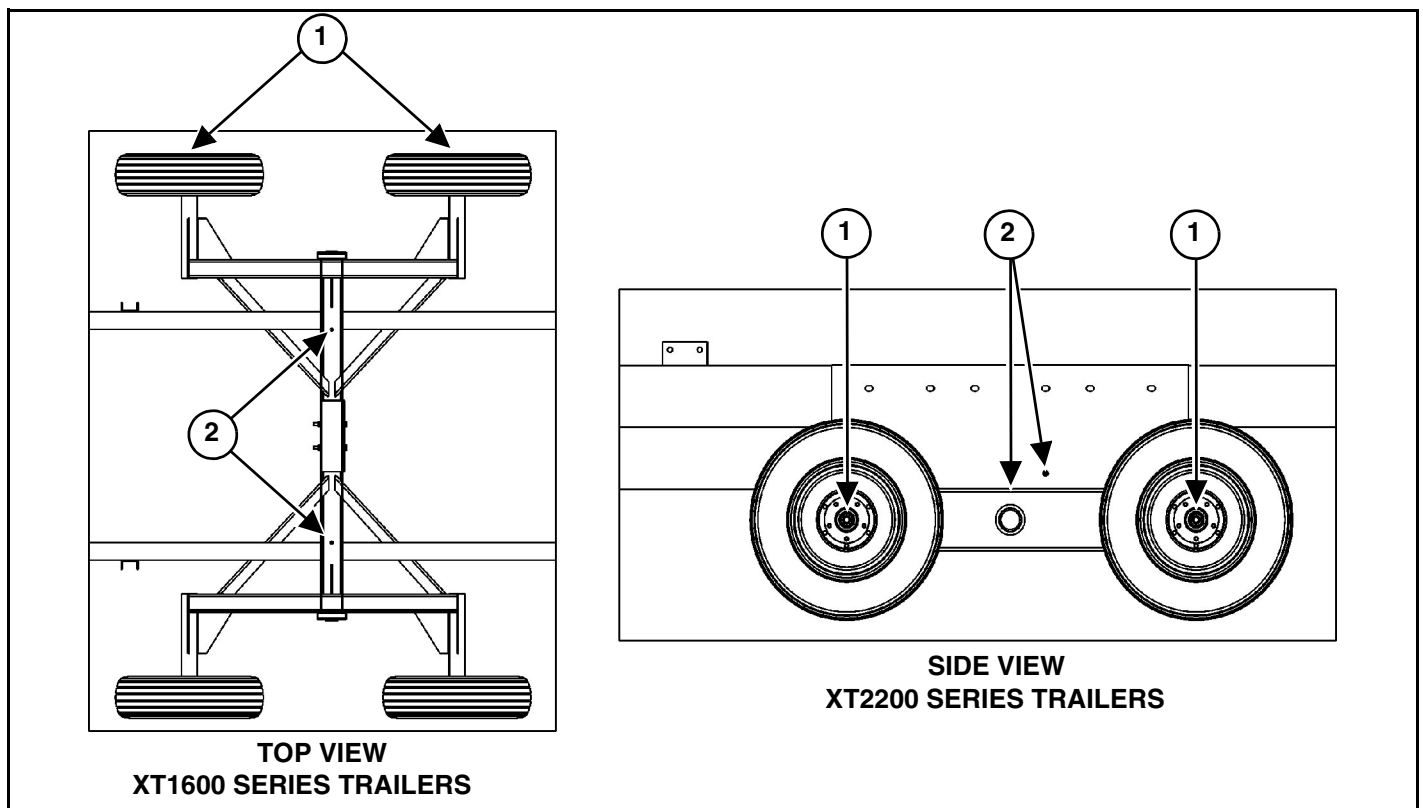

**DAILY** or every 8 - 10 loads:

- Grease the hubs (Item 1) (both sides).

**EVERY TWO WORK DAYS** or every 20 loads:

- Grease the tandem wings (Item 2) (both sides).

**NOTE:** Jack up empty trailer off ground and support on adequate jack stands to relieve pressure and grease until it purges.

## Inspection

### Daily or every 8-10 loads:

- Check wheel hub lug bolts for proper torque. See page 26.
- Check wheel hub bearings for play. Adjust bearing preload if required. (See 7.2.1 Adjust Wheel Bearing Preload on page 26.)
- Check tires for proper inflation. See page 29.

### Monthly or every 100-150 loads:

- Check trailer for loose and fatigued fasteners. Check all pivots for play. Tighten or replace as required.

### Annually:

- Check tires for wear and replace when necessary.
- Check all pivots and bushings for wear and repair as required.

#### 7.1.1 Pack Wheel Bearings

1. Chock all four wheels or hitch to tractor with engine off, key removed and parking brake set. Jack empty trailer off ground and support with adequate jack stands.
2. Disassemble hub and remove all old grease. Clean bearings in non flammable solvent and dry.
3. Reassemble hub and pack with quality wheel bearing grease.
4. Adjust wheel bearing preload as described in the following instructions.

## 7.2 ADJUSTMENTS

### 7.2.1 Adjust Wheel Bearing Preload

1. Chock all four wheels or hitch to tractor with engine off, key removed and parking brake set. Jack empty trailer off ground and support with adequate jack stands.
2. Push back and forth on each wheel assembly. If play is detected, bearings need adjusting.
3. If adjusting bearings, it is suggested the bearings be repacked as described previously.
4. Remove hub cap and remove cotter pin from spindle nut.
5. Tighten spindle nut to remove all play. It should be snug and slight drag can be felt while rotating the wheel.
6. If the cotter pin hole in the spindle does not line up with the notch in spindle nut, back off the spindle nut only enough to line up. Reinstall cotter pin. If cotter pin is damaged, replace it.
7. Replace hub cap and lower wheel to the ground.

### 7.2.2 Wheel Torque Requirements

BOLT/STUD SIZE	SOCKET SIZE	PRESS FORMED WHEEL CENTER	BOLT TYPE	HEAVY DUTY WHEEL CENTER
5/8	15/16 1-1/16	100 ft lbs	Bevel or Flange Nut	160 ft-lb
3/4	1-1/8 / 1-1/2	N/A	Flange Nut	378 ft-lb

### 7.2.3 Brakes (Optional)

## IMPORTANT

Before using any equipment equipped with brakes the operation of the brakes should be checked. Brake linings should be replaced before the rivets or support plates come in contact with the wheel drum. Perform all necessary maintenance before using equipment.



## WARNING

Any corrosive materials (saltwater, fertilizers) are destructive to metals. To properly maintain the life of the brake system flushing with a high pressure water hose is recommended. After washing be sure to grease actuator bearings (slides) and oil all moving parts. At the end of season it is recommended that the brake drums be removed and cleaned inside. Repack wheel bearings being careful not to contaminate the brake system with grease. Readjust the brakes.

Check and test the brakes before intensive use and every three months thereafter. Check the brake wear and the clearance between the brake linings and the drum visually. It is probable that the linings are worn when the brake travel has increased significantly. If the linings are worn to the minimum thickness replace with new.

Check that the brakes are clean and clean them if necessary. Lubricate the brake cam shaft bearings with grease zerks. To prevent grease from getting on the brake drum or linings, do not over grease.

#### 7.2.3.1 Brake Adjustment

The brake adjustment nut is located through a slot at the bottom of the backing plate. Insert brake tool or screw driver into slotted hole with handle up and bit against the adjusting wheel, pull down on handle and rotate wheel while tightening. When you can no longer rotate wheel in the forward direction, then loosen the large nut on the back side of the brake cluster, located at the 12 o'clock position, one turn, do not take nut completely off, just loosen to allow anchor pin to realign. Take dead blow hammer and tap on brake drum several times around the perimeter. Now re-tighten the large anchor pin nut, and back off shoe adjuster 10-15 clicks. If there is one spot where the wheel drags just slightly this is acceptable. As soon as the brake linings are burnished (this requires several braking stops) the brakes will then be set correctly.

#### 7.2.3.2 Brake Bleeding

Before bleeding brakes fill the system with DOT 3 hydraulic brake fluid. Using a vacuum type brake bleeder (this type of brake bleeder is available at your local automotive store) follow manufacturer's directions for bleeding.

Install bleeder hose on first wheel cylinder to be bled, if tandem bleed rear axles first. Have loose end of hose submerged in a glass container of brake fluid to observe bubbling. By working the manual hand pump you will draw the air out of the brake lines filling it with fluid.

By loosening the bleeder screw located in the wheel cylinder one turn, the system is open to the atmosphere through the passage drilled in the screw. When the bubbling stops in the glass container close the bleeder screw securely. Follow the same procedure at each wheel cylinder being sure to maintain the master cylinder fluid level at least one half full of brake fluid. After all wheels are bled fill the master cylinder to 3/8" below the full level.

## 7.3 FARM IMPLEMENT TIRES

### 7.3.1 Service And Maintenance Tips

Agricultural tires are designed to carry a specified load at a specified inflation pressure when mounted on a specified width rim. When these conditions are met, the deflection of the tire carcass is in the optimum range and maximum tire performance can be expected. If this combination of design factors is altered for any reason, tire performance will be reduced.

Inflation pressures should be checked at least every week. Recommended inflation pressures based on total load on tires should be used. For accurate inflation use a special low-pressure gauge with one-pound gradations. Gauges should be checked occasionally for accuracy. Always use sealing valve caps to prevent loss of air.

#### *Tire Overload or Under Inflation*

Tire overload or under inflation have the same effect of over-deflecting the tire. Under such conditions the tread on the tire will wear rapidly and unevenly, particularly in the shoulder area. Radial cracking in the upper sidewall area will be a problem. With under inflated drive tires in high torque applications sidewall buckles will develop leading to carcass breaks in the sidewall. While an under inflated drive tire may pull better in some soil conditions, this is not generally true and not worth the high risk of tire damage that such an operation invites.

#### *Over Inflation*

Over inflation results in an under-deflected tire carcass. The tread is more rounded, concentrates tread wear at the centerline area. Traction is reduced in high torque service because ground contact of the tread shoulder area is reduced and the harder carcass, with reduced flexing characteristics, does not work as efficiently. The tightly stretched over-inflated carcass is more subject to weather checking and impact break damage.

#### *Pressure Adjustments Required - Slow Speed Operation*

Higher tire loads are approved for intermittent service operations at reduced speed. Under such conditions inflation pressure must be increased to reduce tire deflection and assure full tire service life. See Page 29 for proper inflation.

#### *Use of Proper Width Rims*

If tires are mounted on rims of incorrect width, the following conditions can result:

- Use of a wider rim results in flattening of the tread face. This feature may improve traction in loose soil conditions. In hard soils, however, the flatter tread penetrates less effectively and tractive effort is reduced. Additional stresses concentrated in the shoulder area tend to increase the rate of shoulder tread wear. By spacing the tire beads farther apart the sidewalls are forced to flex in an area lower than normal and this can result in circumferential carcass breaks and/or separation.
- Use of a narrower rim brings potential mounting problems because the rim shield or flange cover molded into most drive tire designs tends to interfere with the seating of the tire beads on a narrow rim. Once mounted on a narrow rim, the tire shield applies undue pressure on the rim flange, with possible tire sidewall separation or premature rim failure at the heel radius. On a narrow rim the tread of the tire is rounded. As with the over-inflated tire tread wear will be concentrated in the center area of the tread and traction in the field will be reduced.

### *Roading Of Farm Implement Tires*

- Tractor tires operate most of the time in field conditions where the lugs can penetrate the soil, and where all portions of the tread make contact with the ground. In operating on hard roads with low inflation pressure there is an undesirable distortion of the tire during which the tread bars squirm excessively while going under and coming out from under the load. On highly abrasive or hard surfaces, this action wipes off the rubber of the tread bars or lugs and wears them down prematurely and irregularly.
- Farm tractor and implement tires are designed for low-speed operations not exceeding 25 miles per hour. If tractors or implements are towed at high speeds on the highway high temperatures may develop under the tread bars and weaken the rubber material and cord fabric. There may be no visible evidence of damage at the time. Later a premature failure occurs which experience shows was started by the overheated condition that developed when the unit was towed at a high speed.

### *Care And Storage Of Tractor And Implement Tires*

- All tires should be stored indoors in a cool, dark, dry area free from drafts. Both heat and light are sources of oxidation on the tire surfaces - a result of which is crazing and weather checking. Tires should never be stored on oily floors or otherwise in contact with solvents, oil or grease. Further, tires should not be stored in the same area with volatile solvents. Such solvents are readily absorbed by rubber and will damage and weaken it.
- Tires should be stored away from electric motors, generators, arc welders, etc. since these are active sources of ozone. Ozone attacks rubber - to cause crazing and weather checking.
- Unmounted tires should be stored vertically on tread. If stored for an extended period, tires should be rotated periodically to reduce stress concentrations in the area of ground contact. Tires should not be stored flat and "stove piped" as they will become squashed and distorted, making mounting on the rim difficult - particularly for tubeless tires.
- Inflated tires mounted on rims should be stored under conditions noted above, with inflation pressure reduced to 10 PSI.

### **7.3.2 Tire Inflation**

<b>TIRE SIZE</b>	<b>PLY</b>	<b>PSI</b>
12.5L-15	8	36
12.5L-15	12	52
14L-16	12	44
16.5L-16	10	36
19LX16.1	10	32
21.5L-16.1	18	44
11R/22.5	used truck	75
425/65x22.5	used truck	75
550/45x22.5	20	58

If tires are to operate for any length of time on roads or other hard surfaces and the draft load is not great, it is advisable to increase the pressure in the tire to the maximum recommendation in order to reduce the movement of the tread bars that causes excessive wiping action.

## **7.4 STORING THE TRAILER**

Sometimes it may be necessary to store your Meyer trailer for an extended period of time. Below is a list of items to perform before storage.

- Thoroughly clean the equipment.
- Lubricate the equipment. (See 7.1 LUBRICATION on page 25.)
- Make appropriate adjustments to equipment.
- Inspect the hitch and all welds on the equipment for wear and damage.
- Check for loose hardware, missing guards, or damaged parts.
- Check for damaged or missing safety signs (decals). Replace if necessary.
- Replace worn or damaged parts.
- Touch up all paint nicks and scratches to prevent rusting.
- Place the equipment in a dry protected shelter.
- Place the equipment flat on the ground.

## **7.5 RETURNING THE TRAILER TO SERVICE**

After the Meyer trailer has been in storage, it is necessary to follow a list of items to return the equipment to service.

- Lubricate the equipment.
- Connect to a tractor and operate equipment, verify all functions operate correctly.

## 8.0 PARTS REPAIR AND REPLACEMENT

### 8.1 REPLACEMENT PARTS



Before servicing this equipment, ensure that all personnel, including family members are familiar with the equipment and the safety hazards that are present, along with the safety practices that should be observed while working in this equipment.



Inspect the chassis' axles, o-beams, spindles, tires, hitches & all safety shielding, safety signs and safety lighting regularly. These parts if not watched closely, could pose potential injury or death. If any part is found in need of repair, follow the SHUTOFF & LOCKOUT POWER recommendations and have qualified personnel repair immediately.

Any individual that will be adjusting, servicing, maintaining, or clearing an obstruction from this machine needs to ensure that this machine stays safely "OFF" until the adjustment, service, or maintenance has been completed, or when the obstruction has been cleared, and that all guards, shields, and covers have been restored to their original position. The safety of all individuals working on or around this machine, including family members, are affected. The following procedure will be referred to throughout this manual, so be familiar with the following steps.

#### 8.1.1 Shutoff & Lockout Power Recommendations

##### 1. Think, Plan and Check

- a. **Think** through the entire procedure and identify all the steps that are required.
- b. **Plan** what personnel will be involved, what needs to be shut down, what guards / shields need to be removed, and how the equipment will be restarted.
- c. **Check** the machine over to verify all power sources and stored energy have been identified including engines, hydraulic and pneumatic systems, springs and accumulators, and suspended loads.

##### 2. Communicate - Inform everyone involved, including those working on or around this machine, that work is being done which involves keeping this machine safely "OFF".

##### 3. Power Sources

- a. **LOCKOUT** - Shut off engines and take the key, or physically lock the start/on switch or control. Disconnect any power sources which are meant to be disconnected (i.e. electrical, hydraulic, and PTO of pull-type units).
- b. **TAGOUT** - Place a tag on the machine noting the reason for the power source being tagged out and what work is being done. This is particularly important if the power source is not within your sight and/or will need to be isolated for a longer period of time.

##### 4. Stored Energy - Neutralize all stored energy from its power source. Ensure that this machine is level, set the parking brake, and chock the wheels. Disconnect electricity, block moveable parts, release or block spring energy, release pressure from hydraulic and pneumatic lines, and lower suspended parts to a resting position.

##### 5. Test - Do a complete test and personally double check all of the above steps to verify that all of the power sources are actually disconnected and locked out.

##### 6. Restore Power - When the work has been completed, follow the same basic procedures, ensuring that all individuals working on or around this machine are safely clear of the machine before locks and tags are removed and power is restored.

## IMPORTANT

It is important that everyone who works on this equipment is properly trained to help ensure that they are familiar with this procedure and that they follow the steps outlined above. This manual will remind you when to Shutoff & Lockout Power.

At times parts on this implement will become worn or damaged. Performing repairs on this implement can pose a risk of injury including death. To reduce risk, the party that will be doing the repair should be very knowledgeable of the implement and the equipment that they will be using to do the repair.

- Review the repair so that a plan can be put together and the proper equipment can be used to repair this implement safely and correctly.
- Personal safety equipment may include items such as safety glasses, protective footwear, hearing protection, gloves, fire retardant clothes, etc.



## WARNING

### Crushing Hazard

Do Not work under suspended or blocked parts.



- The use of hoists and/or supports may be needed to handle heavy components.
- If the implement is being repaired in the field, make sure the parking brake of the tractor is engaged, the implement is on solid and level ground.
- Welding and torching should be done by properly trained individuals who have proven their skills.

## IMPORTANT

Call the factory for any additional details you may need to perform the repair. Some parts may come with instruction sheets to assist in the repair. Instructions sheets may be provided with your parts order. Otherwise, if available, instruction sheets can be e-mailed or faxed for your convenience. Call Meyer Manufacturing Corporation toll free at 1-800-325-9103 or email [parts@meyermfg.com](mailto:parts@meyermfg.com)

**NOTE:** Be environmentally friendly and dispose of any waste materials properly. Recycle when appropriate.





XT1600 SERIES FRAME AND O-BEAM  
(WITHOUT 5-POINT SCALE)

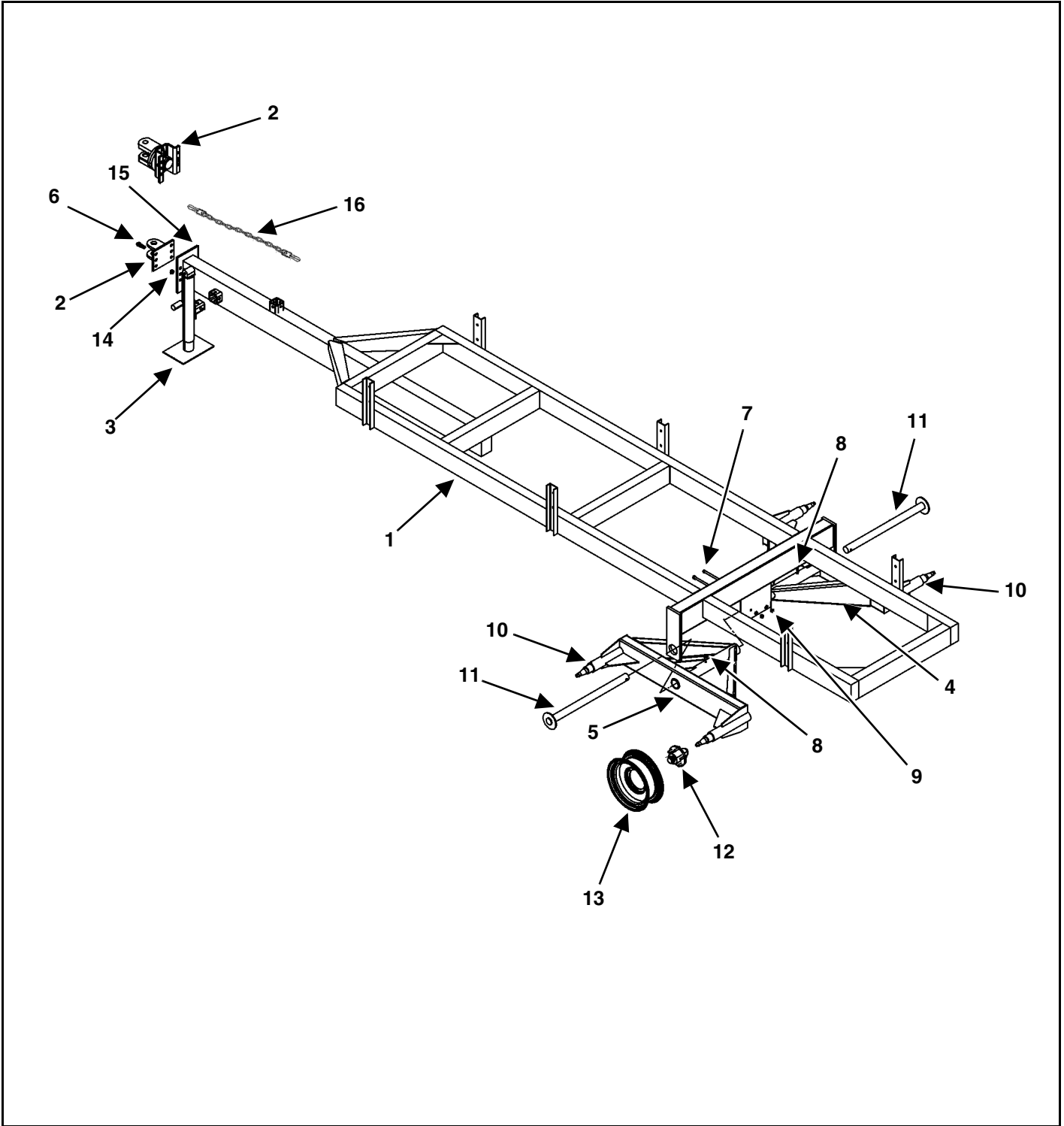

KEY	PART NUMBER	QTY	DESCRIPTION
1	Call 1-800-325-9103	1	Trailer Frame Assembly
2	75-0074	1	Bolt On Hitch
	75-2005	1	Optional Swivel Hitch
3	956-3803	1	Jack
4	75-1601	1	Right O-Beam Assembly Less Hubs
	75-1603	1	Right O-Beam Assembly W/Hubs
5	75-1602	1	Left O-Beam Assembly Less Hubs
	75-1604	1	Left O-Beam Assembly W/Hubs
6	881-6311-2Z	6	5/8"-11 x 2" Machine Bolt Grade 8 (Standard Hitch Only)
7	881-6311-5.5Z	2	5/8"-11 x 5-1/2" Machine Bolt Grade 8
8	30-0007	2	1/8" NPT x 45° Zerk
9	815-6311-Z	2	5/8"-11 Nylon Insert Locknut
10	75-0107	4	3" x 18-1/2" Straight Spindle
11	75-3005-1	2	Pivot Shaft Weldment
12	(See Page 50)	4	Hub
13	75-0255	AR	15 x 10" Wheel
	75-0253-HD	AR	16.1 x 11" Wheel
	75-0262-HD	AR	16.1 x 14" Wheel
	75-0268-HD	AR	22.5 x 8.25" Wheel
	75-0260	AR	22.5 x 13.5" Wheel
14	885-6311-Z	6	5/8"-11 Top Locknut Grade 8
15	901-3801-31	1	Adjustable Rear Hitch Mount Plate
16	52-0051	1	40,000# Capacity Safety Chain

**XT1600 SERIES FRAME AND O-BEAM  
(WITH 5-POINT SCALE)**

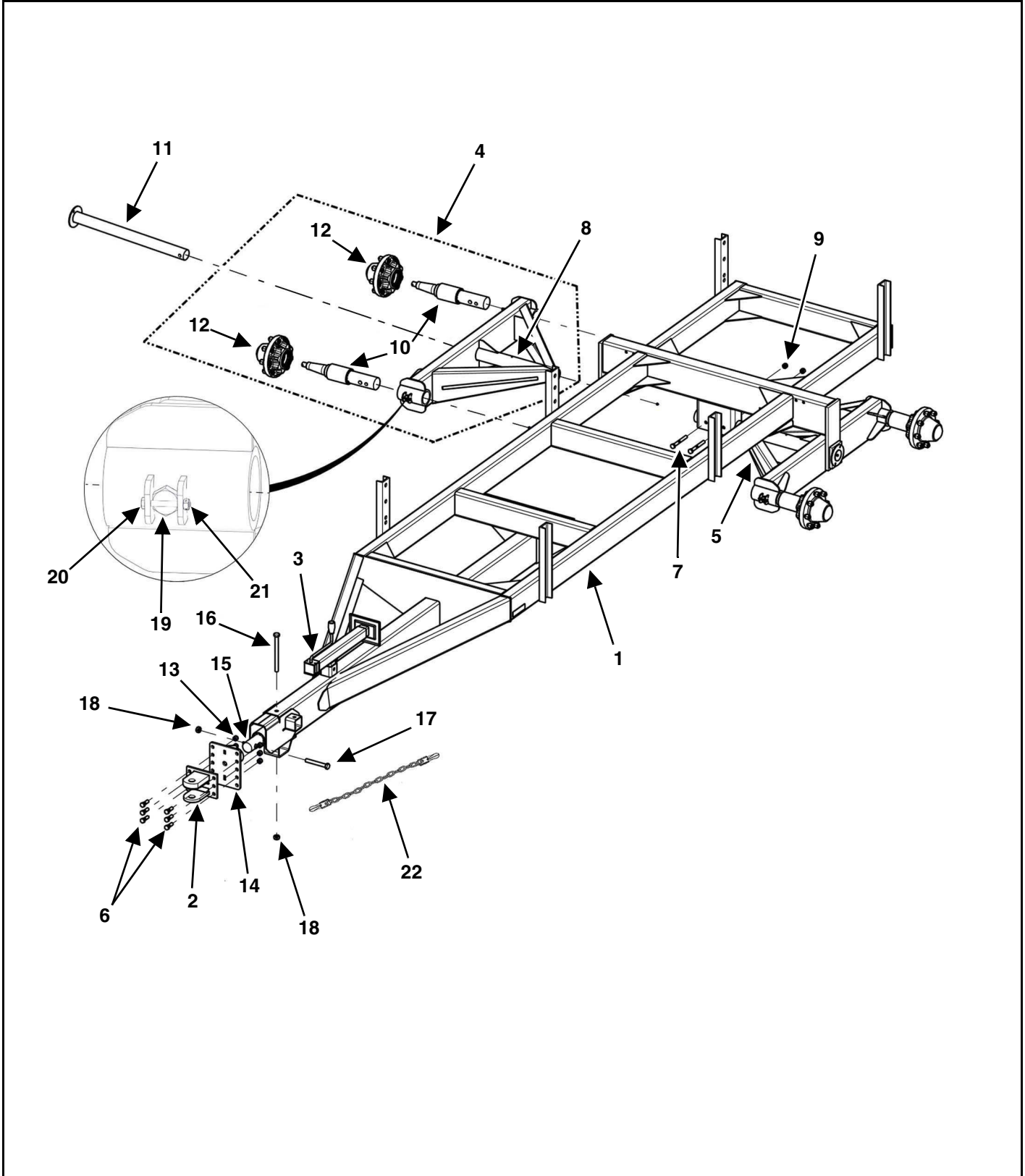

KEY	PART NUMBER	QTY	DESCRIPTION
1	Call 1-800-325-9103	1	Trailer Frame Assembly
2	75-0074	1	Bolt on Hitch
3	956-3803	1	Jack
4	75-1606-3-1	1	Right O-Beam Assembly Less Hubs
	75-1606-3	1	Right O-Beam Assembly W/Hubs
5	75-1606-2-1	1	Left O-Beam Assembly Less Hubs
	75-1606-2	1	Left O-Beam Assembly W/Hubs
6	851-6311-2Z	6	5/8"-11 x 2" Machine Bolt Grade 5
7	881-6311-5.5Z	2	5/8"-11 x 5-1/2" Machine Bolt Grade 8
8	30-0007	2	1/8" NPT x 45° Zerk
9	815-6311-Z	2	5/8"-11 Nylon Insert Locknut
10	75-0107	4	3" x 18-1/2" Straight Spindle
	58-0025	4	Spindle Load Cell
11	75-3005-1	2	Pivot Shaft Weldment
12	(See Page 50)	4	Hub
13	815-6311-Z	6	5/8"-11 Nylon Insert Locknut
14	75-1606-4	1	Hitch Mount Weldment
15	58-0023	1	Cell
16	881-7510-9Z	1	Cap Screw
17	881-7510-5.5	1	3/4"-10 x 5-1/2" GR8 MB
18	884-7510-Z	2	3/4"-10 Top Locknut GR8
19	881-7510-6Z	4	3/4"-10 x 6" Cap Screw
20	851-2520-2Z	4	1/4"-20 x 2" Machine Bolt Zinc
21	814-2520-Z	4	1/4"-20 Indented Locknut
22	52-0051	1	40,000# Capacity Safety Chain

**XT2200 O-BEAM  
SERIAL NUMBER DIRECTORY**

<b>2200 SERIES</b>	<b>SERIAL NUMBER RANGE</b>	<b>WITHOUT 5-POINT SCALE</b>	<b>WITH 5-POINT SCALE</b>
XT	Prior to SN 1822XT209	See Page 40	See Page 46
XTL/XTH	SN 1822XT209	See Page 42	See Page 48
XT	SN 1822XT210 - SN 1822XT261	See Page 40	See Page 46
XTL/XTH	SN 1822XT262 - SN 1822XT265	See Page 42	See Page 48
XT	SN 1822XT266 - SN 1822XT295	See Page 40	See Page 46
XTL/XTH	SN 1822XT296	See Page 42	See Page 48
XT	SN 1822XT297 - Prior to Model Year 2019	See Page 40	See Page 46
XTL/XTH	SN 1922XT201	See Page 42	See Page 48
XT	SN 1922XT202 - SN 1922XT219	See Page 40	See Page 46
XTL/XTH	SN 1922XT220 - SN 1922XT221	See Page 42	See Page 48
XT	SN 1922XT222 - SN 1922XT236	See Page 40	See Page 46
XTL/XTH	SN 1922XT237 - SN 1922XT240	See Page 42	See Page 48
XT	SN 1922XT241 - SN 1922XT244	See Page 40	See Page 46
XTL/XTH	SN 1922XT245 - SN 1922XT246	See Page 42	See Page 48
XT	SN 1922XT247	See Page 40	See Page 46
XTL/XTH	SN 1922XT248 - SN 1922XT251	See Page 42	See Page 48
XT	SN 1922XT252 - SN 1922XT255	See Page 40	See Page 46
XTL/XTH	SN 1922XT256 - SN 1922XT258	See Page 42	See Page 48
XT	SN 1922XT259	See Page 40	See Page 46
XTL/XTH	SN 1922XT260 - SN 1922XT261	See Page 42	See Page 48
XT	SN 1922XT262 - SN 1922XT264	See Page 40	See Page 46
XTL/XTH	SN 1922XT265 - SN 1922XT272	See Page 42	See Page 48
XT	SN 1922XT273 - SN 1922XT288	See Page 40	See Page 46
XTL/XTH	SN 1922XT289 - SN 1922XT292	See Page 42	See Page 48
XT	SN 1922XT293 - SN 1922XT294	See Page 40	See Page 46
XTL/XTH	SN 1922XT295 - SN 1922XT303	See Page 42	See Page 48
XT	SN 2022XT201	See Page 40	See Page 46
XTL/XTH	SN 2022XT202 - SN 2022XT207	See Page 42	See Page 48
XT	SN 2022XT208 - SN 2022XT211	See Page 40	See Page 46
XTL/XTH	SN 2022XT212 - SN 2022XT222	See Page 42	See Page 48
XT	SN 2022XT223 - SN 2022XT228	See Page 40	See Page 46
XTL/XTH	SN 2022XT229 - SN 2022XT236	See Page 42	See Page 48
XT	SN 2022XT237 - SN 2022XT238	See Page 40	See Page 46
XTL/XTH	SN 2022XT239 - SN 2022XT242	See Page 42	See Page 48
XT	SN 2022XT243 - SN 2022XT248	See Page 40	See Page 46
XTL/XTH	SN 2022XT249 - SN 2022XT252	See Page 42	See Page 48
XT	SN 2022XT253	See Page 40	See Page 46
XTL/XTH	SN 2022XT254 - SN 2022XT256	See Page 42	See Page 48
XT	SN 2022XT257 - SN 2022XT261	See Page 40	See Page 46
XTL/XTH	SN 2022XT262 - SN 2022XT268	See Page 42	See Page 48
XT	SN 2022XT269 - SN 2022XT270	See Page 40	See Page 46
XTL/XTH	SN 2022XT271 - SN 2022XT347	See Page 42	See Page 48

**XT2200 & XT2200+ SERIES FRAME  
(WITHOUT 5-POINT SCALE)**

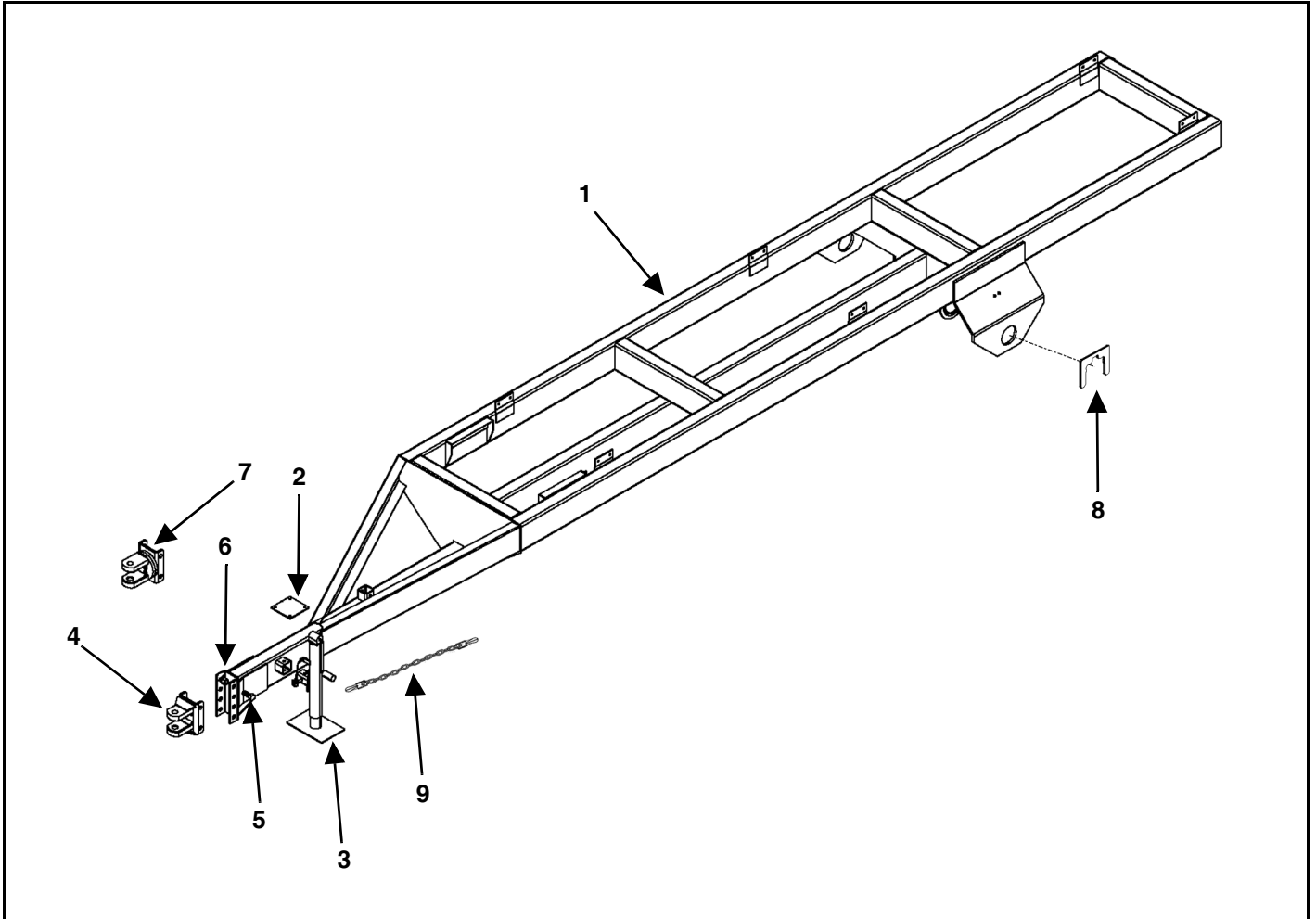

KEY	PART NUMBER	QTY	DESCRIPTION
1	Call 1-800-325-9103	1	Trailer Frame Assembly
2	75-2020	1	Plate, Brake Actuator Mount (Optional)
3	956-3803	1	Jack
4	75-0076	1	Clevis Hitch (Prior to SN 1422XT309)
	75-2023	1	Clevis Hitch (SN 1422XT309 & Later)
	75-2028	1	Bull Pull Hitch (SN 1422XT309 & Later)
5	881-1014-2.5Z	4	1" x 2-1/2" Machine Bolt Grade 8
6	884-1014-Z	4	1"-14 Top Locknut
7	901-3757	1	Swivel Hitch Assembly (Prior to SN 1422XT309)
	75-2024	1	Swivel Hitch Assembly (SN 1422XT309 & Later)
8	75-2404-2-1-9	2	Axle Center Pivot Locking Plate
9	52-0051	1	40,000# Capacity Safety Chain

OLD STYLE O-BEAM  
(WITHOUT 5-POINT SCALE)  
(APPLIES TO SN - SEE PAGE 38)

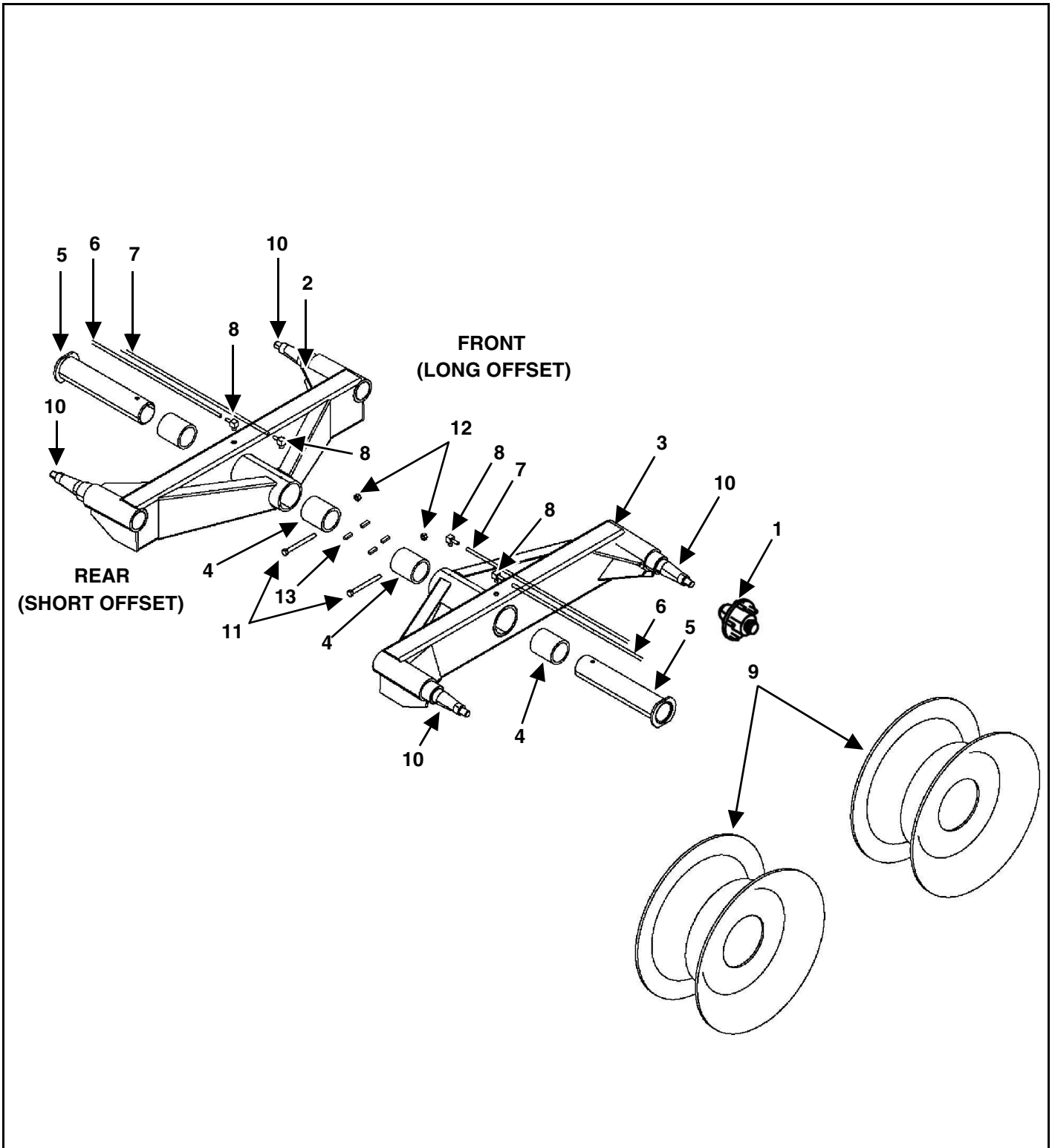



KEY	PART NUMBER	QTY	DESCRIPTION
1	See Page 51	4	Hub Assembly Complete 15,000#
2	901-8720-11-1	1	LH Tandem Wing Assembly, Less Hubs
	901-8720-11-1-B	1	LH Tandem Brake Wing Assembly, Less Hubs
3	901-8720-10-1	1	RH Tandem Wing Assembly, Less Hubs
	901-8720-10-1-B	1	RH Tandem Brake Wing Assembly, Less Hubs
4	901-8720-10-1-4	4	Nylon Pivot Sleeve
5	75-2404-2-2	2	Pivot Shaft Weldment (Prior to SN 1822XT300)
	75-2459	2	Pivot Shaft Weldment (SN 1822XT300 & Later)
6	955-3761	2	3/16" x 10" Grease Hose
7	955-3762	2	3/16" x 16" Grease Hose
8	30-0020	4	1/8" NPT Street L
9	75-0273	4	22.5 x 13 Wheel 0" Offset 425 Used Truck Tire
	75-0270	4	18 x 16.1 Wheel 21.5L Implement Tire
10	75-0115	4	3-1/2" x 23-1/2" Spindle Assembly
11	881-7510-8Z	2	3/4" x 8" Grade 8 Bolt
12	815-7510-Z	2	3/4" Nyloc Nut
13	901-8720-10-1-6	4	1/4" x 1/4" x 1" Key

**NEW STYLE O-BEAM  
(WITHOUT 5-POINT SCALE)  
(APPLIES TO SN - SEE PAGE 38)**

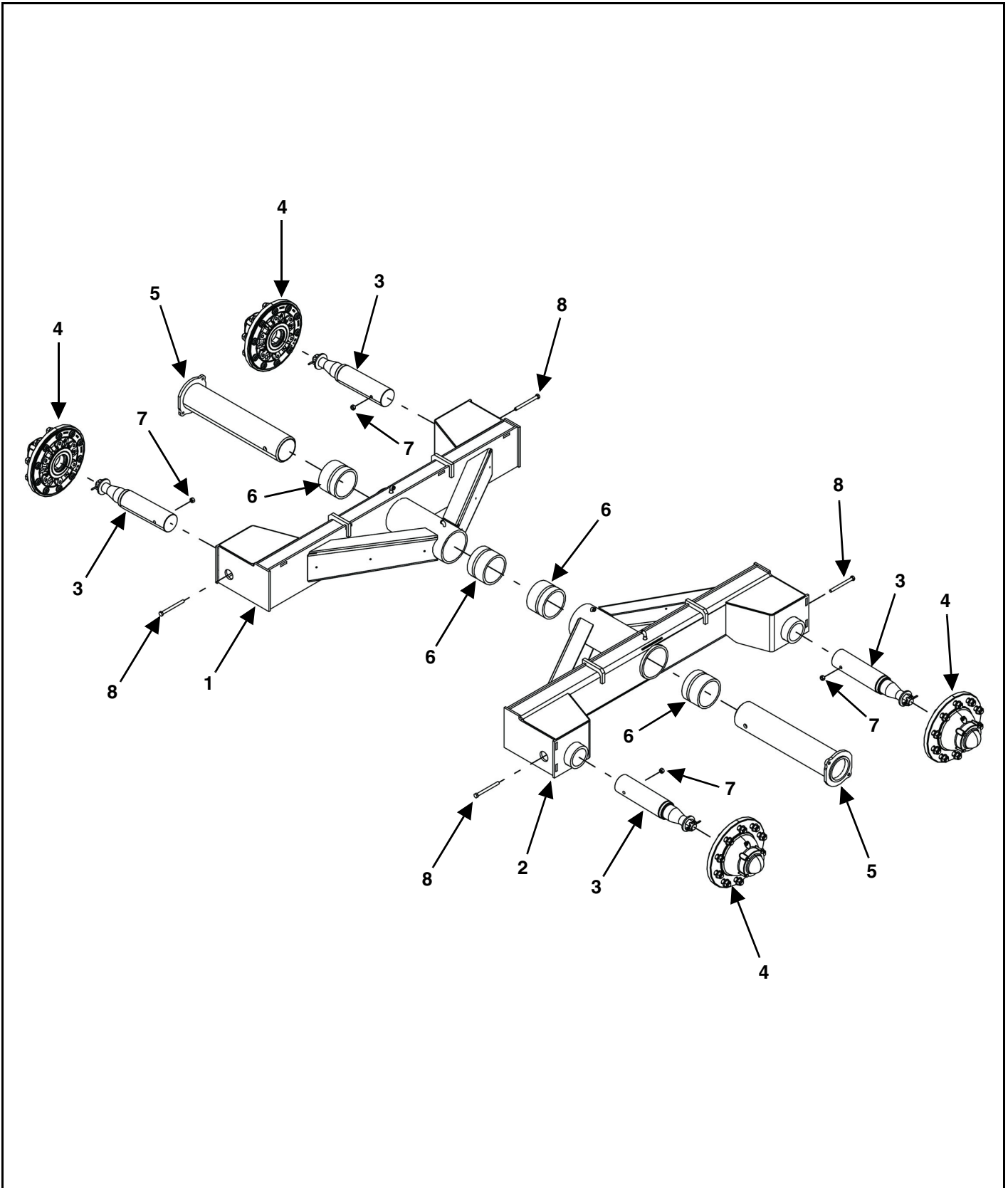

KEY	PART NUMBER	QTY	DESCRIPTION
1	75-2030	1	RH Tandem Wing Assembly Includes Axles & Hubs
	75-2030-NH	1	RH Tandem Wing Assembly Includes Axles
	75-2036	1	RH Tandem Wing Assembly Includes Axles, Hubs & Brake Drums (With Brakes)
	75-2036-NH	1	RH Tandem Wing Assembly Includes Axles (With Brakes)
	75-2030-NHS	1	RH Tandem Wing Weldment
2	75-2029	1	LH Tandem Wing Assembly Includes Axles
	75-2029-NH	1	LH Tandem Wing Assembly Includes Axles
	75-2035	1	LH Tandem Wing Assembly Includes Axles, Hubs & Brake Drums (With Brakes)
	75-2035-NH	1	LH Tandem Wing Assembly Includes Axles & Hubs
	75-2029-NHS	1	LH Tandem Wing Assembly Includes Axles
3	75-2029-2-AS	4	Spindle Assembly
	75-2029-3-AS	4	Spindle Assembly (With Brakes)
4	See Page 51	4	Hub
5	75-2459	2	Pivot Shaft Weldment
6	901-8720-10-1-4	4	Nylon Pivot Sleeve
7	814-5013-Z	4	1/2"-13 Center Lock Nut
8	881-5013-5.5Z	4	1/2"-13 x 5-1/2" Grade 8 Bolt

**XT2200 & XT/XTL/XTH2200+ SERIES FRAME  
(WITH 5-POINT SCALE)**

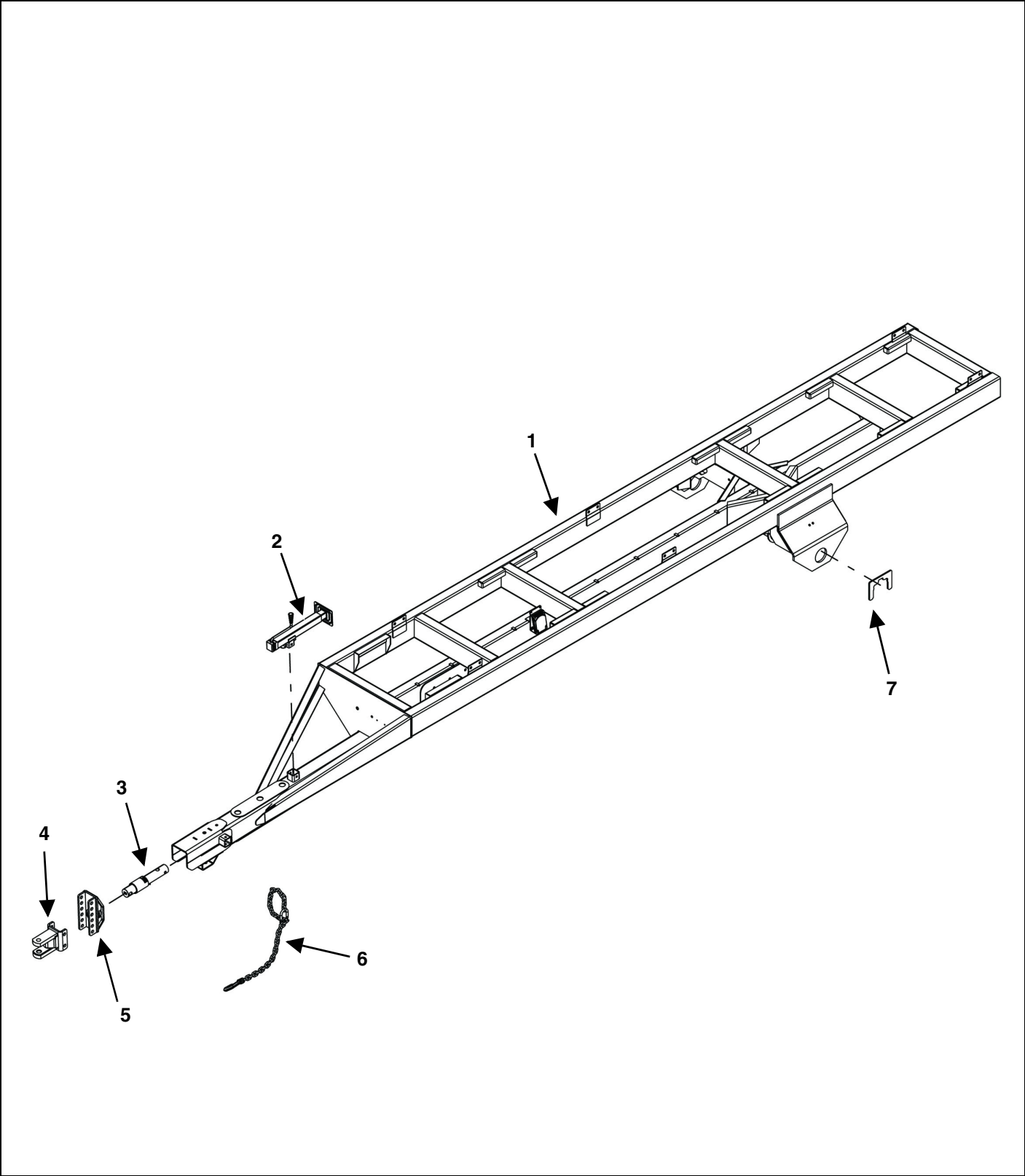

KEY	PART NUMBER	QTY	DESCRIPTION
1	Call 1-800-325-9103	1	Trailer Frame Assembly
2	956-3803	1	Jack
3	58-0024	1	Cell
	881-1008-9.5Z	1	9-1/2" Hex Head Cap Screw (Prior to SN 1622XT254)
	881-1008-10.5Z	1	10-1/2" Hex Head Cap Screw (SN 1622XT254 & Later)
4	75-2215	1	Clevis Hitch (Prior to SN 1422XT309)
	75-2023	1	Clevis Hitch (SN 1422XT309 & Later)
	75-2028	1	Bull Pull Hitch (SN 1422XT309 & Later)
5	75-4502-3	1	Hitch Assembly (Prior to SN 1422XT309)
	75-2027	1	Hitch Assembly (SN 1422XT309 & Later)
6	52-0051	1	40,000# Capacity Safety Chain
7	75-2404-2-1-9	2	Axle Center Pivot Locking Plate

OLD STYLE O-BEAM  
(WITH 5-POINT SCALE)  
(APPLIES TO SN - SEE PAGE 38)

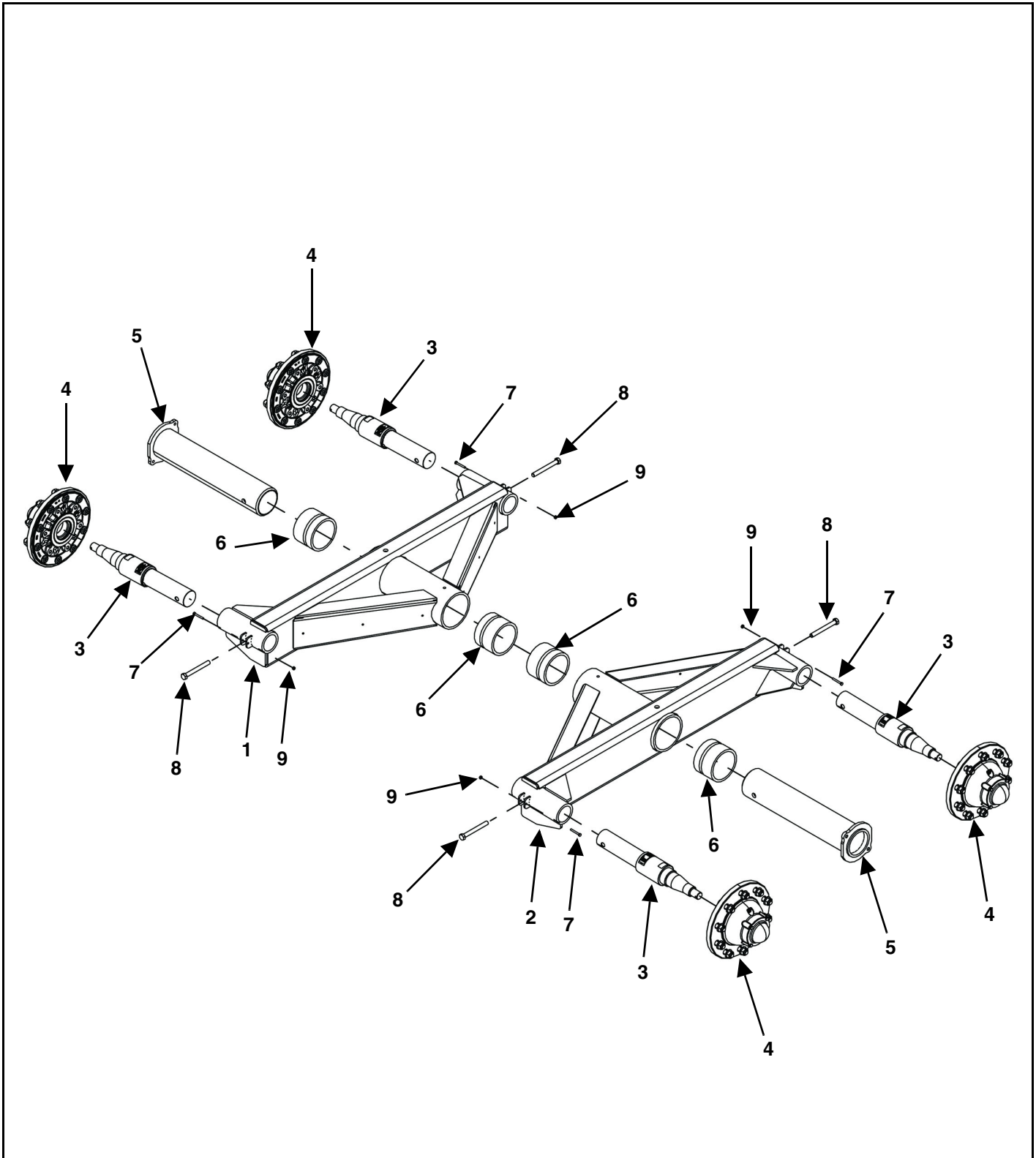

KEY	PART NUMBER	QTY	DESCRIPTION
1	75-2206-3	1	RH Tandem Wing Assembly Includes Axles & Hubs
	75-2206-3-1	1	RH Tandem Wing Assembly Includes Axles
2	75-2206-2	1	LH Tandem Wing Assembly Includes Axles & Hubs
	75-2206-2-1	1	LH Tandem Wing Assembly Includes Axles
3	58-0026	4	Spindle Assembly
4	See Page 51	4	Hub For XT2200 & XT/XTL/XTH2200+ Series
5	75-2404-2-2	2	Pivot Shaft Weldment (Prior to SN 1822XT300)
	75-2459	2	Pivot Shaft Weldment (SN 1822XT300 & Later)
6	901-8720-10-1-4	4	Nylon Pivot Sleeve
7	851-2520-2Z	4	1/4"-20 x 2" Machine Bolt
8	881-6311-5.5Z	4	5/8"-11 x 5-1/2" Machine Bolt Grade 8
9	814-2520-Z	4	1/4"-20 Indented Locknut

**NEW STYLE O-BEAM  
(WITH 5-POINT SCALE)  
(APPLIES TO SN - SEE PAGE 38)**

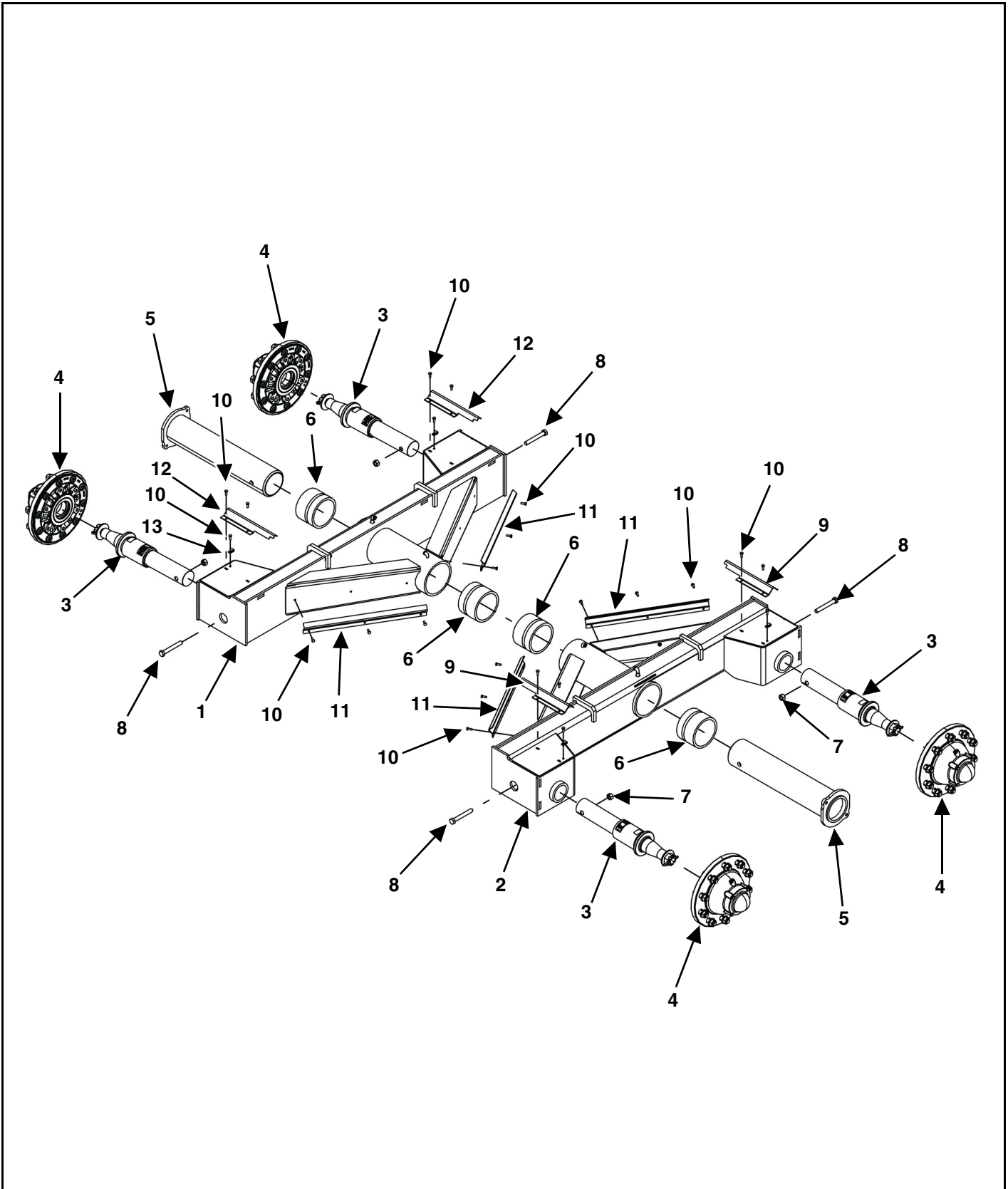



KEY	PART NUMBER	QTY	DESCRIPTION
1	75-2032	1	RH Tandem Wing Assembly Includes Axles & Hubs
	75-2032-NH	1	RH Tandem Wing Assembly Includes Axles
	75-2032-NHS	1	RH Tandem Wing Weldment
2	75-2031	1	LH Tandem Wing Assembly Includes Axles & Hubs
	75-2031-NH	1	LH Tandem Wing Assembly Includes Axles
	75-2031-NHS	1	LH Tandem Wing Weldment
3	58-0026-AS	4	Weigh Bar Spindle Assembly
4	See Page 51	4	Hub For XT2200 & XT/XTL/XTH2200+ Series
5	75-2459	2	Pivot Shaft Weldment
6	901-8720-10-1-4	4	Nylon Pivot Sleeve
7	886-6311-Z	4	5/8"-11 Center Lock Nut
8	881-6311-4.5Z	4	5/8"-11 x 4-1/2" Grade 8 Bolt
9	75-2031-2	2	Wire Cover
10	851-2520-.75Z	24	1/4"-20 x 3/4" Bolt
	810-2520-Z	24	1/4"-20 Spin Lock Nut
11	925-5021	4	Wire Protector Bracket
12	75-2031-3	2	Wire Cover
13	56-0053	4	1/4"- Vinyl Coated Steel Clamp

## HUB FOR XT1600 SERIES

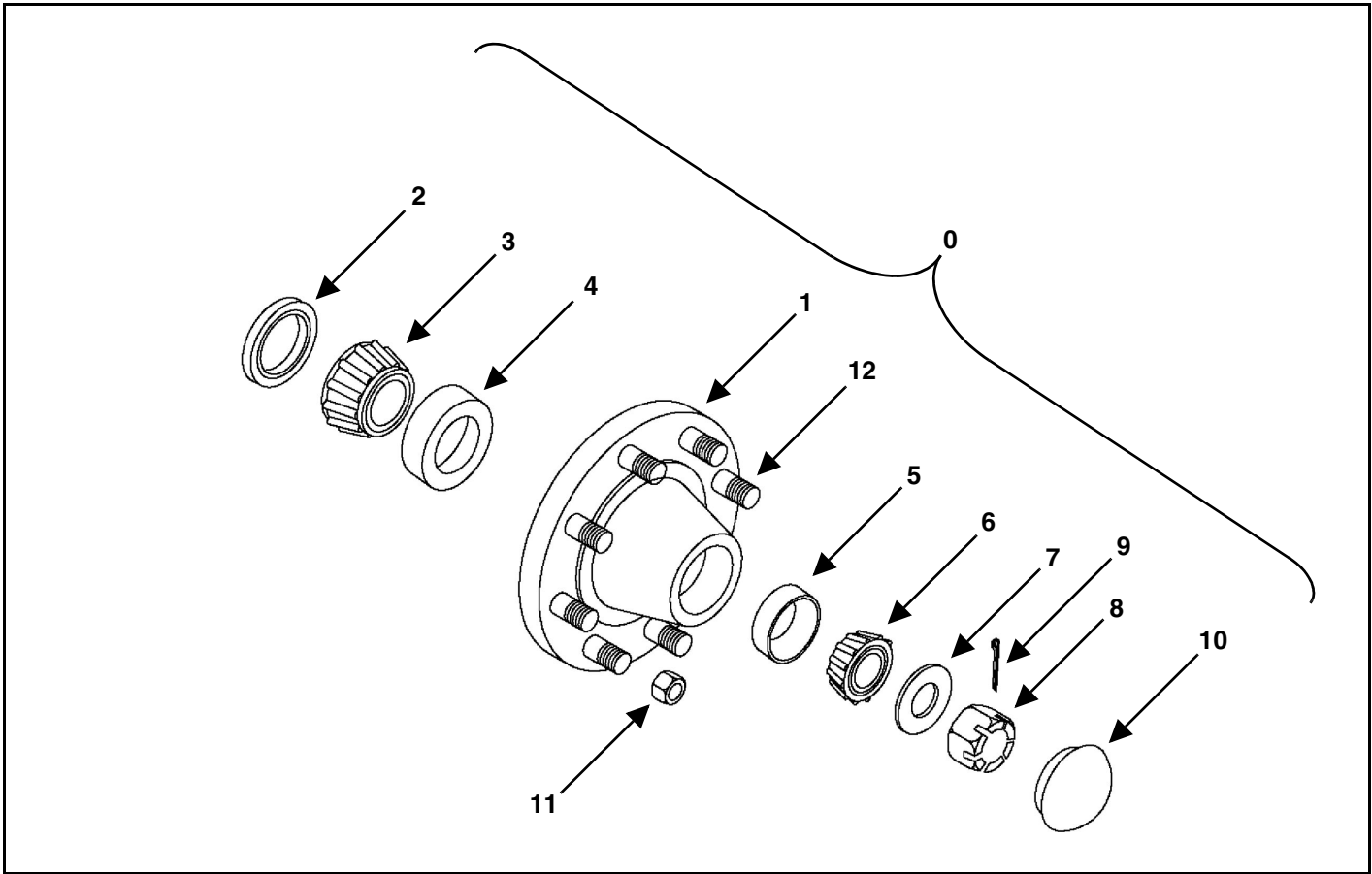

KEY	PART NUMBER	QTY	DESCRIPTION
0	75-0207	4	Hub Assembly Complete
	75-0207B	4	Brake Hub Assembly Complete
1	75-0207-1	1	Hub With Races & Studs
	75-0207-1B	1	Brake Hub With Races & Studs
2	75-0207-2	1	Grease Seal
3	75-0207-3	1	Inner Wheel Bearing
4	75-0207-4	1	Inner Wheel Race
5	75-0202-4	1	Outer Wheel Race
6	75-0202-3	1	Outer Wheel Bearing
7	75-0205-7	1	Washer
8	75-0205-8	1	Nut
9	75-0205-9	1	Cotter Pin
10	75-0205-10	1	Cap
11	75-0205-11	8	5/8"-18 Grade Lug Nut
12	75-0207-12	8	5/8"-18 x 2-1/2" Stud Bolt

HUB FOR XT2200 & XT/XTH/XTL2200+ SERIES

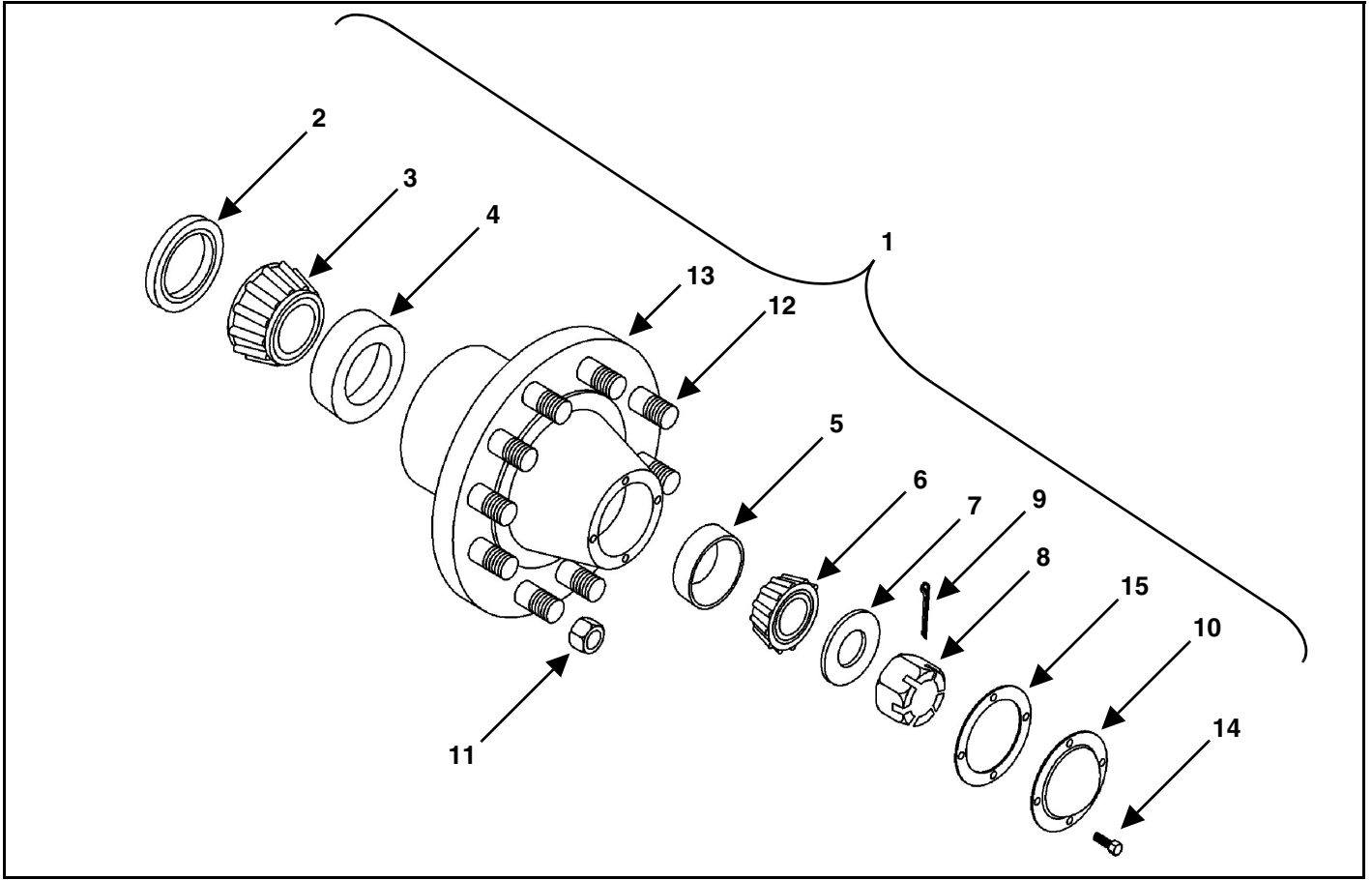

KEY	PART NUMBER	QTY	DESCRIPTION
1	75-0219	4	Hub Assembly Complete 15,000#
	75-0219-SC	4	Hub Assembly Complete 15,000# for Spindle Load Cell
2	75-0211-2	1	Seal
	75-0211-2-SC	1	Double Lip Seal for Spindle Load Cell
3	75-0211-3	1	Bearing Cone
4	75-0211-4	1	Bearing Cup
5	75-0208-5	1	Bearing Cup
6	75-0208-6	1	Bearing Cone
7	75-0208-7	1	Washer
8	75-0208-8	1	Nut
9	75-0208-9	1	Cotter Pin
10	75-0208-10	1	Hub Cap (Without Brakes: Prior to SN 2022XT266) (With Brakes: Prior to SN 2022XT207)
	75-0219-3	1	Hub Cap (Without Brakes: SN 2022XT266 & Later) (With Brakes: SN 2022XT207 & Later)
11	75-0208-11	10	3/4"-16 Grade Lug Nut - Flanged
12	75-0208-12	10	3/4"-16 Stud Bolt
13	75-0219-1	1	Hub Only W / Races & Studs
14	75-0208-13	1	Hub Cap Bolt
15	75-0208-14	1	Hub Cap Gasket (Without Brakes: Prior to SN 2022XT266) (With Brakes: Prior to SN 2022XT207)
	75-0219-2	1	Hub Cap Gasket (Without Brakes: SN 2022XT266 & Later) (With Brakes: SN 2022XT207 & Later)

# XT SERIES OPTIONAL SURGE BRAKE ACTUATOR ASSEMBLY

PRIOR TO SN 1422XT317

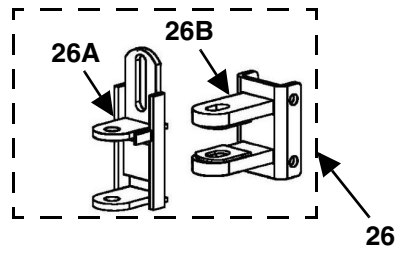

SN 1422XT317 & LATER

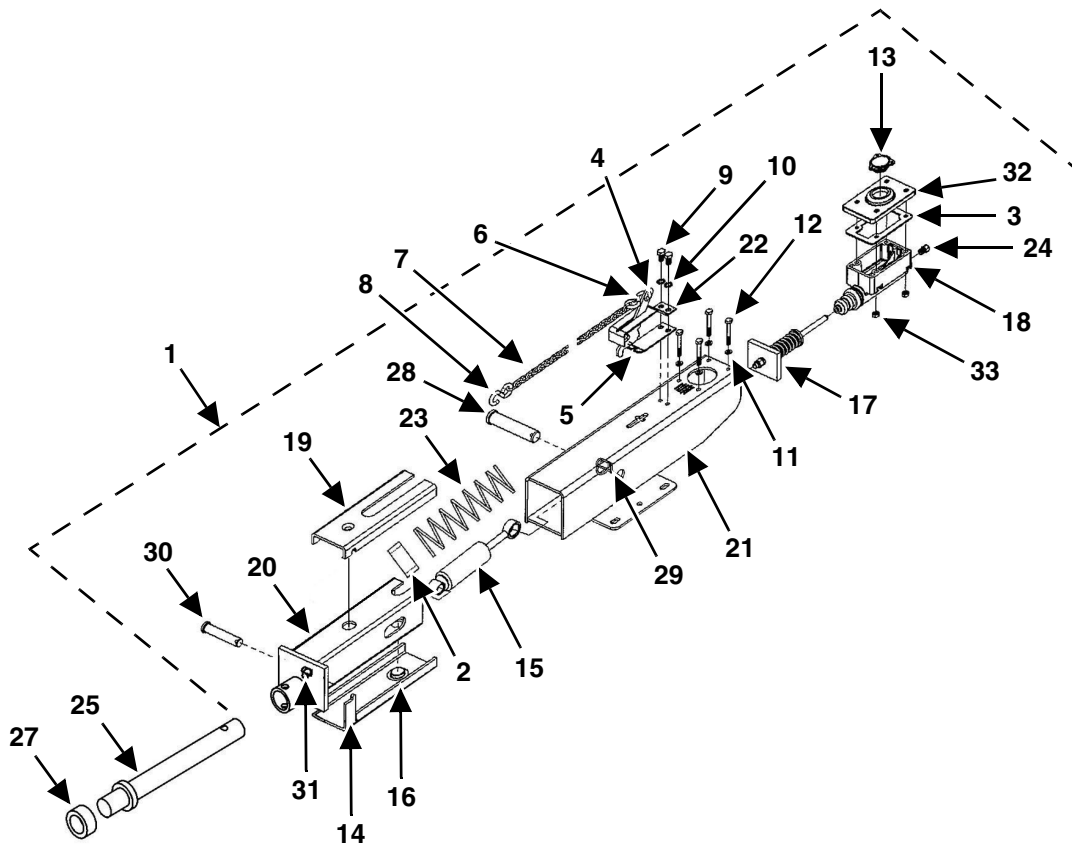
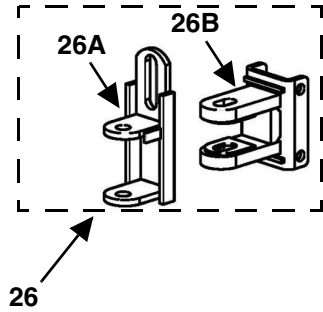

KEY	PART NUMBER	QTY	DESCRIPTION
1	57-0038	1	XT Trailer Optional Surge Brake Actuator Assembly
2	57-0029-1	1	Spring Spacer
3	57-0037-13	1	Master Cylinder Cork Gasket
4	57-0029-3	1	Safety Break-Away Lever
5	57-0029-4	1	Safety Break-Away Lock
6	57-0009-2	1	S-Hook (Heavy Stationary)
7	57-0030	1	Safety Break-Away Chain 96"
8	33-0032-1	1	S-Hook (Break-Away)
9	57-0029-5	2	5/16"-18 x 5/8" Machine Bolt Grade 5
10	57-0029-6	2	5/16" External Tooth Lock-Washer
11	822-0025-Z	4	1/4" Split Lock-Washer
12	851-3118-2Z	4	5/16"-18 x 2" Machine Bolt Grade 5
13	57-0037-12	1	Master Cylinder Cap Assembly
14	57-0037-5	2	Slide Spacer
15	57-0029-9	1	Damper Shock
16	57-0037-4	1	Slide Channel Bottom
17	57-0029-11	1	Push Rod Assembly
18	57-0029-12	1	Master Cylinder Assembly
19	57-0037-3	1	Slide Channel Top
20	57-0037-2	1	Inner Slide Tube
21	57-0037-1	1	Outer Case
22	57-0037-11	1	Emergency Lever Guide
23	29-0009	1	Spring
24	57-0029-17	1	Inverted Flare Fitting - Full Flow
25	75-2021-L	1	XT2200 Actuator Push Shaft Assembly
26	75-0077	1	XT2200 Brake Hitch Plate Weldment (Prior to SN 1422XT317)
	75-0078	1	XT2200 Brake Hitch Plate Weldment (SN 1422XT317 & Later)
26A	75-0077-2	1	Outer Brake Hitch Plate
26B	75-0077-1	1	Brake Hitch Plate (Prior to SN 1422XT317)
	75-2026	1	Brake Hitch Plate (SN 1422XT317 & Later)
27	921-0005	1	1-1/2" Set Collar
28	57-0037-6	1	Cold Headed Clevis Pin .875"
29	57-0037-7	1	Ring Lock Cotter 7/8" Shaft
30	57-0037-8	1	Front Shock Pin
31	57-0037-9	1	Ring Lock Cotter 5/8" Shaft
32	57-0037-10	1	Master Cylinder Cover
33	810-2520-Z	4	1/4"-20 Nut

XT SERIES OPTIONAL SURGE BRAKE ACTUATOR ASSEMBLY (CONT'D)

PRIOR TO SN 1422XT317

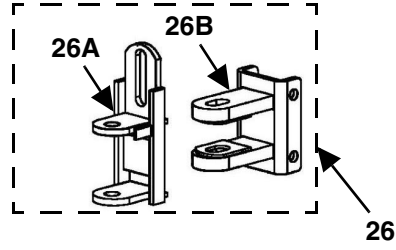

SN 1422XT317 & LATER

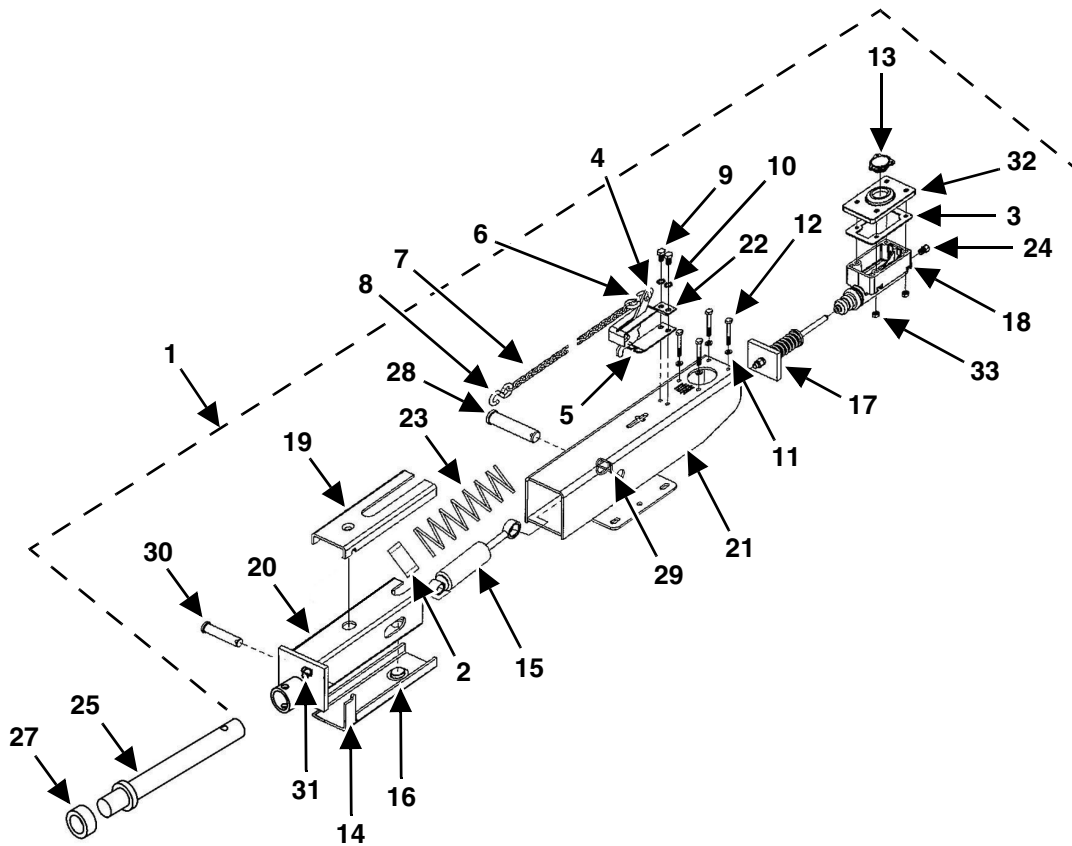
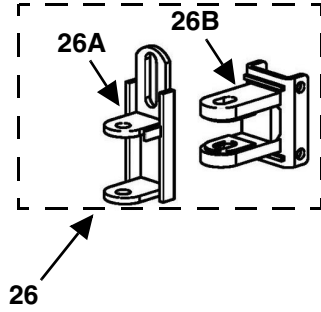

KEY	PART NUMBER	QTY	DESCRIPTION
NS	57-0029-18	1	1-1/4" Master Cylinder Repair Kit
NS	57-0029-19	1	Lever Replacement Kit (Including Key #'s 4 & 5)
NS	32-0024	AR	9/32" Brake line Loom Clamp
NS	57-0010	AR	18" Hydraulic Brake Hose
NS	57-0013	AR	Frame Tee W/Clip
NS	57-0014-2	AR	Brake Line Union
NS	57-0020	AR	90" Brake Line
NS	65-0006-5	AR	Nylon Tie Straps
NS	57-0017	AR	Frame Tee Plug
NS	75-0211-B	AR	XT2200 10 Bolt Brake Hub
NS	813-5020-Z	AR	1/2"-20 Nut Fine Thread Zinc
NS	822-0050-Z	AR	1/2" Split Lock-Washer
NS	825-25-1Z	AR	1/4" x 1" Self Tapping Screw
NS	851-5020-1Z	AR	1/2"-20 x 1" UNF Grade 5 Machine Bolt Zinc
NS	806-0050-Z	AR	1/2" Internal Tooth Lock-Washer Zinc
NS	33-1003	AR	Rubber Grommet
NS	57-0027	AR	48" Brake Line Assembly
NS	57-0033	AR	1/8" NPT Plug
NS	57-0041	AR	Cluster Mount Bracket
NS	57-0036	AR	224" Brake Line

**XTL2200+ AND XTH2200+ SERIES OPTIONAL SURGE BRAKE ACTUATOR ASSEMBLY**

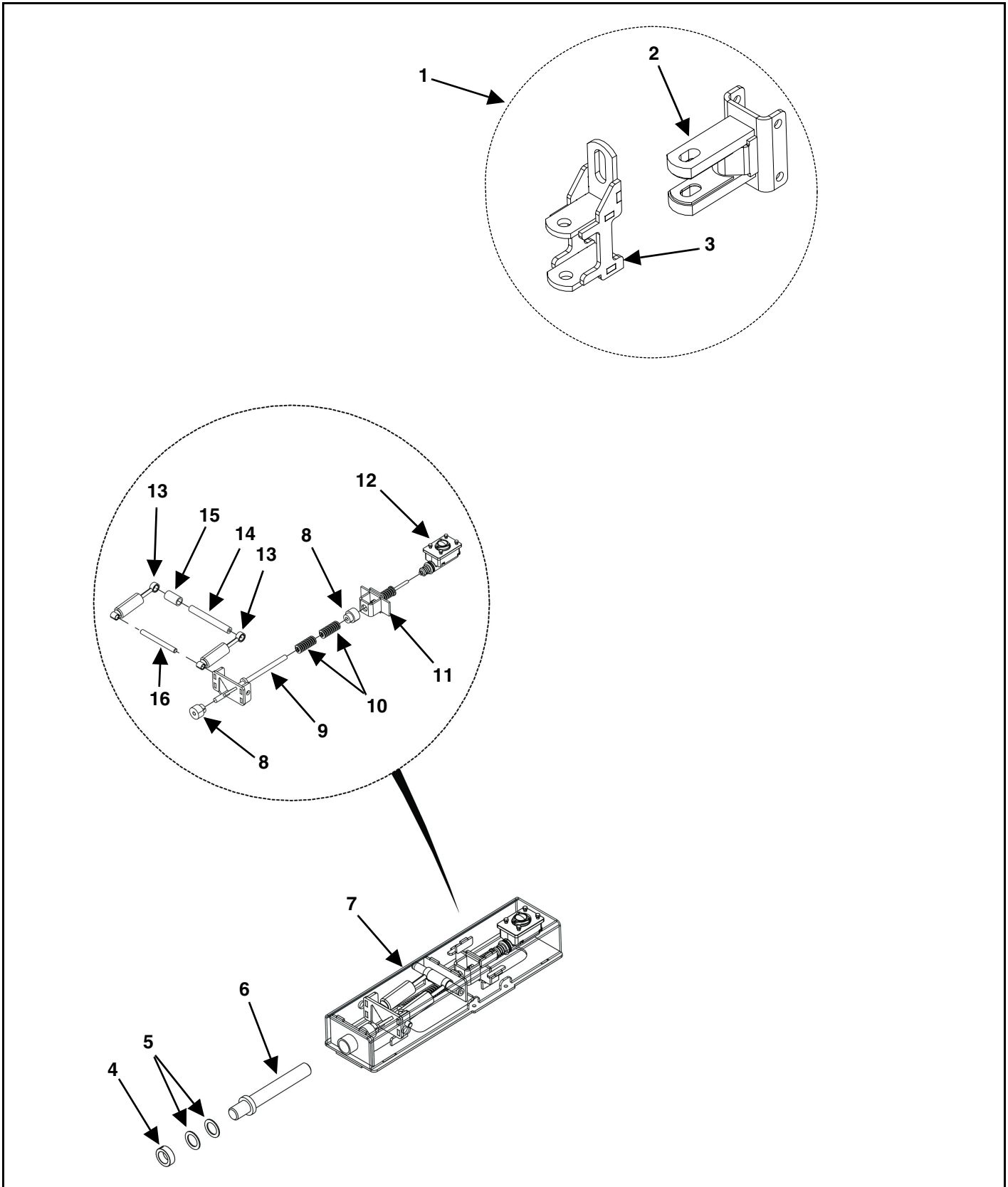



KEY	PART NUMBER	QTY	DESCRIPTION
1	75-2039	1	Surge Brake Clevis Assembly
2	75-2037	1	Clevis Weldment
3	75-2038	1	Push Plate Weldment
4	921-0005	1	1-1/2" Set Collar
5	75-2040-2	2	Surge Brake Washer
6	75-2040	1	Surge Actuator Push Rod Weldment
7	75-0158	1	Actuator Assembly
	75-0158-1	1	Actuator Enclosure Only
8	57-2000-2	2	Push Off Assembly Adjustment
9	57-2000-6	1	Brake Actuator Weldment
10	57-2000-3	2	Spring
11	57-2000-7-4B	1	Push Plate Assembly With Emergency Lever Plates
12	57-2000-4	1	Master Cylinder Assembly
13	57-0029-9	2	Damper Shock
14	75-5045-3	1	Inner Pole Shock Guide
15	75-5045-4	1	Inner Pole Shock Spacer Tube
16	57-2000-6-7	1	Brake Cylinder Mount Rod

XT/XTL/XTH SERIES OPTIONAL HAND/FOOT BRAKE CONTROL ACTUATOR ASSEMBLY

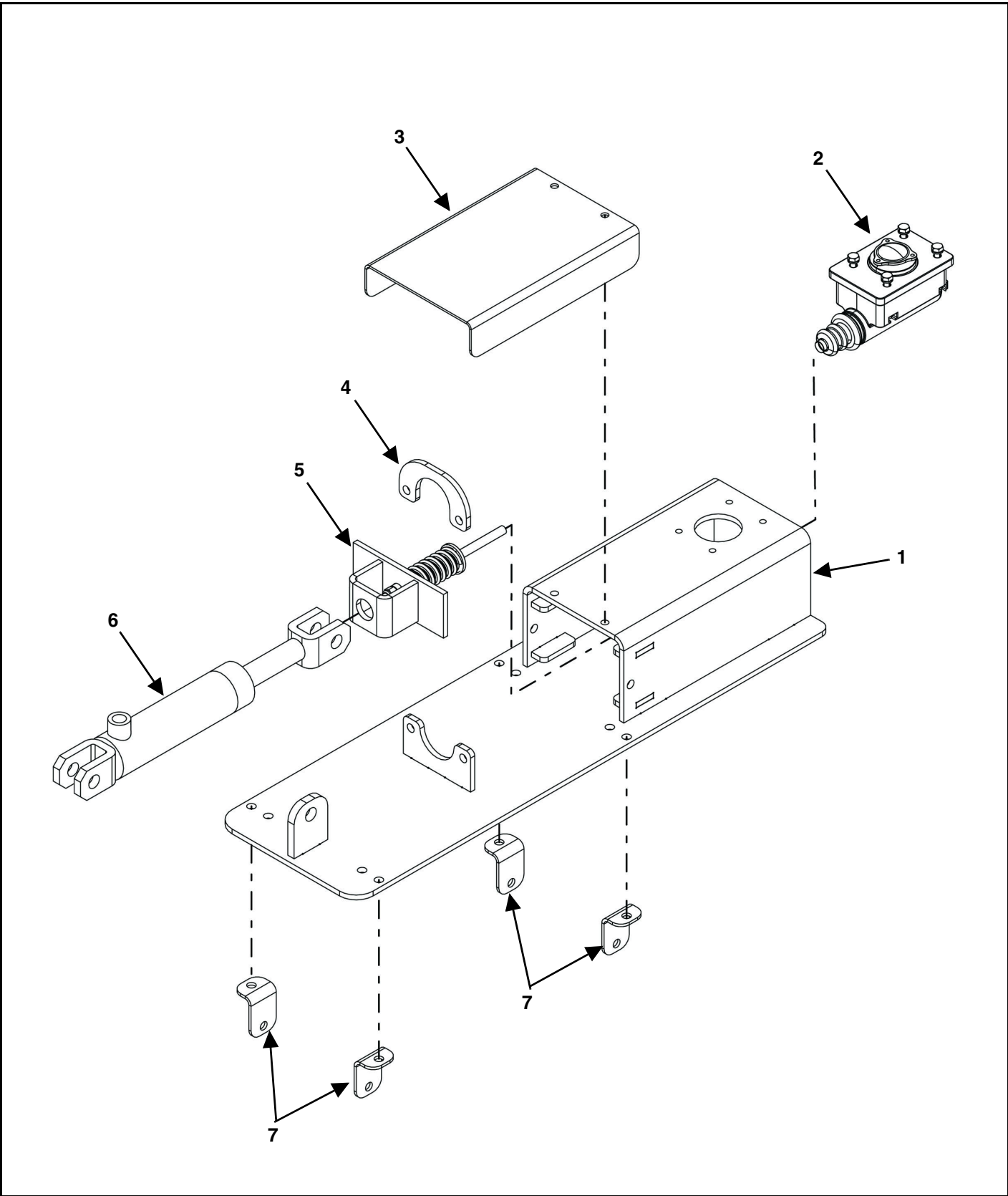

KEY	PART NUMBER	QTY	DESCRIPTION
0	75-2230	1	XT/XTL/XTH Trailer Optional Hand/Foot Control Brake Actuator Assembly
1	75-2230-1	1	Brake Actuator Mount Weldment
2	57-2000-4	1	Master Cylinder Assembly
3	75-2230-3	1	Brake Actuator Cover
4	75-2230-1-5	1	Brake Actuator Cylinder Mount Plate
5	57-2000-1	1	Push Plate Assembly
6	955-3772-SPO	1	Brake Hydraulic Cylinder
7	75-2230-1-6	4	Brake Actuator Mount Angle

## XT SERIES OPTIONAL DRUM BRAKE ASSEMBLY

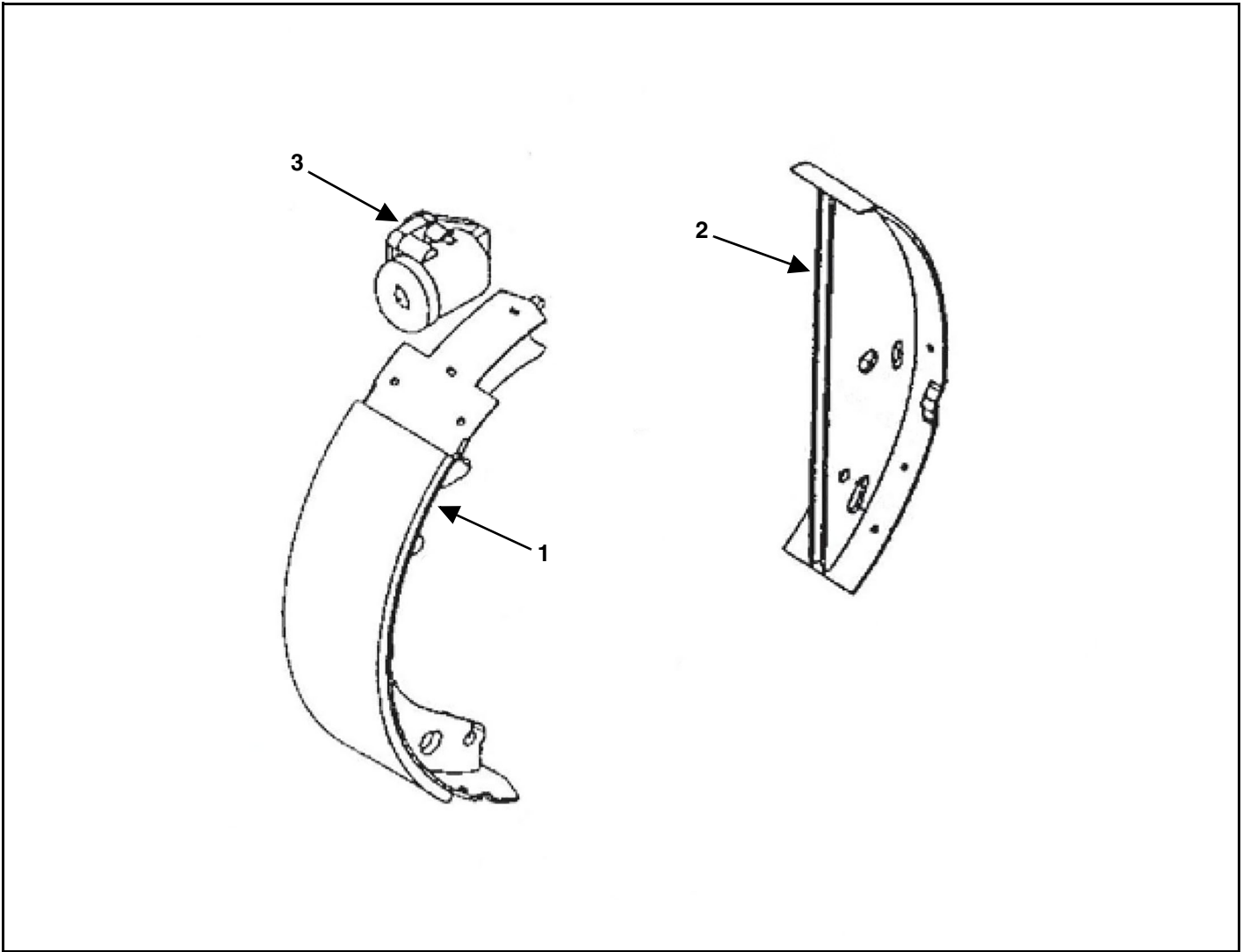

KEY	PART NUMBER	QTY	DESCRIPTION
0	57-0002	1	13" R.H. Free Backing Brake Assembly
	57-0003	1	13" L.H. Free Backing Brake Assembly
1	57-0002-5	1	Shoe Assembly
2	57-0002-3	1	Brake Shoe Assembly
3	57-0003-1	1	Wheel Cylinder Assembly Left
	57-0002-1	1	Wheel Cylinder Assembly Right (Not Shown)

## SURGE BRAKE PLUMBING

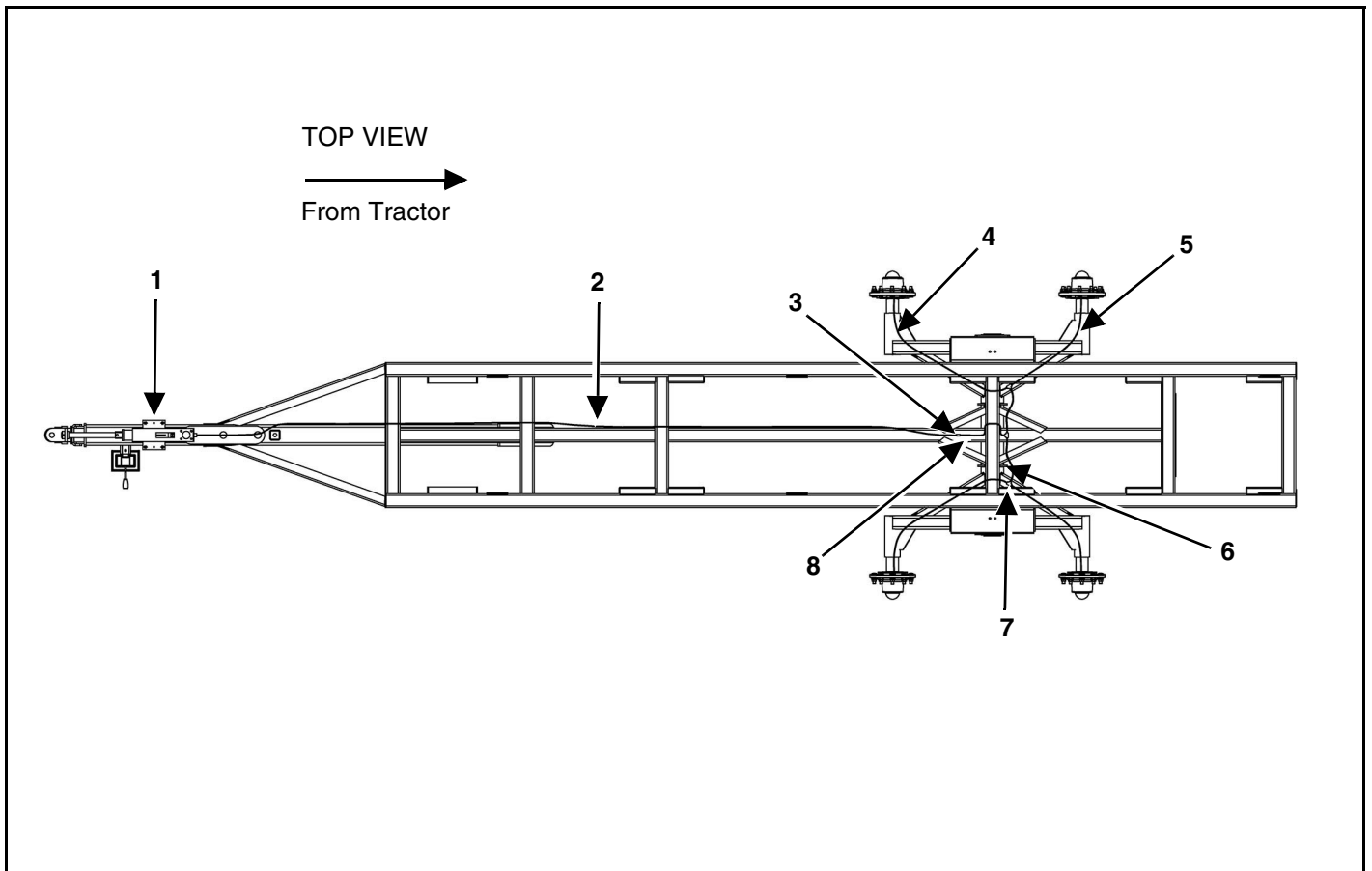

KEY	PART NUMBER	QTY	DESCRIPTION
1	See Page 52	1	XT Trailer Optional Surge Brake Actuator Assembly
2	57-0036	1	240" Brake Line Assembly
3	57-0014-2	1	Brake Line Union (XT22-264, XT22-280)
4	57-0027	2	48" Brake Line Assembly
5	57-0021	2	41" Brake Line Assembly
6	57-0010	2	18" Hydraulic Brake Hose
7	57-0013	3	Frame Tee With Clip
8	57-0069	1	37" Brake Line Assembly (XT22-264)
	57-0021	1	41" Brake Line Assembly (XT22-280)

## HAND LEVER CONTROL BRAKE PLUMBING

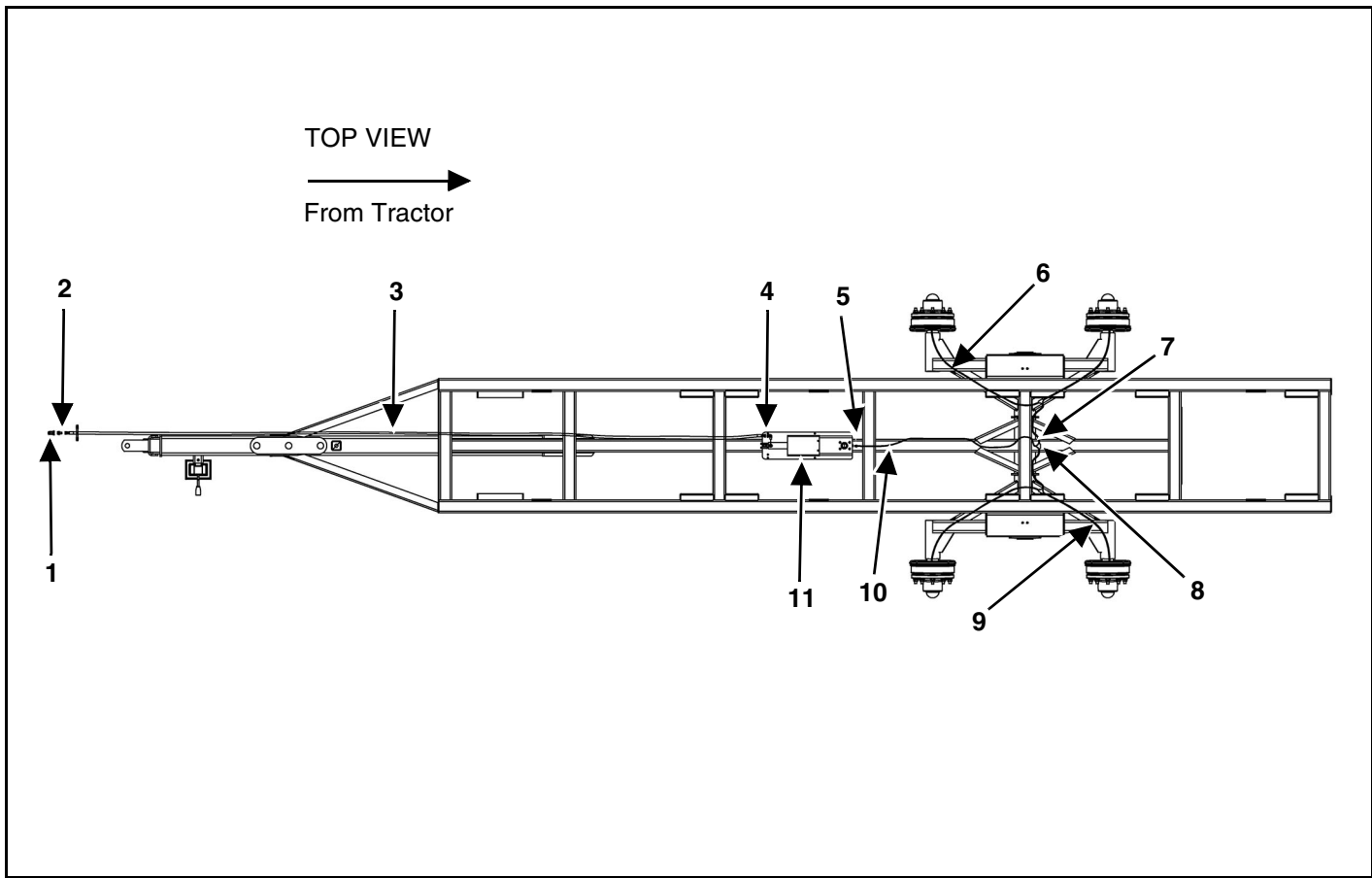

KEY	PART NUMBER	QTY	DESCRIPTION
1	155-8010-15	1	#8 ORB Male Tip
2	155-6400-6-8	1	Straight Adapter
3	155-04R17-233-1	1	Hose 1/4" x 233" (XT22-216)
	155-04R17-251-1	1	Hose 1/4" x 251" (XT22-264, XT22-280)
4	155-2501-06-04	1	Adapter Fitting 90°
5	57-0029-17	1	Inverted Flare Full Flow Fitting Orifice
6	57-0027	2	Brake Line Assembly 48"
7	57-0010	2	Hydraulic Brake Hose 18"
8	57-0013	3	Frame Tee With Clip
9	57-0015	2	Brake Line Assembly 30"
10	57-0062	1	Brake Line Assembly (XT22-216) 60"
	57-0013	1	Brake Line Assembly (XT22-264) 80"
	57-0020	1	Brake Line Assembly (XT22-280) 90"
11	See Page 58	1	XT/XTL/XTH Trailer Optional Hand/Foot Control Brake Actuator Assembly

## FOOT PEDAL CONTROL BRAKE PLUMBING

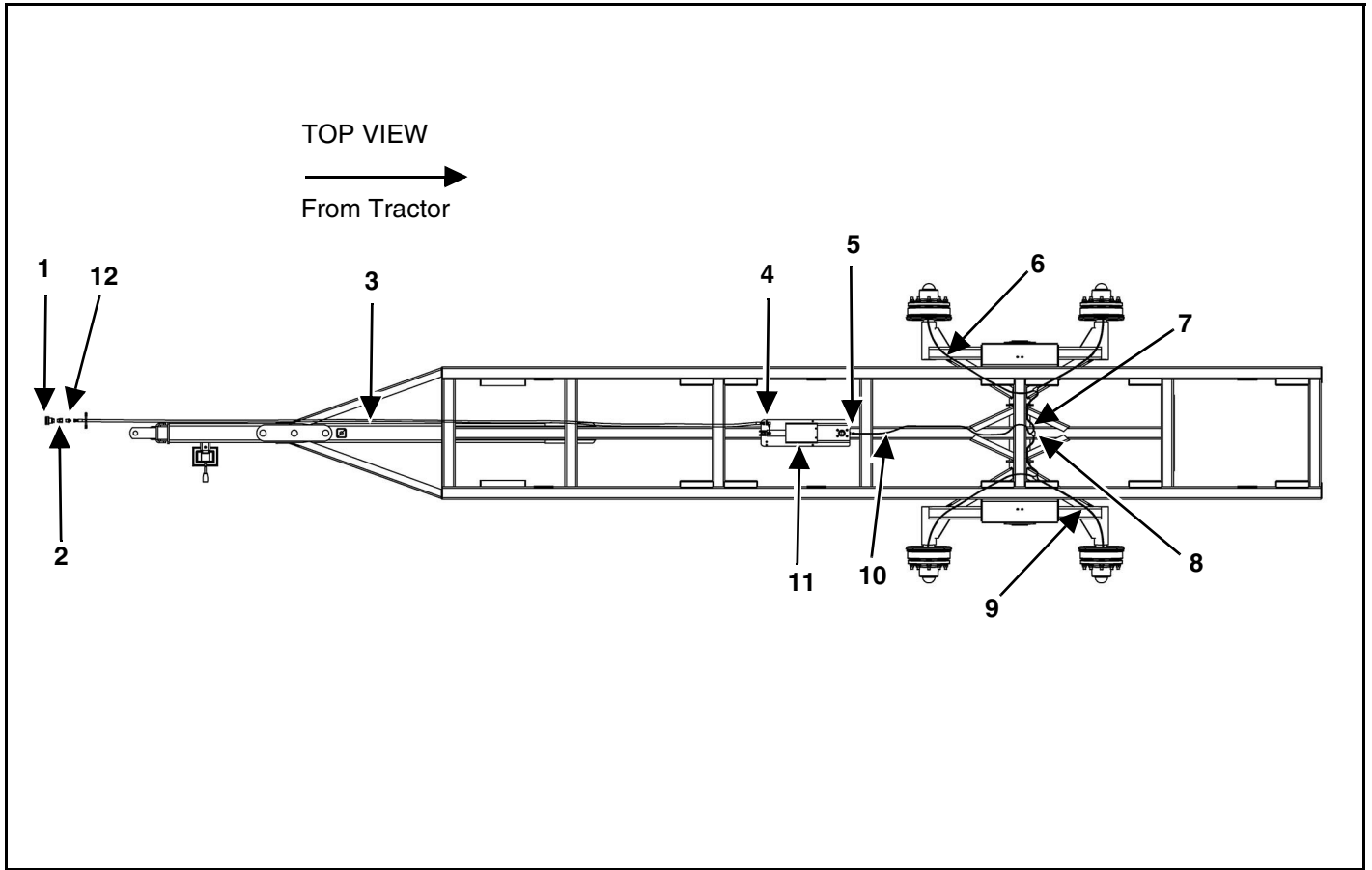

KEY	PART NUMBER	QTY	DESCRIPTION
1	55-0212	1	Female Flat Face Coupler
2	155-PB08-08	1	Straight Adapter With BSP Bonded Seal
3	155-04R17-233-1	1	Hose 1/4" x 233" (XT22-216)
	155-04R17-251-1	1	Hose 1/4" x 251" (XT22-264, XT22-280)
4	155-2501-06-04	1	Adapter Fitting 90°
5	57-0029-17	1	Inverted Flare Full Flow Fitting Orifice
6	57-0027	2	Brake Line Assembly 48"
7	57-0010	2	Hydraulic Brake Hose 18"
8	57-0013	3	Frame Tee With Clip
9	57-0015	2	Brake Line Assembly 30"
10	57-0062	1	Brake Line Assembly (XT22-216) 60"
	57-0013	1	Brake Line Assembly (XT22-264) 80"
	57-0020	1	Brake Line Assembly (XT22-280) 90"
11	See Page 58	1	XT/XTL/XTH Trailer Optional Hand/Foot Control Brake Actuator Assembly
12	155-2404-06-08	1	Straight Adapter





## 9.0 SPECIFICATIONS

### SUSPENSION TRAILER SPECIFICATIONS

MODEL	XT1600/XT16-162	XT1600L/XT16-202	XT2200/XT22-216	XT2200L/XT22-240	XT2200XL/XT22-264
Style	Tandem	Tandem Long	Tandem	Tandem Long	Tandem Long
Capacity	32,000#	32,000#	44,000#	44,000#	44,000#
Tread Width	82"	82"	80"	80"	80"
Spindle Size	3"	3"	3.5"	3.5"	3.5"
Heavy Duty Hubs	8-Bolt 8,000# at 10 MPH	8-Bolt 8,000# at 10 MPH	10-Bolt 15,000# at 10 MPH	10-Bolt 15,000# at 10 MPH	10-Bolt 15,000# at 10 MPH
Frame Design	3 x 6 x 1/4" Tubing	3 x 6 x 1/4" Tubing	4 x 8 x 1/4" Tubing	4 x 8 x 1/4" Tubing	4 x 8 x 1/4" Tubing
Weight (w/riser)	3,145# 425/65 x 22.5	3,240# 425/65 x 22.5	3,680# w/21.5 x 16.1	3,810# w/21.5 x 16.1	3,950# w/21.5 x 16.1
Overall Length	20' 8-1/2"	24'	25' 2-1/2"	27' 2-1/2"	29' 2-1/2"
Bed Length	13' 7"	16' 10-1/2"	18'	20'	22'
Overall Width	100-1/2" w/16.5L x 16.1	100-1/2" w/16.5L x 16.1	102-1/2" w/21.5 x 16.1	102-1/2" w/21.5 x 16.1	102-1/2" w/21.5 x 16.1
	98-1/4" w/425/65 x 22.5	98-1/4" w/425/65 x 22.5	98-1/2" w/425/65 x 22.5	98-1/2" w/425/65 x 22.5	98-1/2" w/425/65 x 22.5
Bed Width	42"	42"	42"	42"	42"
Stake Spacing	42"	42"	42" or 33 1-1/2" (Opt or Std)	42" or 33 1-1/2" (Opt or Std)	42" or 33 1-1/2" (Opt or Std)
Bed Height	32" w/14L x 16.1 W/O Riser	32" w/14L x 16.1 W/O Riser	44" w/21.5 x 16.1	44" w/21.5 x 16.1	44" w/21.5 x 16.1
	38-1/2" w/425/65 x 22.5 W/Riser	38-1/2" w/425/65 x 22.5 W/Riser	43-1/4" w/425/65 x 22.5	43-1/4" w/425/65 x 22.5	43-1/4" w/425/65 x 22.5
Adj. Clevis Hitch	Standard	Standard	Standard	Standard	Standard

### OPTIONS

MODEL	XT1600/XT16-162	XT1600L/XT16-202	XT2200/XT22-216	XT2200L/XT22-240	XT2200XL/XT22-264
Surge Brakes	NA	NA	Optional	Optional	Optional
Swivel Clevis Hitch	NA	NA	Optional	Optional	Optional
4" Riser Package	Required for 19L x 16.1 or 425/65 x 22.5	Required for 19L x 16.1 or 425/65 x 22.5	NA	NA	NA
Various Tires Sizes	See Dealer	See Dealer	See Dealer	See Dealer	See Dealer

**TRAILER AND BOX MOUNTING SPECIFICATION SHEET**

<b>BOXES / TRAILERS</b>	<b>XT1600/XT16-162</b>	<b>XT1600L/XT16-202</b>	<b>XT2200/XT22-216</b>	<b>XT2200L/XT22-240</b>	<b>XT2200XL/XT22-264</b>
4516	OK	NA	NA	NA	NA
4518	NA	OK	NA	NA	NA
4616	OK	NA	NA	NA	NA
4618	NA	OK	NA	NA	NA
4620	NA	OK	OK	NA	NA
4622	NA	NA	OK	OK	NA
4116	OK	NA	NA	NA	NA
4118	OK	NA	NA	NA	NA
4120	NA	OK	OK	NA	NA
4122	NA	NA	OK	NA	NA
4216	OK	NA	NA	NA	NA
4218	NA	OK	NA	NA	NA
4220	NA	OK	OK	NA	NA
4222	NA	NA	OK	OK	NA
6218	NA	OK	NA	NA	NA
6220	NA	NA	OK	NA	NA
6222	NA	NA	NA	OK	NA
6224	NA	NA	NA	NA	OK
3514	OK	NA	NA	NA	NA
3516	OK	NA	NA	NA	NA
3518	NA	OK	NA	NA	NA
3516-FB	OK	NA	NA	NA	NA
3518-FB	NA	OK	NA	NA	NA
3116	OK	NA	NA	NA	NA
3118	OK	NA	NA	NA	NA
3120	NA	OK	OK	NA	NA
3216	OK	NA	NA	NA	NA
3218	NA	OK	NA	NA	NA
3220	NA	OK	OK	NA	NA
8118	NA	NA	OK	NA	NA
8120	NA	NA	OK	NA	NA
8122	NA	NA	OK	OK	NA
8124	NA	NA	NA	OK	OK
8126	NA	NA	NA	NA	NA
9122	NA	NA	OK	OK	NA
9124	NA	NA	NA	OK	OK
9126	NA	NA	NA	NA	NA
9128	NA	NA	NA	NA	NA
9130	NA	NA	NA	NA	NA

NA - Not available

**LOADED BOXES MUST NOT EXCEED CARRYING CAPACITY OF TRAILERS**

**PTO UNLOAD BOXES: 50" - 64" HITCH PIN TO IMPLEMENT PTO KNUCKLE**

**HYDRAULIC UNLOAD BOXES: 50" - 64" HITCH PIN TO FRONT OF BOX/UNIT**

**81 / 9100 BOXES ON XT2000 SERIES TRAILERS: 12" OVER HANG OF BOX ON THE FRONT OF THE TRAILER.**





**Meyer Manufacturing Corporation**

674 W. Business Cty Rd A

Dorchester, WI 54425

Phone: 1-800-325-9103

Fax: 715-654-5513

Email: [parts@meyermfg.com](mailto:parts@meyermfg.com)

Website: [www.meyermfg.com](http://www.meyermfg.com)