

**INSTALLATION INSTRUCTIONS  
FOR THE**  
**Hilkoil** Energy Saving Hot Water Kit

**IMPORTANT:** These installation instructions are meant to be used as a guide for woodstove owners and plumbers to follow. Failure to follow these instructions properly may result in a faulty installation, which could result in damage to system and/or self. Study the instructions thoroughly before beginning any work.

\* \* \* \* \*

1. Wash the heat exchanger coil out with hot soapy water and rinse. This will insure that no residues will be left inside the coil from the manufacturing process.
2. Measure the distance from center to center of the holes on the ends of the heat exchanger coil. This measurement may be 6", 8", or 9" depending on your coil kit model number.
3. Locate a space within the stove where the coil will not interfere with any of the internal parts. With a centerpunch and hammer, mark two points (measurement in step one) on the outside of the stove that will correspond with the free space inside. If your stove is cast iron, **DO NOT** attempt to centerpunch it, as it will crack. Mark the stove with a felt tipped pen if it is cast iron.
4. With the drill provided in the holesaw, drill a 1/4" hole at each of the marks. These will be the center of the larger holes that will accommodate the coil legs, so make sure that they are spaced properly and do not interfere with anything inside the stove, i.e., firebrick, baffles, etc. If the holes are not properly spaced, now is the time to re-drill them.
5. Once you are satisfied with the 1/4" hole placement, replace the drill in the holesaw and tighten it. Using the 1/4" hole as a guide for the drill/holesaw assembly, operate at a slow speed using cutting oil to keep it cool as it cuts. Be sure to run the holesaw slowly, evenly, and perpendicular to the flat surface of the stove.
6. Figure 1 shows how the heat exchanger coil is to be fastened to the inside of the stove. Following this diagram, run a locknut all the way to the end of each leg, flat side toward the firebox, making sure there are no threads exposed inside.

## INSTALLATION OF WATER COIL INSIDE THE FIREBOX

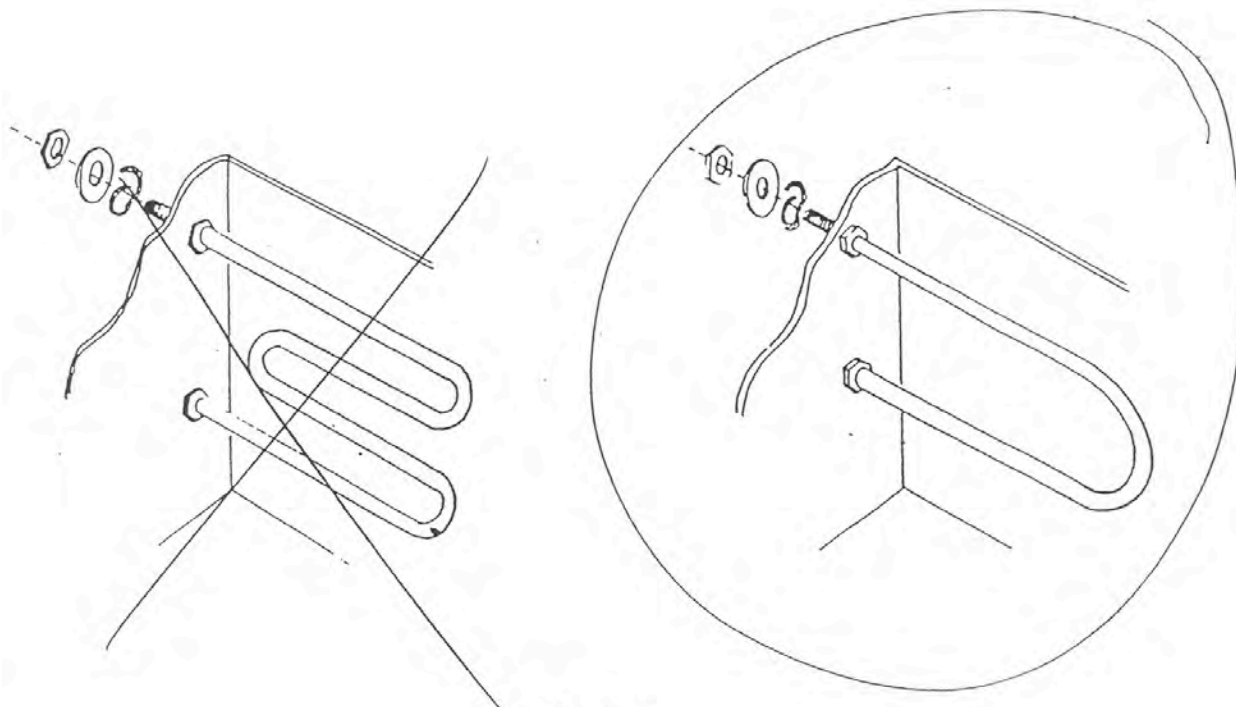

Figure 1

7. Place the coil through the holes from the inside of the firebox and run a washer and nut down each leg on the outside of the stove. Before tightening the nuts down completely, wrap a piece of hi-temp fiberglass rope gasket, provided with the kit, around each threaded leg between the washer and the outside of the firebox. Tighten the locknuts down securely to insure an air-tight installation. The heat exchanger coil may be installed vertically, as shown in figure 2, or horizontally, in which case it does not matter which leg is plumbed to or from the hot water heater, as they will both be at the same level.

The installation is now ready to be plumbed to your existing domestic hot water system. Choose one of the three methods described below that will best suit your particular needs.

### THERMO-SIPHON METHOD

This is the simplest and most economical method; however, the hot water tank must be less than ten feet from the stove. The water inlet, where the temp/pressure relief valve is located, must be higher than the top leg of the coil. The hot water tank should be elevated, if necessary, to allow for proper thermo-siphon action (the method by which hot water will circulate automatically through the system).

## THERMO-SIPHON METHOD

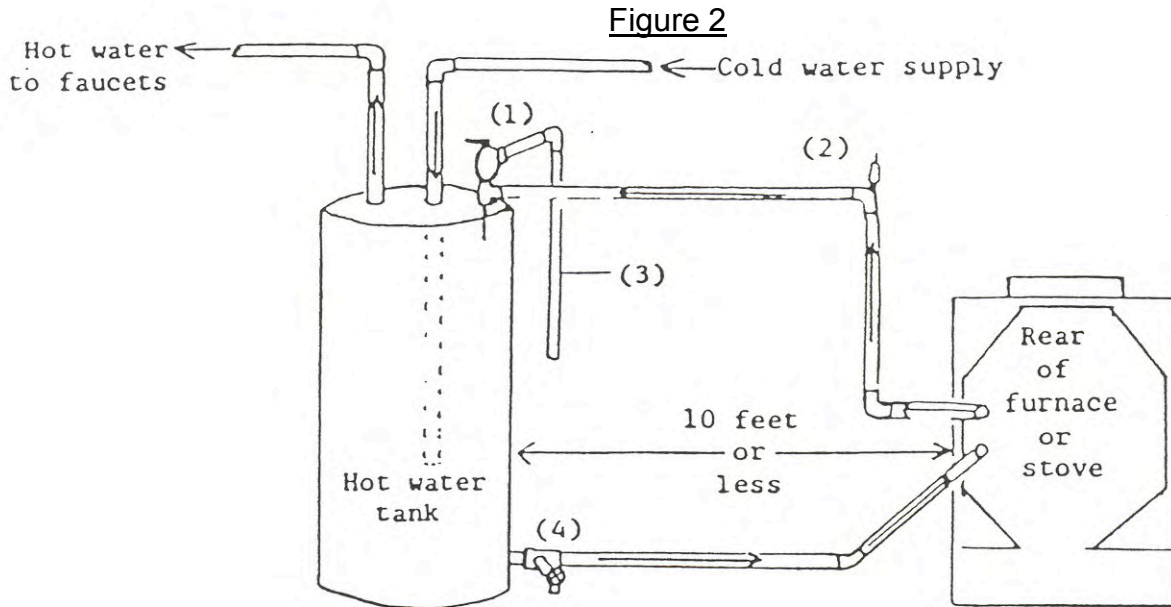

- a) Shut off the hot water heater and the cold water supply to it. Drain the tank completely.
- b) Remove the existing temp/pressure relief valve and discard. Install a short  $\frac{3}{4}$ " nipple and tee (1) along with the new temp/pressure relief valve supplied with the kit.
- c) Run  $\frac{3}{4}$ " copper tubing along with the necessary fittings between the hot water tank and the top leg of the water coil. Install a  $\frac{3}{4}$ " vent elbow and automatic "float type" air vent (2) in the high point of the line. Run  $\frac{3}{4}$ " tubing from the release exit of the temp/pressure relief valve downward (3) so that hot water may escape in the event of overheating.
- d) Remove the drain valve at the bottom of the tank. Install a short  $\frac{3}{4}$ " nipple and tee and re-install the drain valve to the tee (4). Run  $\frac{3}{4}$ " copper tubing with the necessary fittings between the drain/tee combination and the lower leg of the coil. After all of the connections have been completed, you may refill the tank. Turn on the hot water heater only after the tank has been completely refilled.

## TEMPERING TANK METHOD

This is a method used when the hot water tank is located more than ten feet away from the stove. The tempering tank is installed the same way as the hot water tank in the thermo-siphon method, but acts as an additional holding tank for the existing hot water tank. The advantages of this method are that hot water capacity is greatly increased, there is no need for a circulating pump, and the tempering tank, during the summer months, allows cold water to set and be warmed before being drawn through the hot water tank, putting less of a demand on the heater. An old hot water tank without the electrical connections is ideal for this purpose; however, any holding tank will do if it is modified according to the drawings in Figure 4.

Figure 3  
TEMPERING TANK METHOD

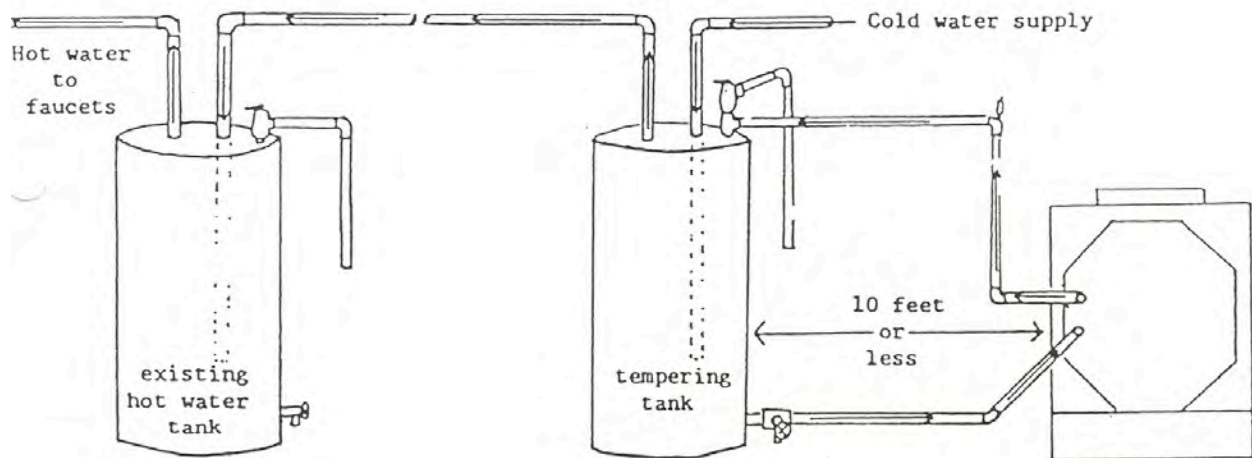

- a) Following the instructions under Figure 3, connect the tempering tank to the heat exchanger coil in the same manner as the hot water tank in the thermo-siphon method, making sure it is located less than ten feet from the stove. Note that the cold water supply is connected to the inlet on the tempering tank. Be sure that the inlet pipe extends at least halfway to the bottom.
- b) Run  $\frac{3}{4}$ " copper tubing from the tempering tank outlet to the marked cold water inlet on the existing hot water heater. We recommend replacing the existing T/P relief valve with a new one, such as the one supplied with the kit.

## CIRCULATING PUMP METHOD

This method is used when the hot water heater tank is more than ten feet away from the stove and a tempering tank is not available, or the stove is on a higher level than the hot water heater tank. In addition to a circulating pump, you will need an aquastat to thermostatically control it as the water temperature varies. A gate valve placed near the pump will allow for manual control of the water flow.

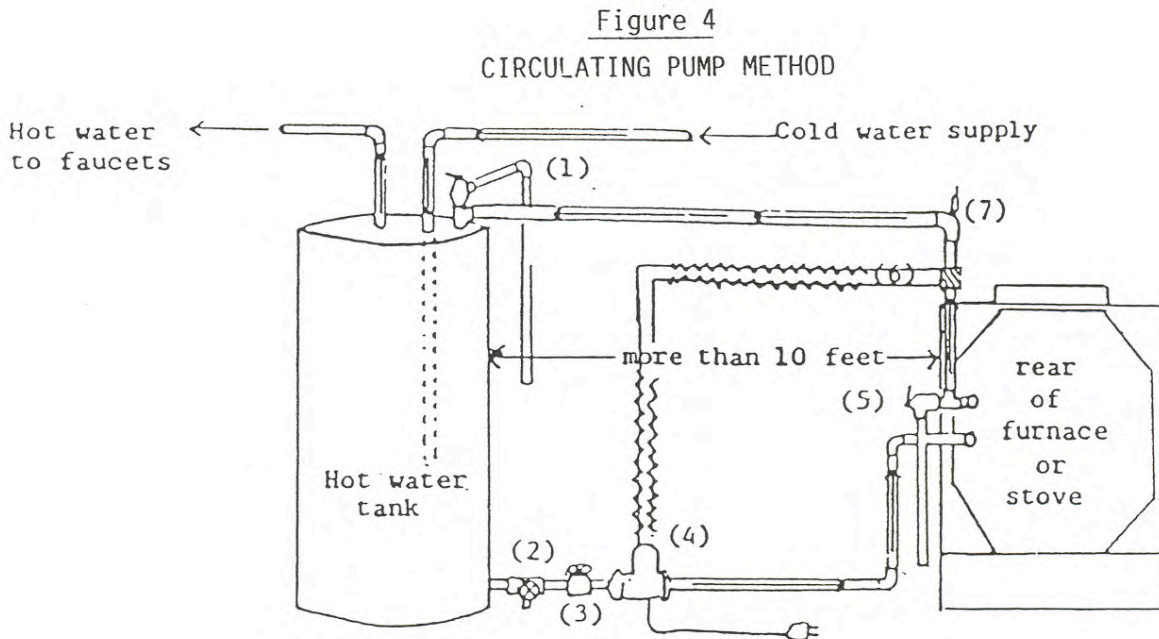

- a) Shut off hot water heat and the cold water supply to it and drain completely.
- b) Remove the existing temp/pressure relief valve on the hot water heater and replace it with a  $\frac{3}{4}$ " short nipple and tee. Install a new valve and run an escape line downward (1) as shown.
- c) Remove the drain valve at the bottom of the tank. Install a  $\frac{3}{4}$ " short nipple and tee and re-install the drain valve to the tee (2).
- d) Install a gate valve (3) leading away from the tee and a circulating pump (4) as shown. Run  $\frac{3}{4}$ " copper tubing from the circulating pump to the lower leg of the heat exchanger coil.
- e) Install a  $\frac{3}{4}$ " tee to the top leg of the coil with the new temp/pressure relief valve, supplied in the kit, coming out of the tee. (5)
- f) Run  $\frac{3}{4}$ " copper tubing from the tee at the top leg of the coil and install an aquastat (6), wiring it to the circulating pump. Complete the  $\frac{3}{4}$ " copper line by running it back to the tee at the top of the hot water tank, making sure to install a  $\frac{3}{4}$ " vent elbow and automatic air vent (7) at the high point of the line. The system is now ready to be refilled and the hot water heater turned back on.

ALWAYS be sure the sensing element of the temp/pressure relief valve is immersed in water in the upper 6" of the heater tank.

NEVER use plastic tubing between the coil installation and the hot water heater. The heat from the stove or furnace could melt the plastic.

NEVER connect a supply line to the escape outlet of any temp/pressure relief valve.

Hot water generated from the heat exchanger installation could reach temperatures of 180-190 degrees F if it is not used. It is advisable to install a hot water tempering valve, adjusted to 130 degrees F, to avoid scalding temperatures.

**WARRANTY**

THERMO-BILT, Inc. warrants the stainless steel heat exchanger coil to be free from defects in materials and workmanship for a period of ten years from the date of purchase by the original owner. If, during the warranty period, the stainless steel heat exchanger should burn out for any reason other than obvious intentional misuse, it will be replaced with a new one when returned, postpaid, with proof of purchase. We make no warranty covering consequential damages, incidental damages, or incidental expenses, including injury to persons or property, which may occur during the use of this product.

THERMO-BILT, Inc. Box 3207 Schenectady, NY 12303  
PHONE # (518) 377-4004

To register warranty, complete the form below and mail to: THERMO-BILT, INC., P. O. Box 3207, Schenectady, NY 12303

-----  
Owner's Name \_\_\_\_\_

Address \_\_\_\_\_

Date of Purchase \_\_\_\_\_

Dealer's Name \_\_\_\_\_

Address \_\_\_\_\_

Coil Model or Type \_\_\_\_\_

WOODCHUCK WATER COIL INSTALLATION

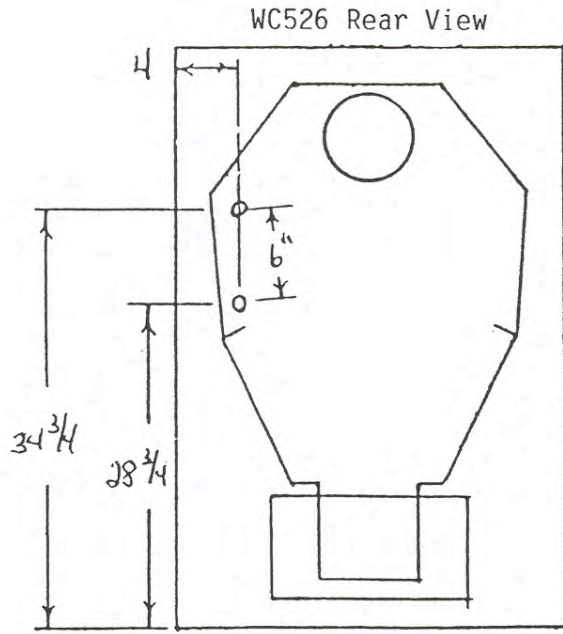
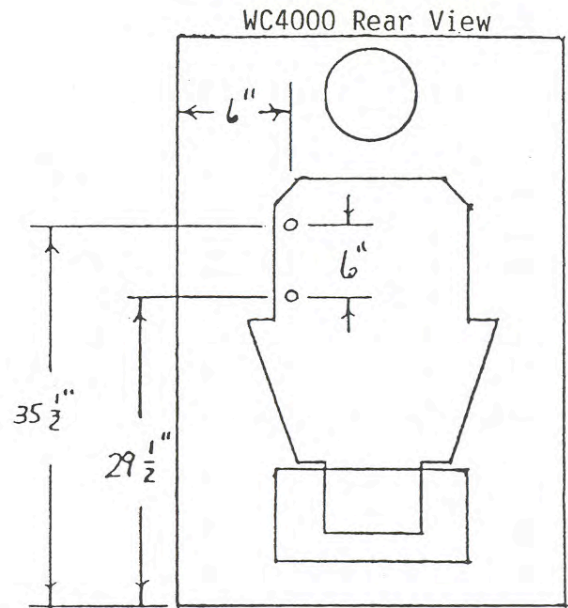
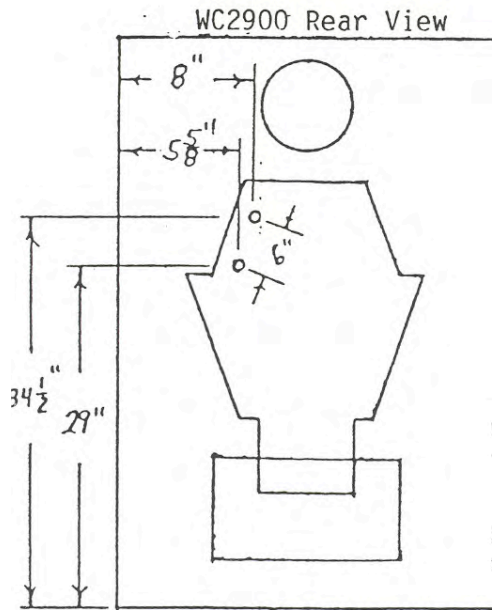

On WC526, use center punch first to mark location, then check for punch marks inside of firebox. There should be 1"-1 $\frac{1}{4}$ " clearance of angle iron reinforcements. May have to make adjustments accordingly. (Revised 10-93)