

OPERATORS AND PARTS MANUAL NO. 02-7-V-MAX

MEYER

V- MAX

TWIN EXPELLER SUPER SPREADER

MODELS: 2636
3245
3954

US PATENT NO.
5,368,236
5,501,404



DO NOT OPERATE EQUIPMENT UNTIL THIS MANUAL HAS BEEN READ AND UNDERSTOOD.

MEMBER



Over
65 years
of service
to our customers

Manufactured by

Meyer Mfg. Corp.

County Hwy. A West
P.O. Box 405

Dorchester, Wisconsin 54425
Phone 715-654-5132 • FAX 715-654-5513
1-800-325-9103

www.meyermfg.com

E-mail: sales@meyermfg.com



INTRODUCTION

Congratulations on your purchase of a new Meyer farm equipment product. Undoubtedly you have given much consideration to your purchase and we're proud that you have selected Meyer. Pride in craftsmanship, engineering and customer service have made Meyer products the finest in the farm equipment industry today.

There is no substitute for quality. That is why thousands of people like you have purchased Meyer farm equipment. They felt it was the best equipment to serve their farming needs, now and in years to come. We ask that you follow our policy of "safety first," and we strongly suggest that you read through the owner's manual before operating your Meyer farm equipment.

Meyer Manufacturing Corporation wants to thank you for not compromising quality. We are determined to offer excellence in customer service as well as provide you with the very best value for your dollar.

REMEMBER:

FARM EQUIPMENT BUYERS TRUST THE NAME MEYER!

Sincerely,

All Employees of
MEYER MANUFACTURING CORPORATION

Meyer Mfg. Corp. reserves the right to make improvements in design, or changes in specifications at any time, without incurring any obligation to owners of units previously sold.

This supersedes all previous published instructions.

IMPORTANT:

At the front of this manual is a [Product Registration and Inspection Certificate](#). Be sure your dealer has completed this certificate and promptly forwarded a

copy to Meyer Mfg. to validate the manufacturer's warranty. The product model and serial number are recorded on this certificate and below for proper identification of your Meyer Super Spreader by your dealer and the manufacturer when ordering repair parts. The serial number plate is found on the upper left front corner of the spreader or stamped in the left front frame channel.

Model No. _____

Serial No. _____

Date of Purchase _____

At the back of this manual is the repair parts section. All replacement parts are to be obtained from or ordered through your Meyer dealership. When ordering repair parts, refer to the parts section and give complete information including quantity, correct part number, detailed description and even Model No. and Serial No. of the Meyer Super Spreader which needs repair parts.

HOW TO READ YOUR SERIAL NUMBER

Your serial number is stamped on the front left hand frame channel.

Example: SV123245253

Model Type / Model Year / Model / Sequence of Build

↓ ↓ ↓ ↓
SV 12 3245 253

NOTE: All references to right hand (RH), left hand (LH), front and rear apply to the product as viewed from the rear of the spreader.

Table of Contents

INTRODUCTION	2
HOW TO READ YOUR SERIAL NUMBER	2
MANUFACTURER'S WARRANTY	4
SAFETY PRECAUTIONS	5
STUDY THE ABOVE SAFETY RULES	5
SAFETY FIRST	6
PRE-OPERATION	8
TRANSPORTING	9
TRUCK MOUNT SPREADERS	11
FREEZING WEATHER OPERATION	11
OPERATION	12
LOADING	12
UNLOADING	12
SHEAR SPROCKET INSTRUCTIONS	13
STORAGE AFTER USE	14
PTO DRIVE LINE	15
DRIVE LINE ATTACHMENT	15
LUBRICATION	16
ADJUSTMENTS	17
SPINNER MATERIAL GUIDES	17
FRONT DRIVE ROLLER CHAINS	18
LUBRICATION	20
LUBRICATION & ADJUSTMENT FOR OPTIONAL 3RD AUGER	22
LUBRICATION FOR OPTIONAL TRUCK MOUNT MECHANICAL DRIVE SYSTEM	23
INSTRUCTIONS FOR OPTIONAL AUTOMATIC CHAIN OILER	24
REPAIR PARTS	25
FRONT SHIELD & SIDE SHAFT DRIVE	26
AUGER DRIVE, PRIMARY REDUCTION	28
AUGER DRIVE, SECONDARY REDUCTION	30
RH AUGER DRIVE, FINAL REDUCTION	32
LH AUGER DRIVE, FINAL REDUCTION	34
BOX, AUGERS & SIDE SHAFT	36
UNLOADING GATE & TRIP PAN DOORS	40
SPINNERS & GEARBOX SHAFT DRIVE	44
SPINNER GEAR REDUCERS	46
19-0047 UPPER GEARBOX - TRUCK	47
#19-0038-SYN 2:1 RATIO GEARBOX	48
HUBS, AXLE & TANDEM AXLE ASSEMBLY	50
V-MAX HIGHWAY LIGHTING	52
OPTIONAL THIRD AUGER	54
OPTIONAL OIL-KIT	56
918-0212 PTO DRIVE SHAFT ASSEMBLY	58
918-0312 PTO DRIVE SHAFT ASSEMBLY	58
1000 RPM ADD-ON KIT	61
SVS-RPM-KIT	61
918-0209 PTO DRIVE SHAFT ASSEMBLY	62
918-0211 PTO DRIVE SHAFT	62
918-0309 PTO DRIVE SHAFT ASSEMBLY	66
918-0311 PTO DRIVE SHAFT ASSEMBLY	66
918-0308 PTO DRIVE SHAFT ASSEMBLY	70
918-0310 PTO DRIVE SHAFT ASSEMBLY	70
#918-0150 VERTICAL DRIVELINE, TRUCK MOUNT MECHANICAL DRIVE	72
OPTIONAL TRUCK GEARBOX DRIVE PACKAGE	73
"TROUBLE SHOOTING"	74
MEYER EQUIPMENT WHEEL TORQUE	77
TIRE INFLATION	77
"SPECIFICATIONS"	78
"MAINTENANCE RECORD"	79

NEW MEYER SUPER SPREADER MANUFACTURER'S WARRANTY

- I. The "Product Registration & Inspection Certificate" along with the original billing invoice "Owners Registration Form" must be completed in full and promptly returned to Meyer Mfg. Corp. for this warranty to become both valid and effective. All warranties on New Meyer Super Spreaders shall apply only to the original retail customer from an authorized Meyer Mfg. Corp. dealership.
- II. This warranty shall not apply to any Meyer Super Spreader which has been subjected to misuse, negligence, alteration, accident, incorrect operating procedures, or which shall have been repaired with parts other than those obtained through Meyer Mfg. Corp.
- III. Meyer Mfg. Corp. warrants New Meyer Super Spreaders to be free from defects in material and workmanship under recommended use and maintenance service, as stated in the "Operator's and Parts Manual," as follows:
 - A. Meyer Mfg. Corp. will repair or replace F.O.B. Dorchester, WI, as Meyer Mfg. Corp. elects, any part of a new Meyer Super Spreader which is defective in material or workmanship:
 1. Without charge for either parts or labor during the first (1) year from purchase date to the original retail customer.
 - B. In addition to the above basic warranty, Meyer Mfg. Corp. will repair or replace F.O. B. Dorchester, WI as Meyer Mfg. Corp. elects:

Seven (7) Years: After a period of (1) year, the spreader tank body is warranted against rust-through for an additional period of (6) years. (Pro-Rated Parts Only). Parts included, front and rear end panels, side panels, and auger trough.
- IV. COMMERCIAL USE: Coverage as in paragraph III A1 ONLY, except warranty coverage is for (90) days for parts and labor to the original commercial retail customer.
- V. Repairs eligible for labor warranty must be made by Meyer Mfg. Corp. or an authorized Meyer dealership. The original retail customer is responsible for the transportation of the super spreader to the dealership for warranty service or for any service call expenses.
- VI. Except as stated above, Meyer Mfg. Corp. shall not be liable for injuries or damages of any kind or nature, direct, consequential, or contingent, to persons or property. This warranty does not extend to loss of crop or for any other reasons.
- VII. No person is authorized to give any other warranties or to assume any other obligation on Meyer Mfg. Corp.'s behalf unless made or assumed in writing by Meyer Mfg. Corp. This warranty is the sole and exclusive warranty which is applicable in connection with the manufacture and sale of this product and Meyer Mfg. Corp.'s responsibility is limited accordingly.
- VIII. This warranty is effective on all sales of Meyer Super Spreaders made after July 1, 2008.

Tires, optional scales and tarps fall under the original manufacturer's warranty.

SAFETY PRECAUTIONS



This symbol is used to call attention to instructions concerning personal safety. Be sure to observe and follow these instructions. Take time to be careful!



WARNING: BEFORE ATTEMPTING TO OPERATE THIS SPREADER, READ AND STUDY THE FOLLOWING SAFETY INFORMATION. IN ADDITION, MAKE SURE THAT EVERY INDIVIDUAL WHO OPERATES OR WORKS WITH THE SPREADER, WHETHER FAMILY MEMBER OR EMPLOYEE, IS FAMILIAR WITH THESE SAFETY PRECAUTIONS.

Require anyone who will operate this spreader to read and completely understand this Owner's Manual. Give necessary instructions!

DO NOT operate, service, inspect or otherwise handle this spreader until all operators have read this Owner's Manual and have been properly trained in the intended usage of the spreader.

Do not allow minors (children) or inexperienced persons to operate this spreader.

If the spreader becomes clogged, shut off the tractor engine and allow all mechanisms to stop. Disconnect PTO shaft and hydraulic hoses (relieve hydraulic pressure). Then, clean or work on the spreader as required.

Always shut off power and disconnect PTO drive shaft and unhook hydraulic hoses (relieve hydraulic pressure) from tractor to prevent accidental startup or unexpected movement before working on machine.

Do not clean, adjust, or lubricate while spreader is in motion.

Make sure all hydraulic fittings are tight and that all hoses are in good condition. Hydraulic fluid escaping under pressure can have sufficient force to penetrate skin and cause serious injury. Never investigate for hydraulic leaks by using a part of the body to feel for escaping fluid.

Inspect when first delivered and regularly thereafter; that all connections and bolts are tight and secure before operating.

Know how to stop the spreader before starting it!

Do not operate until all shields, covers, and guards are in place.

Make certain everyone is clear of the spreader before applying power.

Keep hands, feet and clothing away from moving parts. Loose or floppy clothing should not be worn by the operator.

Stay well clear of the spreader's rear discharge spinners while operating.

Do not step up on any part of the spreader at any time. Do not use PTO guard as a step.

Do not step over the power take-off shaft. Stay clear of the PTO at all times.

Keep PTO shaft telescoping tube shields turning freely. Keep PTO master shield on tractor. Replace shields missing or damaged.

Never operate PTO above normal 540/1000 RPM rating. Never connect spreader PTO shaft to a 1000 RPM tractor PTO, unless the spreader is equipped with a 1000 RPM optional kit or is factory built for 1000 RPM.

Use only properly rated tires.

Do not tow at speeds in excess of 20 MPH when transporting this spreader. Never exceed a safe travel speed.

Observe all applicable traffic laws when transporting on public roadways (where legal to do so). Check local laws for all highway lighting and marking requirements.

Always install a SMV emblem on this spreader for transporting on roadways and keep the emblem clean and bright.

When towing the spreader on public roads a safety chain of sufficient strength to support, along the line of travel, the gross weight of the spreader must be used (See Maximum Load Weight Chart in the Transporting Section). The safety chain should be attached per diagram in the Transporting Section.

MEYER MFG. CORP. PROVIDES GUARDS FOR EXPOSED MOVING PARTS FOR THE OPERATOR'S PROTECTION; HOWEVER, SOME AREAS CANNOT BE GUARDED OR SHIELDED IN ORDER TO ASSURE PROPER OPERATION. THE OPERATOR'S MANUAL AND DECALS ON THE MACHINE ITSELF WARN YOU OF DANGERS AND MUST BE READ AND OBSERVED CLOSELY.

STUDY THE ABOVE SAFETY RULES
FAILURE TO HEED MAY RESULT IN SERIOUS PERSONAL INJURY OR DEATH.



SAFETY FIRST



A brief definition of signal words that are used in this manual is as follows:

! DANGER indicates an imminently hazardous situation which, if not avoided, WILL result in death or serious injury.

! WARNING indicates a potentially hazardous situation which, if not avoided, COULD result in death or serious injury, and includes hazards that are exposed when guards are removed..

! CAUTION indicates a potentially hazardous situation which, if not avoided, MAY result in minor or moderate injury. It is also used to alert against unsafe practices.

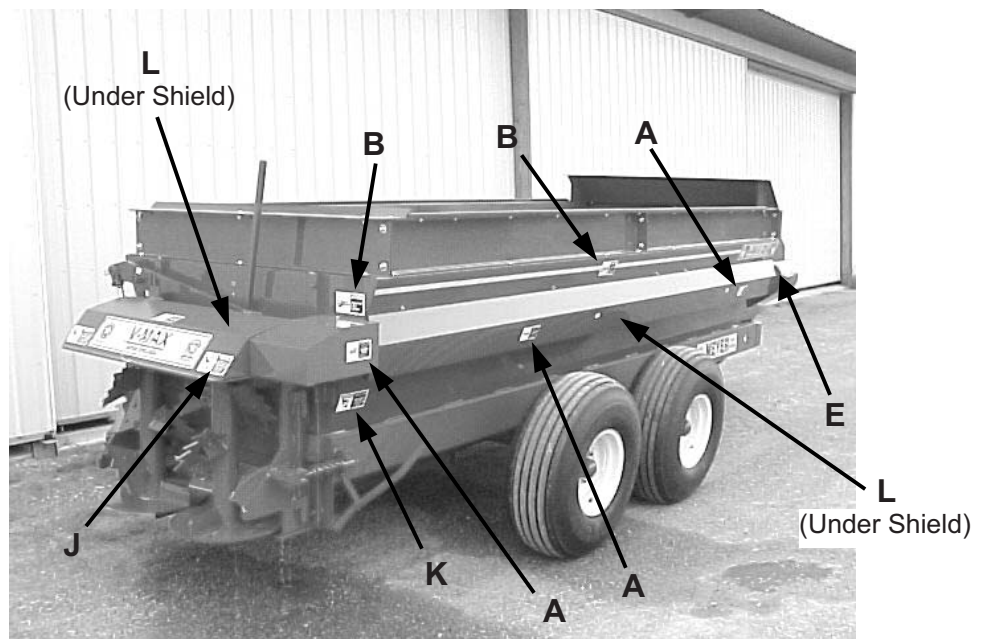
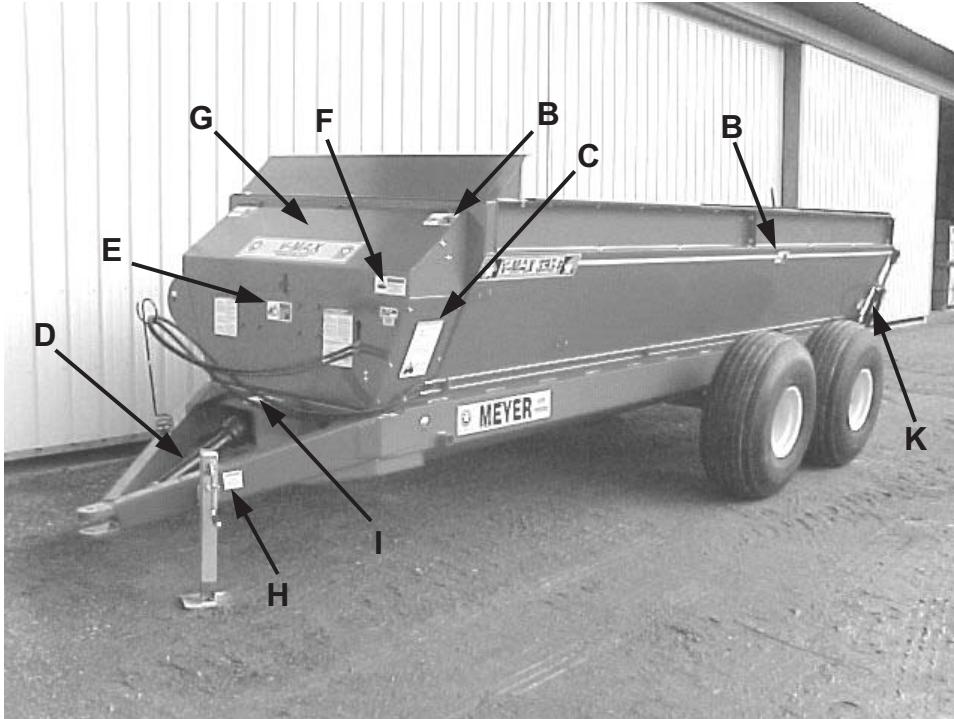

! CAUTION: READ ALL DECALS ON THE SPREADER AND IN THIS MANUAL. KEEP THESE DECALS CLEAN AND REPLACE ANY LOST OR DESTROYED DECALS. BECOME FAMILIAR WITH ALL TRACTOR AND SPREADER CONTROLS.



SAFETY FIRST



The Meyer Super Spreader is manufactured with operator safety in mind. Located on the manure spreader are various decals to aid in operation and warn of danger or caution areas. Pay close attention to all decals on the spreader.

DO NOT REMOVE ANY DECALS. IF DECALS ARE LOST, DAMAGED OR IF MANURE SPREADER IS REPAINTED, REPLACE DECALS. REMEMBER: DECALS ARE FOR YOUR PROTECTION AND INFORMATION.

CAUTION

SAFETY FIRST

(Do Not Operate This Machine Without Reading These Instructions)

Meyer Mfg. Corp. always takes the operator's safety into consideration when designing farm machinery by covering exposed moving parts for its protection; however, some areas cannot be guarded or shielded in order to assure proper operation.

This safety alert symbol  means ATTENTION! BE CAREFUL! YOUR SAFETY IS INVOLVED! It stresses an attitude of HEADS UP FOR SAFETY. Also read all other decals as they are also safety warnings.

Remember: The careful operator is the best operator. Most accidents are caused by human error. Certain precautions must be observed to prevent the possibility of injury or damage.

Read the **HEADS UP** Rules before you operate our equipment.

DO NOT allow persons other than the authorized adult operator near the machine.

DO NOT dress, adjust, or lubricate the machine when any part is in operation.

DO NOT pass in front of discharge area of machine when implement is in operation.

Tractor PTO **SHIELD** match implement PTO. (NEVER USE PTO ADAPTERS.)

IF THE MACHINE BECOMES CLOGGED, DISCHARGE POWER TAKE-OFF, REMOVE KEYS FROM TRACTOR, AND ALLOW ALL MECHANISMS TO STOP BEFORE CLEANING.

KEEP HANDS, FEET, CLOTHING, AND HAIR AWAY FROM ALL MOVING PARTS WHEN MACHINE IS IN OPERATION. LOOSE OR FLOPPY CLOTHING SHOULD NOT BE WORN BY THE OPERATOR.

STOP ENGINE, WAIT FOR ALL MOVEMENT TO STOP BEFORE LEAVING OPERATOR'S POSITION TO ADJUST, LUBRICATE, CLEAN, OR UNLOAD MACHINES, UNLESS OTHERWISE SPECIFICALLY RECOMMENDED IN THE OPERATOR'S MANUAL.

NEVER START THE MACHINE UNTIL ALL GUARDS AND SAFETY SHIELDS ARE SECURED IN PLACE.

KEEP OFF EQUIPMENT UNLESS SEAT OR PLATFORM FOR OPERATION AND OBSERVATION IS PROVIDED. KEEP ALL OTHERS OFF.

PTO SHIELD MUST ROTATE FREELY AND BE IN PLACE.

ALWAYS RUN PTO STRAIGHT IN LINE TO AVOID AN ACCIDENT BY BREAKAGE.

YOU MUST OBSERVE ALL APPLICABLE TRAFFIC LAWS WHEN TRANSPORTING ON PUBLIC ROADWAYS (WHERE LEGAL TO DO SO). CHECK LOCAL LAWS FOR ALL HIGHWAY LIGHTING AND MARKING REQUIREMENTS AND COMPLY WITH THESE LAWS.

MAKE CERTAIN EVERYONE IS CLEAR OF MACHINE BEFORE STARTING ENGINE OR OPERATION.

PLEASE KEEP ALL DECALS AND SLOW MOVING VEHICLE SIGN CLEAN SO THEY ARE LEGIBLE.

If any decal becomes damaged or lost, call your dealer or our plant for replacement.

Always use **GENUINE MEYER** replacement parts.

46-0001-22

Decal C - 46-0001-22

WARNING

ROTATING DRIVE LINE CAN CRUSH AND DISMEMBER

DO NOT OPERATE WITHOUT SHIELD IN PLACE

DISCONNECT & LOCKOUT POWER SOURCE BEFORE ADJUSTING OR SERVICING UNIT.

FAILURE TO HEED WILL RESULT IN DEATH OR PERSONAL INJURY

Decal A - 46-3600-9

DANGER

Moving Parts Inside Stay Clear

Decal B - 46-0001-5

DANGER

ROTATING DRIVE LINE

DEATH CAN RESULT FROM ENTTANGLEMENT

KEEP PEOPLE AND CLOTHING WILL CLEAR

DO NOT OPERATE WITHOUT:

- DRIVE LINE GUARDS
- INPUT SHAFT GUARDS
- TRACTOR MASTER SHIELD
- U-JOINTS LOCKED TO TRACTOR AND IMPLEMENT SHAFTS

Decal D - 46-0001-13

WARNING

ENTANGLEMENT HAZARD

Keep All Shields In Place While Machine Is Running

Decal E - 46-0001-4

WARNING

TO PREVENT SERIOUS INJURY OR DEATH

- AVOID unsafe operation or maintenance.
- **DO NOT** start, operate, or work on this machine without first, carefully reading and thoroughly understanding the entire contents of the operators manual. (Prepare the same of all personnel who will operate this machine.)
- If operators manual is lost, contact your nearest Meyer Dealership or write or call: MEYER MFG. CORP. P.O. Box 406 • Dorchester, WI 54425-0405 Phone 1-800-325-9103

Please give your name, address, model and serial number of your machine. A manual will be furnished.

- If you have any questions about operation or adjustments, and maintenance of this machine, contact your Meyer Dealership or Meyer Mfg., Corp. before starting or continuing the operation of this machine.

46-0001-35

Decal F - 46-0001-35

DANGER

ENTANGLEMENT HAZARD

Keep All Shields In Place While Machine Is Running

Decal G - 46-0001-26

WARNING

DO NOT use JACK except when spreader is empty, CRUSHING HAZARD STAY CLEAR OF HITCH

Decal H - 46-3600-6

WARNING

NOT A STEP! This is a PTO Guard. Very serious injury or amputation could result from contact with rotating PTO shaft.

Decal I - 46-0004-2

DANGER

BELOW

ROTATING PARTS INSIDE THIS OPENING. KEEP AWAY SERIOUS INJURY OR AMPUTATION COULD RESULT.

Decal J - 46-3600-1

DANGER

ROTATING PARTS

INSIDE THIS OPENING KEEP AWAY SERIOUS INJURY OR AMPUTATION COULD RESULT

Decal K - 46-3600-8

DANGER

SHIELD IS OFF Rotating Driveline Replace Shield Before Operating.

Decal L - 46-3600-2

CAUTION: READ ALL DECALS ON THE SPREADER AND IN THIS MANUAL. KEEP THESE DECALS CLEAN AND REPLACE ANY LOST OR DESTROYED DECALS. BECOME FAMILIAR WITH ALL TRACTOR AND SPREADER CONTROLS.

PRE-OPERATION



WARNING: BEFORE OPERATING, READ THIS OWNERS MANUAL COMPLETELY. PAY PARTICULAR ATTENTION TO THE “SAFETY PRECAUTIONS” AND “SAFETY FIRST” PAGES. READ ALL SAFETY MESSAGES HIGHLIGHTED BY “SAFETY ALERT SYMBOLS” THROUGHOUT THE MANUAL.

This spreader is to be operated with 540 RPM PTO only, unless the spreader is 1000 RPM equipped. The hitch of the spreader is designed for a standard tractor drawbar. Adjust the drawbar at 15 to 22 inches above the ground. Extend or shorten the drawbar so horizontal distance from end of tractor PTO shaft to center of the hitch pin hole is 14, 16 or 20 inches, dependent on RPM. Secure the drawbar so that the hitch pin hole is located directly below the PTO drive line. See figure 1 for location of standard measurements.

An improperly located hitch point may cause damage to the universal joints of the PTO drive shaft. Conforming to the standard drawbar & PTO relationship will ensure that the PTO drive shaft will not become over-extended.

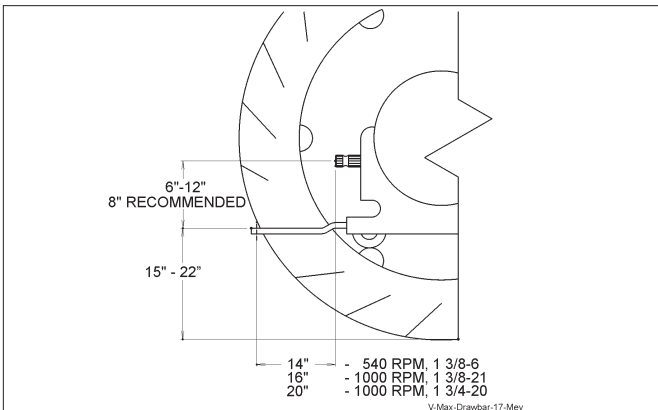

FIGURE 1. DRAWBAR & PTO RELATIONSHIP

WITH INITIAL HOOK-UP TO YOUR NEW MEYER SPREADER TEST PTO TRAVEL BY TURNING EQUIPMENT IN BOTH DIRECTIONS OBSERVING THE MINIMUM AND MAXIMUM TRAVEL DIMENSIONS AS SHOWN PER DRAWING ON FIGURE 8, PAGE 15.



DANGER: DO NOT OPERATE WITHOUT PTO GUARD ON SPREADER AND ON TRACTOR. MAINTAIN PTO DRIVE SHAFT GUARD TUBES IN OPERATING CONDITION. REPLACE THEM IF DAMAGED AND NOT TURNING FREELY. FAILURE TO HEED MAY RESULT IN SERIOUS PERSONAL INJURY OR DEATH.



WARNING: INSPECT REGULARLY THAT ALL CONNECTIONS AND BOLTS ARE TIGHT AND SECURE BEFORE OPERATING. FAILURE TO HEED MAY RESULT IN SERIOUS PERSONAL INJURY OR DEATH.

Check for proper assembly and adjustment and make sure that all bolts are tightened. Securely retighten after a few hours of operation, as bolts can loosen up on new machinery. Check wheel lug nuts upon delivery and periodically thereafter. Lug nuts should be tightened and the tires inflated to the recommended pressure. Refer to the wheel torque and tire inflation chart on page 77

Inspect all adjustments on the spreader to be sure they are proper and to provide maximum performance. Lubricate the spreader completely if it is required and check the level of liquid gear grease in all three gearboxes.



WARNING: DO NOT OPERATE WITHOUT ALL SHIELDS, GUARDS AND COVERS INSTALLED. FAILURE TO HEED MAY RESULT IN SERIOUS PERSONAL INJURY OR DEATH.

Fasten the spreader hitch to the tractor drawbar with a hitch pin that cannot bounce out. Use 1" diameter hitch pin to pull spreader.

Remove the weight from the jack (jack is not to be used when spreader is loaded). Remove jack from square mount tube and move to the transport storage tube on the left front side of the frame channel. Store in a horizontal position.

Before operation and after hitching the tractor to the spreader, connect the PTO drive shaft to the tractor. Slide spring loaded locking collar on PTO yoke rearward, and slide yoke onto the tractor PTO shaft. Release spring loaded collar. Be sure pins fall into groove of tractor PTO shaft and collar snaps forward into locking position.



CAUTION: DO NOT USE A STEEL HAMMER TO AID IN JOINING PTO PARTS.

Route hydraulic hoses through the hose support rod which is mounted to the hitch frame, figure 2. Connect the hydraulic hoses for the flow control rear gate to the tractor's double acting valve hydraulic system. Move the tractor hydraulic controls to observe proper flow gate operation. If the controls operate the gate in opposite directions to what you expect, reverse the hydraulic hose connections at the tractor.

⚠ WARNING: HYDRAULIC FLUID ESCAPING UNDER PRESSURE CAN HAVE SUFFICIENT FORCE TO PENETRATE SKIN. KEEP ALL HOSES AND CONNECTIONS IN GOOD SERVICEABLE CONDITION. FAILURE TO HEED MAY RESULT IN SERIOUS PERSONAL INJURY OR DEATH.

Before loading spreader, slowly engage the tractor PTO and operate machine at idle speed for several minutes to insure the spreader is lubricated and operating properly.
Manually latch/close the trip pan doors, figure 4.

Check that the flow control rear gate is completely closed. It is unlawful to allow slurry to splash or leak onto public roads.

TRANSPORTING

TRACTOR TOWING SIZE REQUIREMENTS

Use the following chart for calculating the minimum tractor weight.

MODEL	SPREADER EMPTY WEIGHT + LOAD = GW	MINIMUM TRACTOR WEIGHT UP TO 20 MPH
SV2636	6,100 + ____ = ____	2/3 of spreader gross weight
SV3245	7,640 + ____ = ____	2/3 of spreader gross weight
SV3954	8,650 + ____ = ____	2/3 of spreader gross weight
SI8720	11,445 + ____ = ____	2/3 of spreader gross weight
SI8865	18,140 + ____ = ____	2/3 of spreader gross weight

MATERIAL ESTIMATED WEIGHT PER CUBIC FOOT

MAXIMUM SPREADER LOAD WEIGHTS					
Model	2636	3245T	3954T	8720T	8865T
Maximum Gross Weight (Pounds)	12,000	24,000	32,000	46,445	56,140
Total Net Weight (Pounds)	6,100	7,640	8,650	11,445	18,140
Cubic Foot Capacity**	181	227	272	468	562
Capacity in Gallons	1,355	1,694	2,033	3,500	4,200
**Struck capacity, heaped loads have significantly higher capacities					

MATERIAL	LBS / CU. FT.
LIME SLUDGE	110-115 LBS.
DRY FEEDLOT MANURE	63-65 LBS.
CHICKEN LITTER	63-65 LBS.
CAKE SLUDGE	62-65 LBS.
SEMI-SOLID MANURE	58-60 LBS.
PEN PACKED MANURE	30-35 LBS.

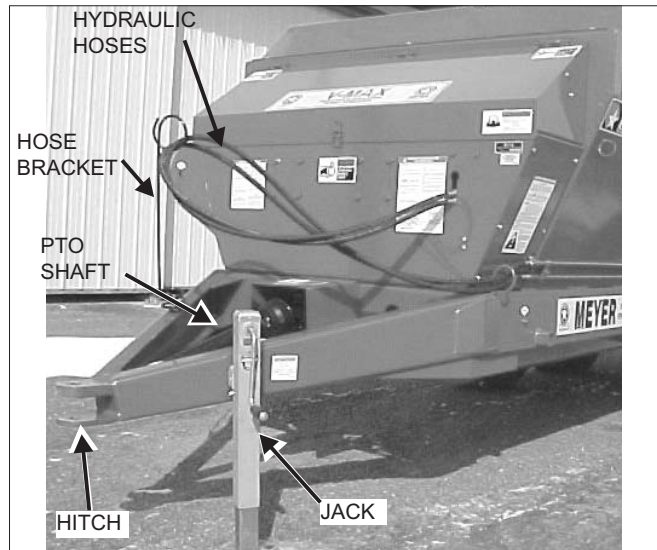

FIGURE 2. SPREADER HOOKUP

LIQUID MANURE	63-65 LBS.
---------------	------------

SOURCE: ASAE

NOTE: HEAPED LOADS HAVE SIGNIFICANTLY HIGHER CAPACITIES

⚠ WARNING: DO NOT TOW AT SPEEDS GREATER THAN 20 MPH. FAILURE TO HEED MAY RESULT IN SERIOUS PERSONAL INJURY OR DEATH.

Operating speed is dictated by the terrain over which you are traveling. Always use caution. Avoid traveling on slopes or hills that are unsafe.

⚠ WARNING: OBSERVE ALL APPLICABLE TRAFFIC LAWS WHEN TRANSPORTING ON PUBLIC ROADWAYS. CHECK LOCAL LAWS FOR ALL HIGHWAY LIGHTING AND MARKING REQUIREMENTS.

⚠ WARNING: INSTALL A SMV EMBLEM ON REAR OF SPREADER FOR TRANSPORTING ON ROADWAYS AND KEEP THIS EMBLEM CLEAN AND BRIGHT. FAILURE TO HEED MAY RESULT IN SERIOUS PERSONAL INJURY OR DEATH.

If you will travel on public roads and it is legal to do so, you must know all rules governing such operation. This will include lighting and brake requirements in addition to traffic rules. You may also be required to install a safety chain device on the spreader.

Check for traffic constantly. Be sure you can see that no one is attempting to pass you and that all traffic is sufficiently clear from you before making any turns.

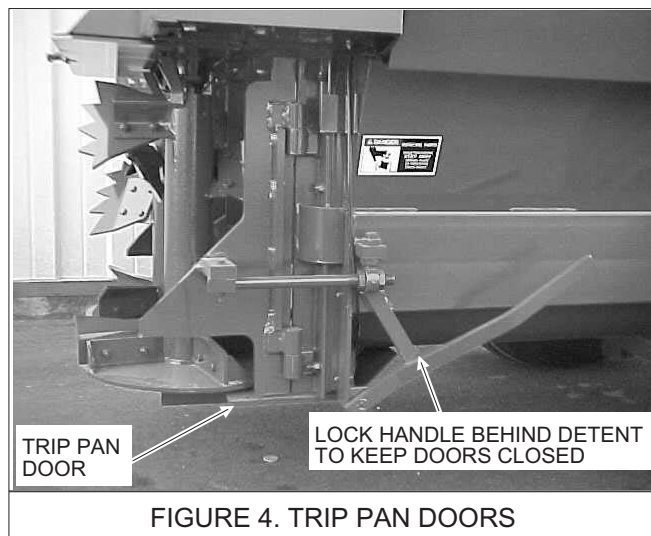
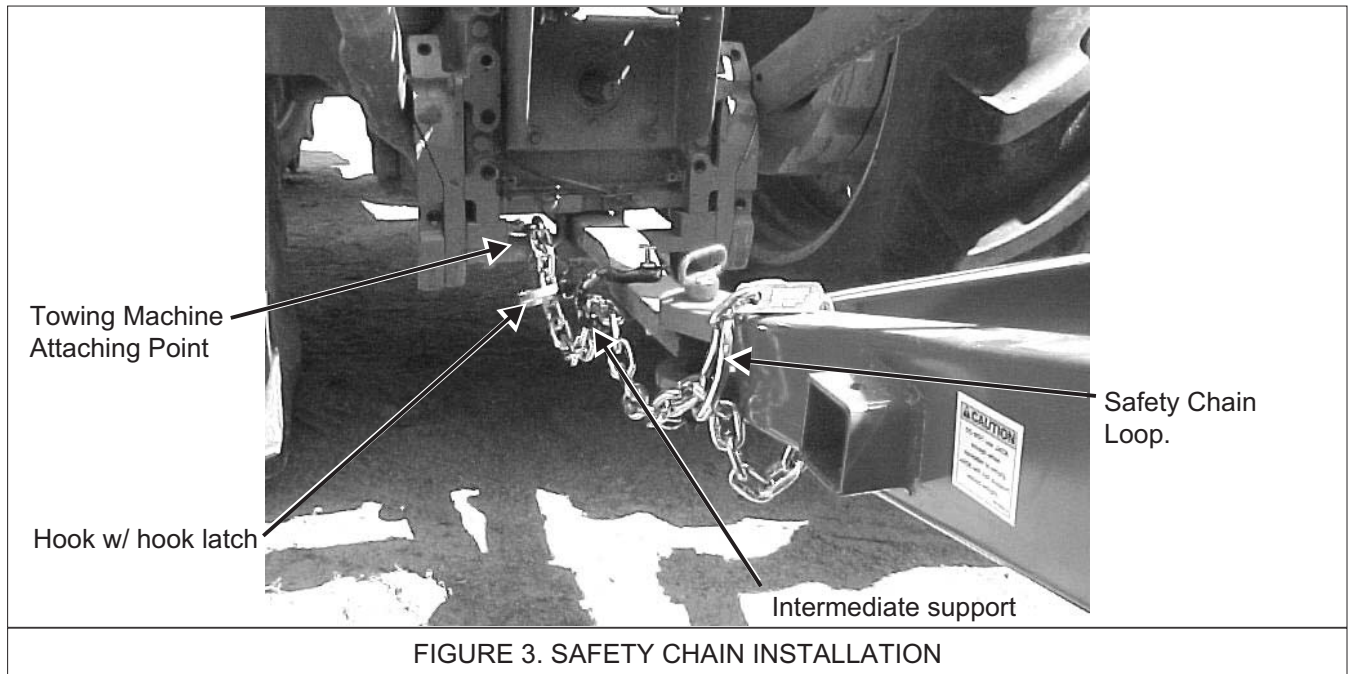

USE OF SAFETY CHAIN

 **CAUTION: A SAFETY CHAIN MUST BE INSTALLED TO RETAIN THE CONNECTION BETWEEN TRACTOR (OR OTHER TOWING VEHICLE) AND SPREADER WHENEVER TRAVELING ON PUBLIC ROADS IN CASE THE HITCH CONNECTION WOULD SEPARATE. A SUGGESTED ATTACHMENT IS ILLUSTRATED ON FIGURE 3.**

The chain must be strong enough to hold the weight of the loaded spreader (See table on page 9). If using a grab hook at the end(s) of the chain to secure the chain to itself, a hook latch must be installed.

The length of the safety chain is not to be any longer than necessary to turn without interference. If any chain links or attachment hardware are broken or stretched, repair before using. Store chain so it does not corrode or become damaged. Do not use this chain for other implements because the strength and length of the chain may not be adequate. Identify this chain for use on this particular spreader. Do not use the intermediate support as the attaching point.

TRUCK MOUNT SPREADERS

Depending on the make and model of the truck it may be necessary to install a light converter (MEYER PART #56-0028). Converter will allow signal lights and brake lights to operate according to DOT lighting standard. Call factory for more information.

FREEZING WEATHER OPERATION

Allow spreader to completely empty last of manure contents and disengage tractor PTO. Shut off tractor, remove the ignition key and allow all movement to stop before attempting to clean the spreader.

 **WARNING: DO NOT CLEAN, ADJUST OR LUBRICATE WHILE SPREADER IS IN MOTION. FAILURE TO HEED MAY RESULT IN SERIOUS PERSONAL INJURY OR DEATH.**

Manually open the trip pan doors at rear of spreader, figure 4, and scrape clean any remaining manure from inside the rear of spreader. Clean all manure from rear trip pan doors, ends of augers, flow control rear gate and spinners. Manually close the trip pan doors.

 **WARNING: MAKE CERTAIN EVERYONE IS CLEAR OF THE SPREADER BEFORE APPLYING POWER. FAILURE TO HEED MAY RESULT IN SERIOUS PERSONAL INJURY OR DEATH.**

Slowly engage the PTO. Operate the spreader several minutes to clean manure scrapings and to allow any remaining manure and the spreader to freeze dry. Hydraulically run the flow control rear gate up and down to clean gate slide guides. Park spreader with flow control rear gate approximately halfway open.

Before loading in freezing weather, manually open and close the trip pan doors at rear of spreader, make sure augers and spinners are free to rotate, and the flow control rear gate moves freely up and down.

 **DANGER: KEEP AWAY AND KEEP OTHERS CLEAR OF ROTATING SPINNERS AT REAR OF SPREADER. SERIOUS INJURY OR AMPUTATION COULD RESULT. FAILURE TO HEED MAY RESULT IN SERIOUS PERSONAL INJURY OR DEATH.**

OPERATION

LOADING

⚠ CAUTION: TO PREVENT DAMAGE TO AUGERS, SPINNERS, AND DRIVE LINES, FOREIGN OBJECTS (STONES, CONCRETE, TIMBER, METAL OR LARGE FROZEN CHUNKS OF MANURE) SHOULD NEVER BE LOADED INTO THE SPREADER.

⚠ DANGER: NEVER ENTER THE SPREADER BOX FOR ANY REASON WITHOUT FIRST DISCONNECTING PTO SHAFT FROM TRACTOR. DO NOT ALLOW OTHERS IN THE BOX. ROTATING AUGERS CAN CRUSH AND DISMEMBER. FAILURE TO HEED MAY RESULT IN SERIOUS PERSONAL INJURY OR DEATH.

⚠ CAUTION: DO NOT USE JACK EXCEPT WHEN SPREADER IS EMPTY. JACK WILL NOT SUPPORT ADDED WEIGHT. UNBALANCED WEIGHT MAY RESULT IN UNEXPECTED “TIP UP” OF SPREADER.

Before loading, especially in freezing weather, make sure the augers and spinners are free to rotate and the flow control rear gate moves freely up and down.

Manually latch close the trip pan doors at rear of spreader.

Check and be sure that the flow control rear gate is completely closed before loading.

When the spreader is parked for loading, shift the tractor to neutral or park and set the brakes. The moisture content of the manure will determine how full the spreader can be loaded so that no manure spills out.

You will probably be able to load solid manure at least level with the top of the box while semi-liquid and liquid manure will have to be less than full in the spreader box. It is unlawful to allow manure to splash or leak onto public roads.

A liquid manure kit is available for installation around the top of the box on your spreader which will aid in the containment of liquids.

UNLOADING

⚠ WARNING: MAKE CERTAIN EVERYONE IS CLEAR OF SPREADER BEFORE APPLYING POWER. FAILURE TO HEED MAY RESULT IN SERIOUS PERSONAL INJURY OR DEATH.

⚠ DANGER: KEEP AWAY AND KEEP OTHERS CLEAR OF ROTATING SPINNERS AT REAR OF SPREADER. SERIOUS INJURY OR AMPUTATION COULD RESULT. FAILURE TO HEED MAY RESULT IN SERIOUS PERSONAL INJURY OR DEATH.

When you are ready to begin spreading application on the field, open the hydraulic flow control rear gate and slowly engage the tractor PTO clutch. This can be done while traveling forward to avoid a heavier application of liquid manure at the edge of the field than desired.

For liquid and semi-liquid manure, the application rate can be controlled by the amount the flow control rear gate is opened. The height of the gate indicator bar above the rear edge of the box will provide a ready reference for the amount of opening. See figure 5. For solid manure (dry, pen-packed or manure containing long straw or hay) the flow control rear gate MUST be completely open since this material is not free flowing.



FIGURE 5. FLOW CONTROL REAR GATE

VERY IMPORTANT: THIS MACHINE IS NOT INTENDED TO BE A BALE GRINDER, HAY CHOPPER OR BEDDING MACHINE. LONG HAY OR STRAW MUST CONTAIN MANURE IN ORDER TO BE SPREAD. FAILURE TO COMPLY MAY DAMAGE THE DRIVETRAIN AND VOID THE WARRANTY.

The rear spinners have been designed and tested to provide the best spread pattern for most liquids and semi solid manure. However, the pattern will vary for each specific condition. The factors that contribute most to differing patterns will be moisture content and the amount and length of bedding material. For most typical conditions, the spread pattern should be uniform and about 15 ft. wide. When this is the case, plan your spreading patterns so you do not have to travel over previously spread manure which will be slippery, resulting in poor traction. Traction on wet grass is also poor. When the resulting pattern may require that you overlap during spreading, use precautions on slopes and hills where you could experience a loss of traction by traveling over ground with previously spread manure.

NOTE: Further control of the application rate is possible by the relationship of tractor engine speed to ground speed (transmission gear selection). For optimum, trouble-free performance it is necessary to operate at or near engine PTO speed.

When the spreader is empty, idle the tractor and stop the PTO. Close the flow control rear gate.

! WARNING: NEVER OPERATE PTO ABOVE ITS NORMAL 540/1000 RPM RATING. NEVER CONNECT SPREADER PTO SHAFT TO A 1000 RPM TRACTOR PTO, UNLESS THE SPREADER IS EQUIPPED WITH A 1000 RPM OPTIONAL KIT OR IS FACTORY BUILT FOR 1000 RPM. TRACTOR PTO MUST MATCH IMPL-

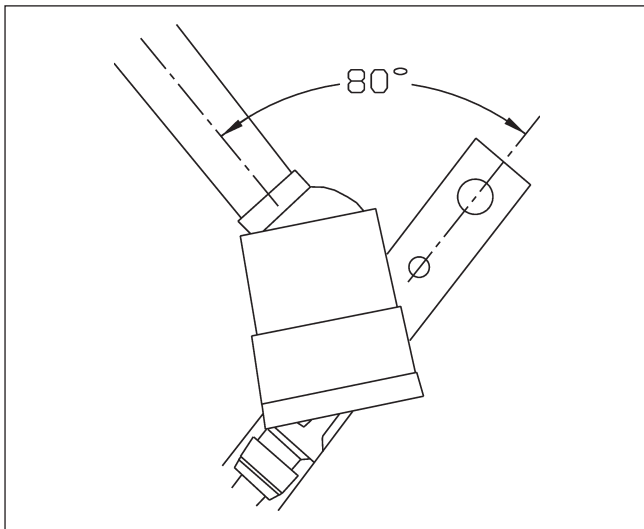

MENT PTO. FAILURE TO HEED MAY RESULT IN SPREADER DAMAGE OR SERIOUS PERSONAL INJURY.

NOTE: Failure to idle the tractor before disengaging the PTO will cause roller chain over-running and damage to the chain tighteners.

NOTE: Maximum life of the PTO shaft universal joints will result if you stop the PTO while making turns at the end of the field.

! CAUTION: DO NOT EXCEED THE MAXIMUM 80° TURNING ANGLE ON THE CONSTANT VELOCITY PTO DRIVE LINE. EXCEEDING THE TURNING ANGLE WILL DAMAGE THE CONSTANT VELOCITY "CENTER HOUSING" AND WILL EXERT EXCESSIVE PRESSURES ON THE PTO INPUT CENTER SHAFT AND RELATED BEARINGS.

SHEAR SPROCKET INSTRUCTIONS

The Meyer Spreader you have received has been equipped with a shear sprocket design on the main auger drive sprockets. The augers are being driven by two Allen head grade 8 shear bolts on each drive sprocket. The design is such that if the bolts are sheared another set of holes to install new shear bolts will always be accessible without turning over the machine.

! DANGER: AT NO TIME SHOULD INSTALLATION BE DONE WITH ANYONE ON THE TRACTOR. SHUT THE TRACTOR OFF, REMOVE THE KEY AND DISCONNECT THE DRIVE LINE BEFORE DOING ANY SERVICE ON THIS MACHINE. SERIOUS INJURY OR DEATH MAY OCCUR IF SAFETY IS NOT FOLLOWED.

Prior to Serial Number SV112636402, and SV123954243 & Later, the shear plate sprocket is set up with the standard drive bolts being 1/2"-20 (see Figure 6). If the 1/2"-20 bolts do shear, replace with the same 1/2"-20 diameter bolts after the obstruction has been removed. Install the new bolts in the proper way as to drive off of the head of the bolt, not the nut.

Shear or sprocket failure will occur if assembled incorrectly! An extra set of holes for 9/16"-18 drive bolts are located on the sprocket if additional shear strength is needed due to shear bolt failure from extra tough material that is being spread. The two different size holes available (1/2"-20 & 9/16"-18) are close in size. **Be sure to install the proper size bolt into the correct size hole. CHANGING TO THE 9/16"-18 BOLTS PROVIDES LESS PROTECTION FOR THIS EQUIPMENT.**

IMPORTANT

PROTECTION GUIDE

FOR SHEAR BOLT AUGER DRIVE SPROCKETS
USE PROPER HOLE SIZE (1/2" OR 9/16")

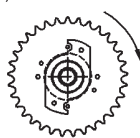
1/2"-20	- STANDARD Protection	
9/16"-18	- LESS Protection	
9/16"-18 w/ Solid Shank	- NO Protection LOCK-OUT	

VMax-ShearSprocketInstructions-Prior.cdr

FIGURE 6. PRIOR TO SERIAL NUMBER SV112636402 & SV123954243 & LATER

Serial Number SV112636402 thru SV123954242, the shear plate sprocket is set up with the standard drive bolts being 1/2"-13 (see Figure 7). If the 1/2"-13 bolts do shear, replace with the same 1/2"-13" course thread bolts after the obstruction has been removed. Install the new bolts in the proper way as to drive off of the **head** of the bolt, not the nut. **Shear or sprocket failure will occur if assembled incorrectly!** 1/2"-20 fine thread bolts are available if additional shear strength is needed due to shear bolt failure from extra tough material that is being spread. **CHANGING TO THE 1/2"-20 BOLTS PROVIDES LESS PROTECTION FOR THIS EQUIPMENT.**

IMPORTANT

PROTECTION GUIDE

FOR SHEAR BOLT AUGER DRIVE SPROCKETS
USE OUTER MOST HOLES (6 - 1/2" HOLES)

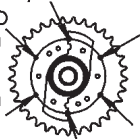
1/2"-13 Coarse Thread	- STANDARD Protection	
1/2"-20 Fine Thread	- LESS Protection	
1/2"-13 with Solid Shank	- NO Protection LOCK-OUT	

VMax-ShearSprocketInstructions-Later.cdr

FIGURE 7. SERIAL NUMBER SV112636402 THRU SV123954242

Recommended procedure to follow if shear does occur. If only one auger shears unload the opposite side of spreader and remove obstruction from sheared side of machine. After obstruction has been removed install new shear bolts in sheared auger and unload the remainder of the load. If both sides do shear install only one set of auger shear bolts and unload one side at a time. After first side is unloaded install bolts in opposite side and unload the remainder of the spreader. If a second shear has happened without obstruction in the auger, install the next larger size shear bolt. As the shear bolt size is increased the protection on the machine is going to decrease. The potential for equipment damage is greater.

Order replacement bolts and nuts from the chart below.

Prior to Serial Number SV112636402 and SV123954243 and Later

Part #	Description
831-5020-1.75	1/2-20x1-3/4" Allen Head Cap Bolt
884-5020	1/2-20 Top Locknut Grade 8
831-5618-1.75	9/16-18x1-3/4" Allen Head Cap Bolt
884-5618	9/16-18 Top Locknut Grade 8

910-0101	120B33 Shear Sprocket Assembly Complete
----------	---

Serial Number SV112636402 thru SV123954242

Part #	Description
831-5013-1.75	1/2"-13x1-3/4" Allen Head Cap Bolt
884-5013	1/2"-13 Top Locknut Grade 8
831-5020-1.75	1/2"-20x1-3/4" Allen Head Cap Bolt
884-5020	1/2"-20 Top Locknut Grade 8

910-0105	120B33 Shear Sprocket Assembly Complete (14 hole)
----------	---

STORAGE AFTER USE

WARNING: DISCONNECT PTO DRIVE SHAFT AND HYDRAULIC HOSES BEFORE CLEANING, ADJUSTING, OR SERVICING THIS MACHINE. FAILURE TO HEED MAY RESULT IN SERIOUS PERSONAL INJURY OR DEATH.

Before storing this spreader for an extended period of time perform the following:

Allow the spreader to completely clean out the last load. Thoroughly hose off all manure from the outside of the spreader and the inside of the box, particularly getting the flow control rear gate mechanism clean. The wash water can be drained into your manure storage pit, or if the gate is left closed, the water can be spread on the field. After cleaning, completely lubricate the entire spreader to exclude moisture from bearings and to prevent condensation from forming during storage. See "Lubrication" pages 20 and 21.

Apply oil to roller chain drives. It is also a good time to inspect all adjustments and check for parts that need repair or replacement. Performing these tasks now will guarantee that the spreader is ready for use at the beginning of the next season.

PTO DRIVE LINE

WARNING: BEFORE ATTEMPTING TO OPERATE THIS SPREADER, READ AND STUDY ALL SAFETY INFORMATION. IN ADDITION, MAKE SURE THAT EVERY INDIVIDUAL WHO OPERATES OR WORKS WITH THE SPREADER, WHETHER FAMILY MEMBER OR EMPLOYEE, IS FAMILIAR WITH THESE SAFETY PRECAUTIONS.

WARNING: DISCONNECT PTO DRIVE SHAFT AND HYDRAULIC HOSES (RELIEVE HYDRAULIC PRESSURE) BEFORE CLEANING, ADJUSTING, LUBRICATING OR SERVICING THIS SPREADER. FAILURE TO HEED MAY RESULT IN SERIOUS PERSONAL INJURY OR DEATH.

The Meyer V-Max Spreader is equipped with a cutout type clutch on the implement half of the PTO drive line. The clutch is designed to limit the amount of torque transferred to the machine through the drive line. If excessive torque is developed the clutch will disengage. A loud ratcheting sound will be heard and the transfer of power to the machine will be disrupted. To re-engage the machine simply shut down the PTO and allow the drive line to come to a stop. The PTO can then be re-engaged to restart the spreader. The cutout clutch will either re-engage upon shut down of the PTO or just before it comes to a complete stop.

The cutout clutch will disengage if start up is done in an abrupt or reckless manner. It also will disengage from foreign materials entering the spinner area of the spreader. It may also be possible to disengage the clutch by overloading or flooding the spinners with free flowing or liquid manure. If PTO clutch fails to re-engage it will be necessary to remove the foreign object from the spreader before restarting. **THERE IS NO FIELD ADJUSTMENT ON THE CUTOUT CLUTCH.**

DANGER: NEVER ENTER THE SPREADER BOX FOR ANY REASON WITHOUT FIRST PERFORMING THESE STEPS:

- STOP THE TRACTOR, SHUT THE TRACTOR OFF AND REMOVE THE KEY.
- SET THE PARKING BRAKE AND DISCONNECT THE PTO DRIVE LINE FROM THE TRACTOR.
- DO NOT ALLOW OTHERS IN THE BOX.

ROTATING AUGERS CAN CRUSH AND DISMEMBER. FAILURE TO HEED MAY RESULT IN SERIOUS PERSONAL INJURY OR DEATH.

DRIVE LINE ATTACHMENT

The cutout clutch end of the PTO drive line must always be attached to the implement. The PTO drive line is equipped with a 1 3/8-6, 1 3/8-21 or 1 3/4-20 spline on the implement half for attaching to the spreader. Remove the M17-hexagon bolt from the splined hub and slide the PTO onto the implement splined input shaft. Install the hexagon bolt through the hub being sure the bolt is falling into the groove on the splined shaft. Torque tight using a metric size M17 6-point socket and torque down to 75 ft. lbs. **A M17 6-POINT METRIC SOCKET MUST BE USED AS ROUNDING OF HEXAGON BOLT AND INACCURACY OF TORQUE SETTINGS COULD OCCUR.**

If removal of the M-17 hexagon bolt is necessary, use the same M-17 6-point socket and loosen bolt 1/2 turn. Insert a 1/4" drift punch in the hole on the opposite side of the hexagon bolt and tap to loosen the seated portion of the bolt from the splined hub. Repeat in 1/2 turn increments until loose. After bolt seat has been released, remove the bolt. If bolt is not unseated, damage to the hexagon bolt will occur.

Attach the shield safety chain to a suitable area on the spreader, preferably to the implement PTO steel shield.

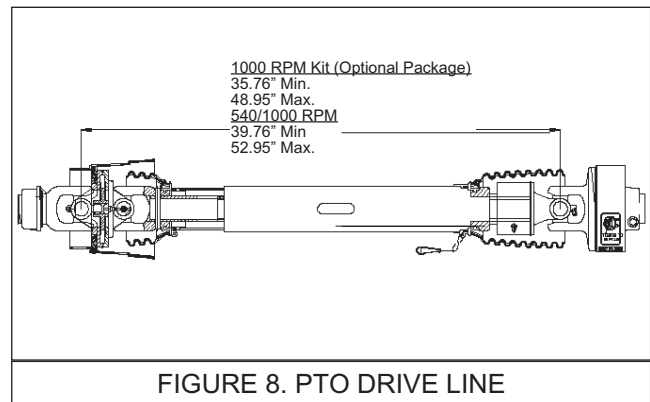

DANGER: NEVER ENTER THE SPREADER BOX FOR ANY REASON WITHOUT FIRST PERFORMING THESE STEPS:

- STOP THE TRACTOR, SHUT THE TRACTOR OFF AND REMOVE THE KEY.
- SET THE PARKING BRAKE AND DISCONNECT THE PTO DRIVE LINE FROM THE TRACTOR.
- DO NOT ALLOW OTHERS IN THE BOX.

ROTATING AUGERS CAN CRUSH AND DISMEMBER. FAILURE TO HEED MAY RESULT IN SERIOUS PERSONAL INJURY OR DEATH.

Adjust the drawbar at 15-22" above the ground. Extend or shorten the drawbar so horizontal distance from end of tractor PTO shaft to center of hitch pin hole is 14" for 540 RPM 1-3/8-6 spline, (16" for optional 1000 RPM 1-3/8-21 spline). Secure the drawbar so the hitch pin hole is located directly below the PTO drive line. PTO adapters are not recommended as damage to the drive line may occur. A hitch pin with a minimum diameter of 1" and bottom retaining pin is recommended.

AN IMPROPERLY LOCATED HITCH POINT MAY CAUSE DAMAGE TO THE UNIVERSAL JOINTS OF THE PTO DRIVE SHAFT. CONFORMING TO THE DRAWBAR AND PTO RELATIONSHIP SHOWN ON FIGURE 1, PAGE 8 WILL ENSURE THAT THE PTO DRIVESHAFT WILL NOT BECOME OVER EXTENDED. USE THE CORRECT SETTING FOR 14" - 540RPM 1 3/8-6 or 16" - 1000RPM 1 3/8-21. WITH INITIAL HOOK-UP TO YOUR NEW MEYER SPREADER TEST PTO TRAVEL BY TURNING EQUIPMENT IN BOTH DIRECTIONS OBSERVING THE MINIMUM AND MAXIMUM TRAVEL DIMENSIONS AS SHOWN PER DRAWING ON FIGURE 8, PAGE 15.

LUBRICATION

LUBRICATION

A high quality Lithium Base Grease should be used

PRIOR TO USE

- A. Using the CV Zerk (Key #2) place 20 pumps of grease into the CV center housing. This should be done with the drive line / CV as straight as possible.
- B. Slowly articulate the double joint through its maximum joint angle several times.
- C. Return the CV joint to its straight position and insert additional grease into the CV Zerk (Key #2) until grease is evident around the housing and center sliding disk.

NORMAL OPERATION

- A. Lubricate the following items after every eight (8) hours of operation. If short rows and frequent turning or other demanding conditions exist, lubricate at four (4) hour intervals.
 1. Cross and bearings (Key #1)-Add grease until it is purged around the seals.
 2. CV center housing (Key #2)-Add grease until it is evident around the center sliding disk.

3. Telescoping members (Key #3)-Add grease until it adequately covers the sliding members. Take apart occasionally to make sure adequate lubrication is being added.

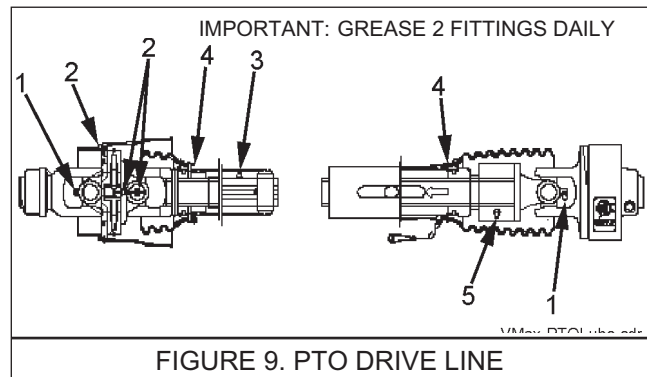

4. Shield bearings (Key #4)-Add 2-3 pumps.
5. Over-running clutch (Key #5) Add 10 pumps every 25-30 loads.

FAILURE TO FREQUENTLY GREASE THE CV CENTER HOUSING AND TELESCOPING MEMBERS WILL REDUCE THE LIFE OF THE CV.

MAINTENANCE INFORMATION

It is extremely important to follow the maintenance guidelines. If telescoping members become hard to slide during normal operation, it is recommended the shaft be taken apart, cleaned with solvent and re-coated with grease before re-assembling. As a minimum it is important this be done after each season of use.

ADJUSTMENTS



WARNING: DISCONNECT PTO DRIVE SHAFT AND HYDRAULIC HOSES (RELIEVE HYDRAULIC PRESSURE) BEFORE CLEANING, ADJUSTING, LUBRICATING OR SERVICING THIS SPREADER. FAILURE TO HEED MAY RESULT IN SERIOUS PERSONAL INJURY OR DEATH.

SPINNER MATERIAL GUIDES

Regularly inspect and adjust two spinner material guides located at both the LR and RR of the spreader. Create a 1/8-3/8" clearance between material guides and spinner teeth, figure 10. Maintain the recommended clearances for maximum spreading pattern. Adjust to prevent excessive manure build-up on material guide inner surfaces. Adjust to prevent manure chunks or foreign object lodging between material guides and spinner teeth.

NOTE: Excessive lodging can cause premature spinner tooth wear, "bent-over" or even breakage.

Adjustments for the 1/8-3/8" clearance of each material guide to spinner tooth is made by tightening or loosening the 1" nut on the material guide spring linkage shaft assembly. Tighten nut to increase clearance and loosen nut to decrease clearance between the material guides. Once recommended clearance is obtained turn spinners over by hand in the direction by which the spreader would turn to check clearance. Do not turn in the opposite direction as front chain tightener damage could occur.

Effective w/08 serial numbers

If foreign objects enter the spinner area, the rear pivot bolt on the shear arm is designed to shear. The 3/8-16x3" grade 5 replacement machine bolts are stored under the rear shield. For replacement install with 3/8" flat washer on top and on bottom of block and tighten nylon locknut firmly.

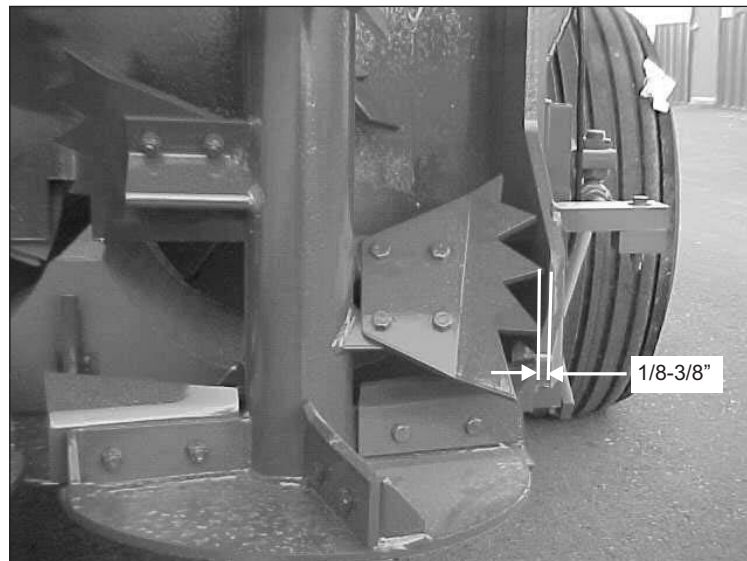

FIGURE 10. MATERIAL GUIDE CLEARANCE

! WARNING: DISCONNECT PTO DRIVE SHAFT AND HYDRAULIC HOSES (RELIEVE HYDRAULIC PRESSURE) BEFORE CLEANING, ADJUSTING, LUBRICATING OR SERVICING THIS SPREADER. FAILURE TO HEED MAY RESULT IN SERIOUS PERSONAL INJURY OR DEATH.

FRONT DRIVE ROLLER CHAINS

There are five roller chain drives located at the front of the spreader. Regularly check that all tensioning springs are in serviceable condition for automatic roller chain tightening. Manually adjust spring tensioners (as needed) by turning double locknuts on all tensioning bolt/idler assemblies. Proper roller chain tension is when 1/4" to 1/2" deflection occurs on the slack side of the chain. Regularly re-check all roller chain tensions. Keep all roller chains tight at all times! For clarity purposes, the following illustrations detail each roller chain reduction separately.

NOTE: The side bars of the roller chains will wear into the idler nylon rollers up to the rollers of the roller chain forming grooves. These grooves will serve as a guide when the roller chain loosens due to normal use. From this point on, after tightening, the idler nylon rollers should run for hundreds of hours without any noticeable wear.

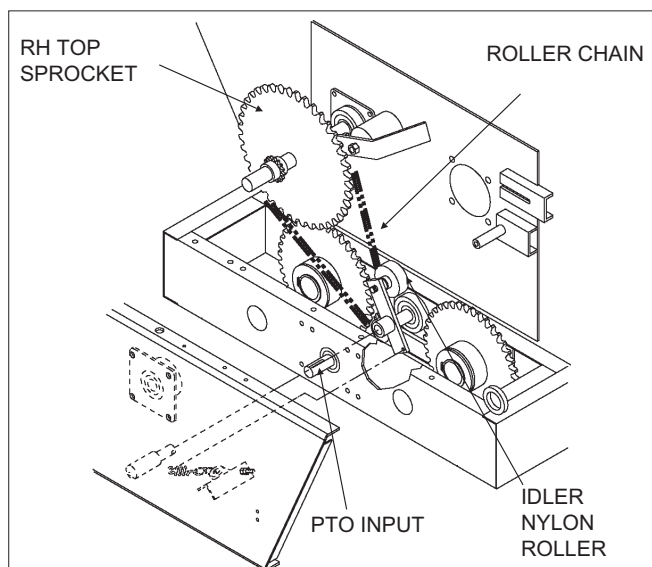

FIGURE 11. PRIMARY CHAIN DRIVE

SPRING LOADED ADJUSTER

The primary chain drive (PTO input shaft to the large RH top sprocket, figure 11) is automatically tensioned by a spring loaded idler nylon roller. The extension spring should extend 2" from its neutral 5" total length.

Manual adjustment for the automatic tensioning idler, nylon roller assembly is located at the left rear of the spreader's front bearing mounting plate.

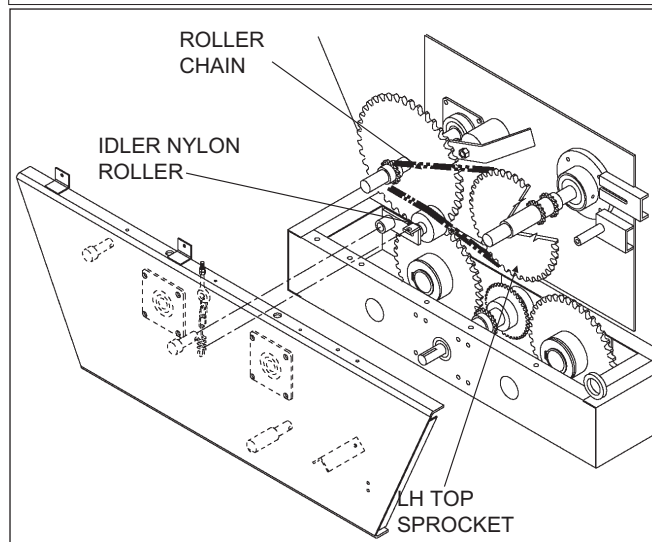

FIGURE 12. TRANSFER CHAIN DRIVE

SPRING LOADED ADJUSTER

The transfer chain drive (large RH top sprocket to the large LH top sprocket, figure 12) is automatically tensioned by a spring loaded idler nylon roller. The extension spring should extend 2" from its neutral 5" total length.

Manual adjustment for the automatic tensioning idler, nylon roller assembly is located at the front center of the spreader's front bearing mounting plate.

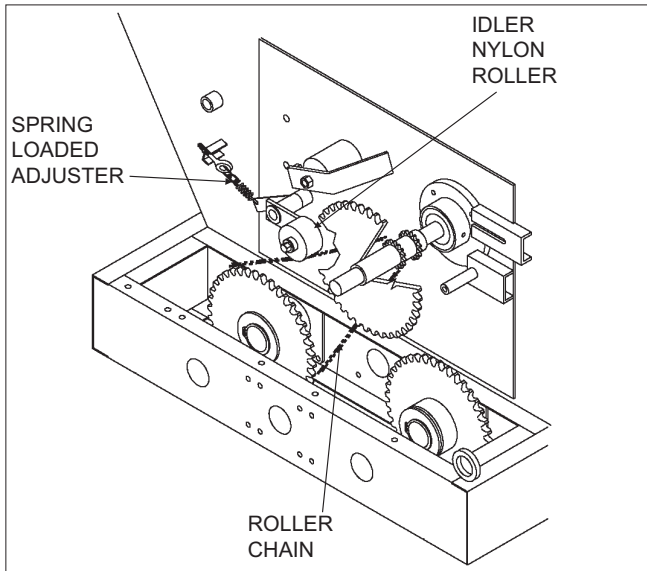

FIGURE 13. RH AUGER CHAIN DRIVE

RH AUGER SPROCKET

The RH auger chain drive, figure 13, is automatically tensioned by a spring loaded idler NYLON roller. The extension spring should extend $\frac{3}{4}$ " from its neutral 4" total length.

Manual adjustment for the automatic tensioning idler, NYLON roller assembly is located at the right front lower corner of the spreader tank.

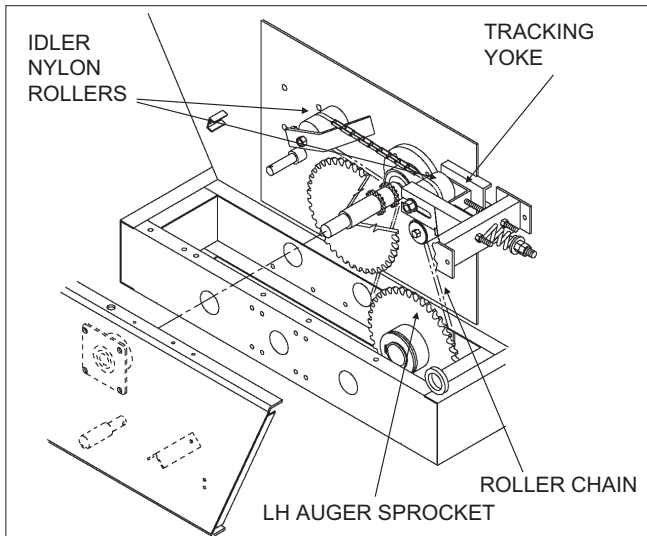

FIGURE 14. LH AUGER CHAIN DRIVE

COMPRESSION SPRING

The LH auger chain drive is automatically tensioned by a spring loaded heavy compression spring and tracking yoke/idler, NYLON roller assembly, figure 14. The one heavy compression spring should be compressed to $3\frac{1}{2}$ " to 4" in length.

Manual adjustment for the automatic tensioning idler, NYLON roller assembly is located at the left front corner of the spreader tank.

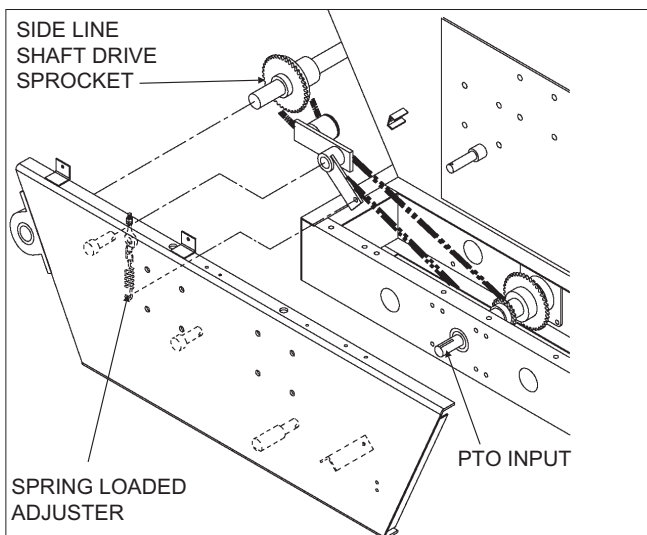

FIGURE 15. SIDE SHAFT CHAIN DRIVE

IDLER NYLON ROLLER

The side shaft chain drive (PTO input shaft to the side line shaft drive sprocket, figure 15) is automatically tensioned by a spring loaded idler NYLON roller. The extension spring should extend 2" from its neutral 5" total length.

Manual adjustment for the automatic tensioning idler, NYLON roller assembly is located at the right front of the spreader's front bearing mounting plate.

LUBRICATION



WARNING: DISCONNECT PTO DRIVE SHAFT AND HYDRAULIC HOSES (RELIEVE HYDRAULIC PRESSURE) BEFORE CLEANING, ADJUSTING, LUBRICATING OR SERVICING THIS MACHINE. FAILURE TO HEED MAY RESULT IN SERIOUS PERSONAL INJURY OR DEATH.

DAILY LUBRICATION (every 8-12 loads)

L1 Grease (2) rear spinner lower bearings. These bearings are grease line fitted to the LR frame channel of the spreader.

L2 Oil (5) roller chain drives regularly at the front of spreader with light weight machine oil. The roller chains are accessible by opening the front steel shielding cover.

L3 Grease PTO Drive line (9) places with Lithium grease every 8 hours. (See page 16 for further detail).

L4 Grease (4) bearings supporting the two large jack shaft reduction sprocket weldments on the front drive. The zerks are accessible by opening the front steel shielding cover and through the front bearing plate.

L5 Grease (2) auger shaft bushings. These bearings are grease line fitted to the RF shield of the spreader. Grease Daily, Minimum of 10 pumps. Over greasing is not possible.

WEEKLY LUBRICATION (every 25-30 loads)

L6 Grease (2) PTO input shaft bearings. These bearings are grease line fitted to the RF shield of the spreader.

L7 Grease bearings on the RH side line shaft. The front bearing is zerk accessible through the RF steel shielding. The remaining rear bearings are located along the RH side of the spreader tank, zerks accessible through the steel shielding.

L8 Grease (4) tandem wing pivots. Effectively grease by jacking up the spreader to relieve pressure points on the pivot shaft and tandem wing collar. Over greasing is not possible.

L9 Grease (2) flow control rear gate and lifting arm pivot points. Grease gate pivot at center of flow control rear gate. Grease lifting arm pivot support at LR of spreader. Over greasing is not possible. Apply grease to slot in gate lift arm.

L10 Grease (2) flow control rear gate slide guides. With the flow control rear gate opened, grease the slide guides from the zerks on the side. Allow grease to lubricate flow control rear gate ends and slide guide surfaces. In freezing weather dump used motor oil down each slide guide once a week or more often if needed. Over greasing is not possible.

L11 Grease (1) integral overrunning clutch at rear of the PTO drive line. The zerk is on the yoke of the clutch. Use Shell Super Duty or an equivalent lithium grease. (See page 16 for further detail).

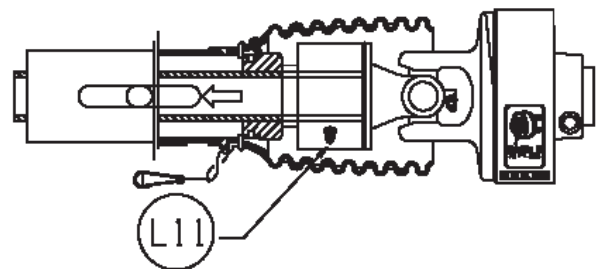

L12 Check regularly for any observable lube leakage of the (3) gearboxes at the rear of the spreader. See L12 under *Monthly Lubrication*.

MONTHLY LUBRICATION

L12 Keep the (3) gearboxes 1/2 full of liquid gear grease at all times, capacity approximately 30 oz. Check regularly for any observable leakage. If leakage is excessive, replace required input/output shaft seals as needed. Lubricate with a "Semi-Fluid, EP Lithium Base, Gear Grease".

L13 Clean and re-pack the wheel hubs with axle grease annually. Grease hub through zerk in hub monthly. Hub from factory has bearings packed but hub is not fully loaded with grease. Be careful not to over grease and force seal out of back side of hub.

L14 Grease (4) material guide pivot sleeves. Over greasing is not possible.

(5 ROLLER CHAINS)

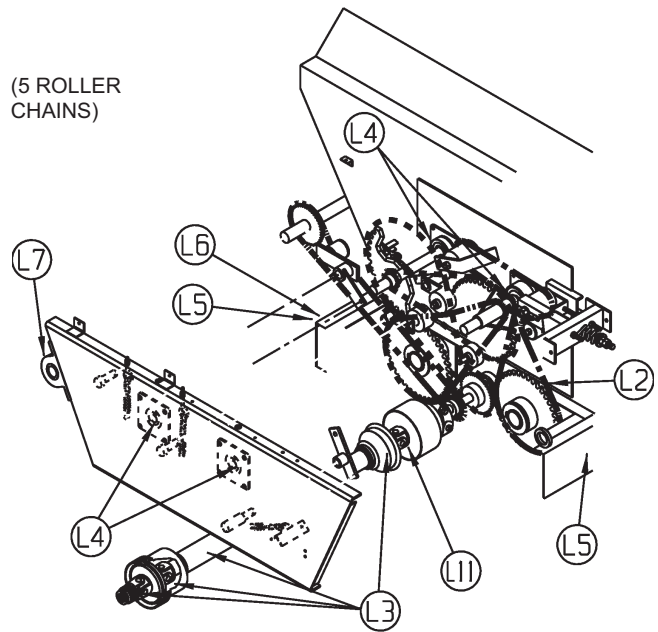

(SHIELDS REMOVED)

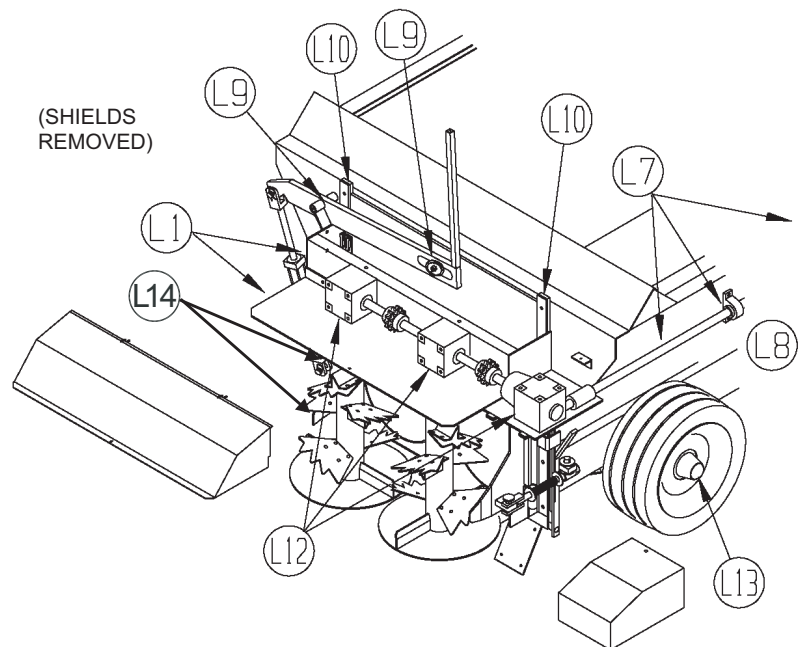

LUBRICATION & ADJUSTMENT FOR OPTIONAL 3RD AUGER

⚠ WARNING: DISCONNECT PTO DRIVE SHAFT AND HYDRAULIC HOSES (RELIEVE HYDRAULIC PRESSURE) BEFORE CLEANING, ADJUSTING, LUBRICATING OR SERVICING THIS MACHINE. FAILURE TO HEED MAY RESULT IN SERIOUS PERSONAL INJURY OR DEATH.

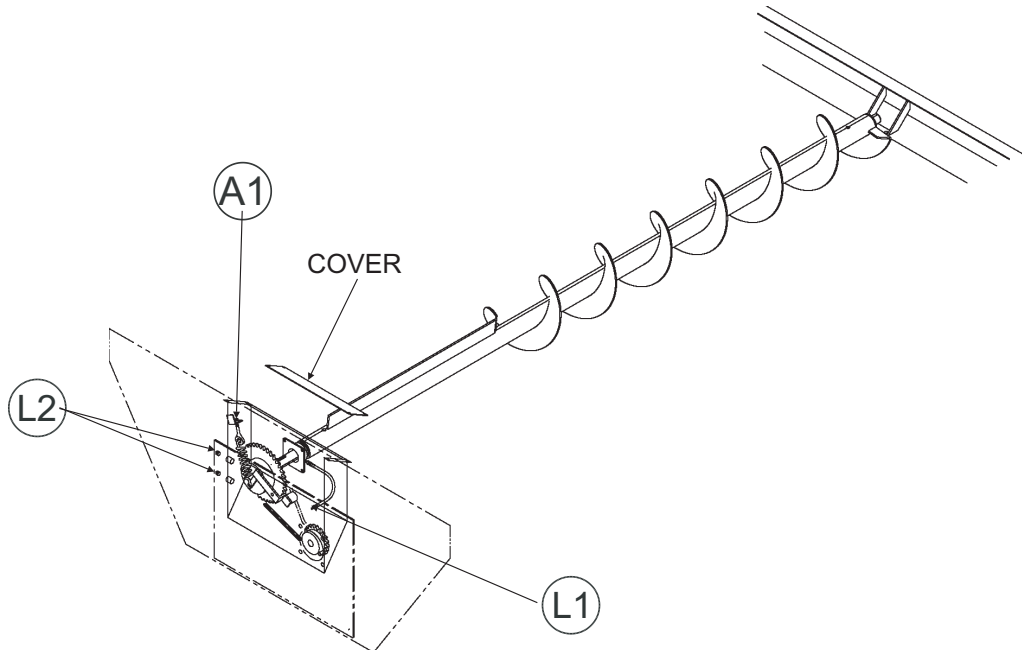

WEEKLY LUBRICATION (every 25-30 loads)

L1 Grease (1) bearing supporting the front shaft of the 3rd auger assembly. This bearing is grease line fitted to the spreader front, bearing back plate. The zerk is accessible by opening the front steel shielding cover.

SEASONAL LUBRICATION

L2 Maintain oil level in the (1) oil bath enclosure at the top, check plug line level. Check regularly for any observable leakage. If oil leakage is excessive, repair with silicone. Use #80-90 wt. gear lube oil or an equivalent. Lighter weight gear lube oil may be used in temperatures less than 20°F. **Change oil in the oil bath enclosure after the first season of use and regularly thereafter. (2.5 gallon capacity) Condensation can occur. Drain out water (bottom plug) as needed.**

- Remove lower plug for draining purposes.
- Remove reservoir cover or level plug for filling purpose. (SEAL COVER TIGHT WITH SILICONE WHEN RE-INSTALLING.)

ADJUSTMENTS

A1 The 3rd auger drive roller chain (large LH top reduction sprocket weldment to the 3rd auger) enclosed in the oil bath is automatically tensioned by a spring loaded idler/slide pipe. The tensioning, extension spring should extend 3/4" from its neutral 4" total length.

Manual adjustment for the automatic tensioning idler assembly is located at the RF, top of the oil bath enclosure just under the cover.

LUBRICATION FOR OPTIONAL TRUCK MOUNT MECHANICAL DRIVE SYSTEM



WARNING: DISENGAGE PTO POWER SOURCE, REMOVE KEY, AND RELIEVE HYDRAULIC PRESSURE BEFORE CLEANING, ADJUSTING, LUBRICATING OR SERVICING THIS MACHINE. FAILURE TO HEED MAY RESULT IN SERIOUS PERSONAL INJURY OR DEATH.

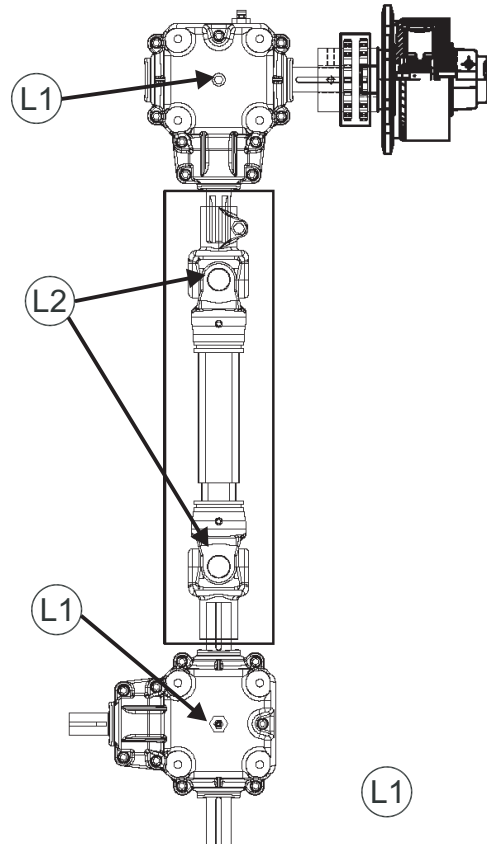

MONTHLY LUBRICATION

(L1) Keep the upper and lower gearboxes 1/2 full of 75W90 **Synthetic** oil, capacity approximately 30 oz. Check regularly for any observable leakage. If leakage is excessive, replace required input/output shaft seals as needed. **Use only synthetic 75W90 oil.**

DAILY LUBRICATION

(L2) Grease PTO driveline (2) places with lithium grease every 8 hours.

INSTRUCTIONS FOR OPTIONAL AUTOMATIC CHAIN OILER



WARNING: DISCONNECT PTO DRIVE SHAFT AND HYDRAULIC HOSES (RELIEVE HYDRAULIC PRESSURE) BEFORE CLEANING, ADJUSTING, LUBRICATING OR SERVICING THIS SPREADER. FAILURE TO HEED MAY RESULT IN SERIOUS PERSONAL INJURY OR DEATH.

The automatic chain oiler attachment gives a squirt of clean oil to all roller chains every time that the spreaders rear gate, hydraulic cylinder is activated. In this way, the spreaders roller chains get oiled in direct proportion to the number of hydraulic cylinder cycles of the rear gate. This assures adequate lubrication.

New 30 weight oil, which is placed in the reservoir tank mounted on the spreader, is all that is needed to properly lubricate all roller chains and sprockets. The automatic chain oiler does not use any oil from the tractors hydraulic system. The hydraulic hose connected to the bottom of the oiler pump only serves to power the piston in the pump every time that the spreaders rear gate is opened.

Should the oil reservoir tank run dry, pour about a 1/2 cup of clean 30 weight oil into the tank. Allow time for the oil to run down into the oiler pump slowly and allow air to escape. After thirty minutes to one hour has passed, finish filling the reservoir tank. Make sure that all fittings and brackets are tight when finished filling the tank.



WARNING: HYDRAULIC FLUID ESCAPING UNDER PRESSURE CAN HAVE SUFFICIENT FORCE TO PENETRATE SKIN. KEEP ALL HOSES AND CONNECTIONS IN GOOD SERVICEABLE CONDITION. FAILURE TO HEED MAY RESULT IN SERIOUS PERSONAL INJURY OR DEATH.

While running the tractors hydraulics only, open and close the spreaders rear gate several times. This will cycle the hydraulic cylinder leading to the oiler pump. Keep cycling until oil can be seen in all of the oil lines leading to the oiler brushes. (If you experience problems priming the oiler pump, you may need to bleed air out of the hydraulic hose where it is connected to the pump. Crack the fitting until oil comes out then re-tighten.) The hydraulic cylinder that the oiler pump is tied into is double acting and must reach 300 PSI of pressure to actuate the pump.

When replacing oiler brushes into brush holders, use regular 1/2"-20 nuts. Tighten nut finger tight initially as some adjustment may be needed later. For best results, place brush holders over top of roller chains and directly on top of sprockets. Adjust brush holders so oiler brushes are pushed down into the roller chain approximately 1/2". Carefully tighten up the 1/2"-20 nuts on the oiler brushes. DO NOT over tighten as damage to the brush will occur. The plastic threads of the oiler brush will crack and then break off from the brush body.

IMPORTANT! The 5/32" oil line tubing can only be removed from an oiler brush by pushing in on the red plastic ring and pulling the tubing out while holding the ring down.

The oiler pump is set at the factory to deliver the maximum amount of oil per cycle. If less oil is desired, loosen the jam nut on the bottom of the pump and screw in the adjusting shaft 1/4" or approximately 5 turns. It is not recommended to screw the shaft into the bottom of the oiler pump more than 15 turns as this may not allow for proper lubrication of the roller chains.

IMPORTANT! Always use new 30 weight oil. In cold weather, use a SAE 10 or a mixture of two parts of 30 weight oil to one part diesel fuel.

REPAIR PARTS

FRONT SHIELD & SIDE SHAFT DRIVE

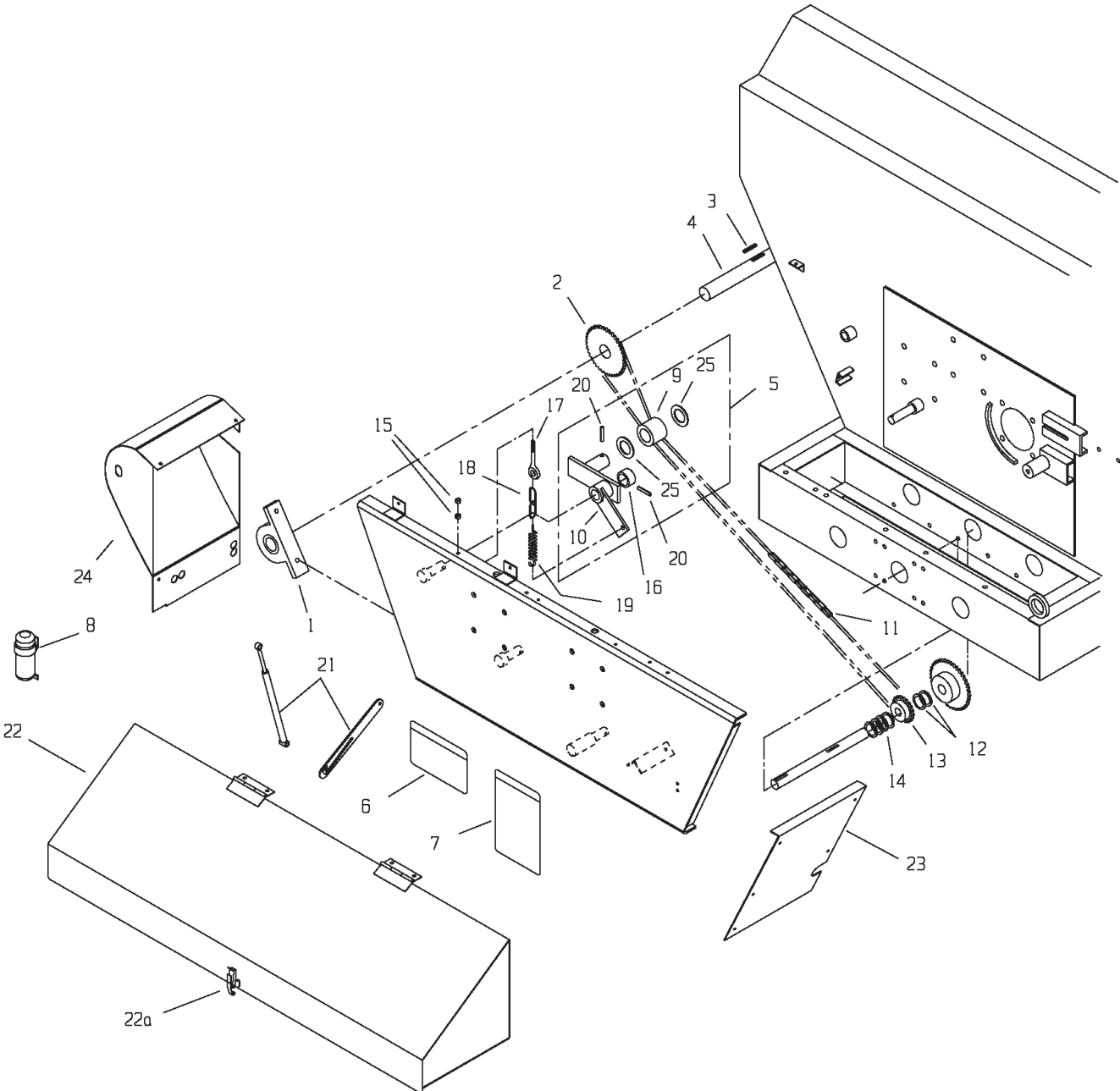

FRONT SHIELD & SIDE SHAFT DRIVE

KEY	PART NO.	DESCRIPTION
1	914-3801	1-3/8" Pillow Block Bearing
2	910-0013	80B18 Sprocket 1-3/8" Bore, 5/16" Keyway
3	935-0002	5/16 x 5/16 x 2 1/4" Hardened Key
4	923-3828	SV2636 Front Side Shaft
	923-3829	SV3245 Front Side Shaft
	923-3830	SV3954 Front Side Shaft
5	925-3882	Side Shaft Tightener Assy. Complete
6	46-3600-12	Operating Procedure Decal
7	46-3600-14	Maintenance Warning Decal
8	33-0044	Manual Holder W/Cap
9	912-0001	Nylon Roller
10	925-3882-1	Side Shaft Chain Tightener Weldment
11	911-0035	#80-95 Link Roller Chain (540 RPM, 1000 RPM Kit)
	911-0060	#80-93 Link Roller Chain (1000 RPM)
12	808-150-300-10	10 Ga. Machine Bushing (As Required)
13	910-0015	80B18 Sprocket 1-1/2" Bore, 3/8" Keyway (540 RPM, 1000 RPM Kit)
	910-0099	80B14 Sprocket 1-1/2" Bore, 3/8" Keyway (1000 RPM)
14	808-1.5-2.25-10	10 Ga. Machine Bushing (As Required)
15	813-3118-Z	5/16-16 Nut Zinc
16	808-1-1.5-18	18 Ga. Machine Bushing (As Required)
17	933-3804	5/16-18 x 4" Eye Bolt Fully Threaded
18	925-3822-6	2-Link 3/16" Proof Coil Chain (Prior To SN SV063245240)
19	929-0003	Tightener Spring
20	38-0013	5/16 x 1-3/4" Roll Pin
21	955-3703	Gas Assist Spring
	925-5006-1	Shield Support Arm (Serial # 08 & Later)
22	924-3821	Main Front Shield Assy. (Prior to 08 Serial #'s)
	924-3827	Main Front Shield Assy. (Serial # 08 & Later)(540 RPM, 1000 RPM Kit)
	924-3827-RPM	Main Front Shield Assy.(1000 RPM)
22a	32-0018-1	Heavy Duty Latch
23	924-3826	Left Front Shield
24	924-3820	Right Front Shield Welded Assy.
25	808-1.25-1.875-14	1-1/4 ID x 1-7/8OD x 14 Ga. Machine Bushing

AUGER DRIVE, PRIMARY REDUCTION

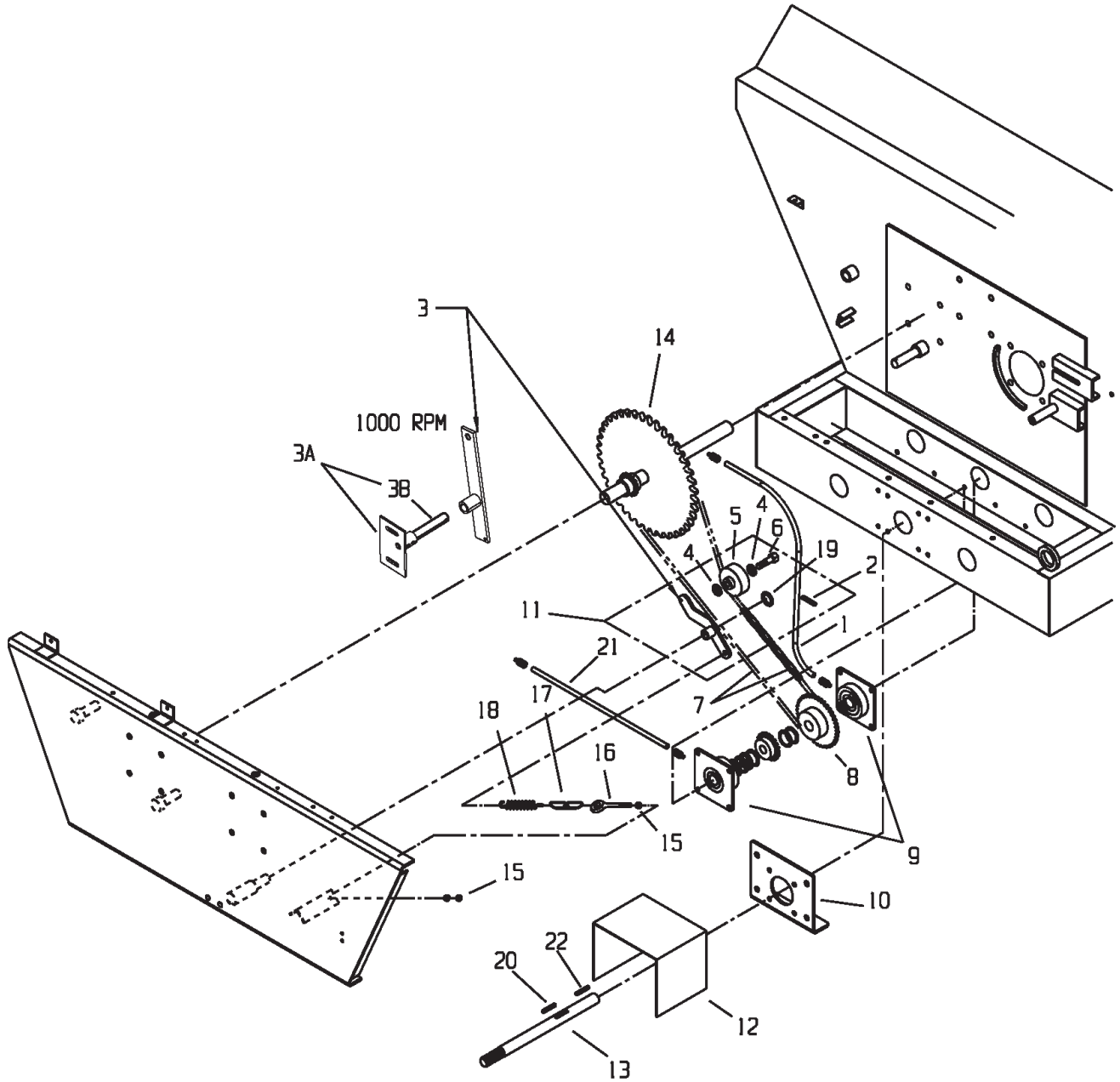

AUGER DRIVE, PRIMARY REDUCTION

KEY	PART NO.	DESCRIPTION
1	933-3628	Copper Tube Grease Line 25" (includes zerks, fittings)
2	38-0013	Roll Pin, 5/16" x 1-3/4"
3	925-3883-1	First Reduction Tightener Assembly Arm Weldment (540 RPM, 1000 RPM Kit)
	925-5015-1	First Reduction Tightener Assembly Arm Weldment (1000 RPM)
3A	925-5017	Pivot Mount Plate Assy. (1000 RPM)
3B	925-5017-3	Pivot Shaft Only (1000 RPM)
4	808-.75-1.25-14	Machine Bushing, 14GA (AR)
5	912-0012	Tightener Roller 1-3/8" Nylon Complete
5A	912-0012-1	Nylon Roller Only
5B	912-0012-2	Inner Sleeve
6	851-7510-2Z	3/4"-10x2" Bolt, GR 5 (540 & 1000 RPM Kit)
	925-3717-3	3/4"-10x2"-1/4" Bolt, GR 5 Machined Special (1000 RPM Models)
7	911-0032	Chain #80x86 pitches (540 RPM, 1000 RPM Kit)
	911-0072	Chain #80x99 pitches (1000 RPM)
8	910-0039	Sprocket 80B22 1-1/2" Bore, 3/8" Keyway (10 RPM on Augers) STANDARD
	910-0033	Sprocket 80B15 1-1/2" Bore, 3/8" Keyway (7 RPM on Augers)
	910-0005	Sprocket 80B12 1-1/2" Bore, 3/8" Keyway (5 RPM on Augers)
9	914-3602	Bearing 4 Bolt Flange, 1-1/2" Bore
10	925-3606	Front Bearing Plate-Bent
11	925-3883	1st Reduction Tightener Arm Assy (540 & 1000 RPM Kit)
	925-5015	1st Reduction Tightener Arm Assy (1000 RPM Models)
12	931-3810	CV/OR PTO Shied Assembly
13	923-3833	CV/OR Input Drive Shaft-Splined
13	923-3833-XL	CV/OR Input Drive Shaft (Opt 19" Ext Hitch)
14	910-0063	Welded Sprocket Assy, RH, 80A60x80A12 (540 RPM, 1000 RPM Kit)
	910-0063-RPM	Welded Sprocket Assy, RH, 80A80x80A12 (1000 RPM)
15	813-3118-Z	5/16" Regular Nut
16	933-3804	5/16"x4" Full Thread Eye Bolt
17	925-3822-6	2 Links 3/16" Proof Coil Chain (Prior To SN SV063245240)
18	929-0003	Spring
19	808-1-1.5-18	Machine Bushing, 18GA (AR)
20	35-0010	3/8"x3/8"x1-1/2" Square Key
21	933-3632	Copper Tube Grease Line 37" (includes zerks fittings)
22	935-0001	3/8 x 3/8 x 2" Hardened Key

AUGER DRIVE, SECONDARY REDUCTION

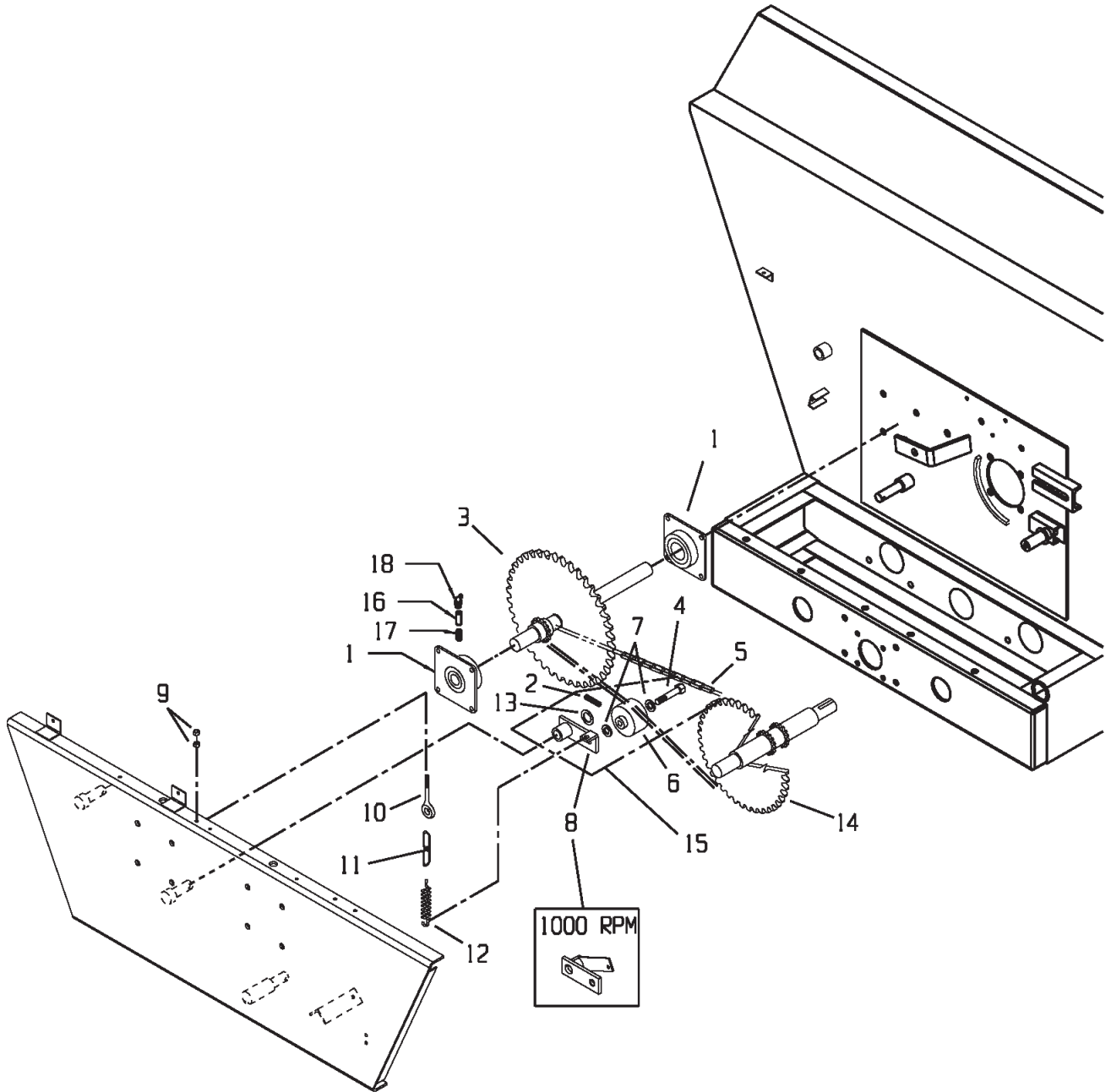

AUGER DRIVE, SECONDARY REDUCTION

KEY	PART NO.	DESCRIPTION
1	14-0031	Bearing, 4 Bolt, 2" Bore
2	38-0013	Roll Pin, 5/16" x 1-3/4"
3	910-0063	Welded Sprocket Assy, RH, 80A60x80A12 (540 RPM, 1000 RPM Kit)
	910-0063-RPM	Welded Sprocket Assy, RH, 80A80x80A12 (1000 RPM)
4	851-7510-3Z	3/4"-10x3" Bolt, GR5
5	911-0018	Chain #80x73 pitches (540 RPM, 1000 RPM Kit)
	911-0073	Chain #80x87 pitches (1000 RPM)
6	912-0013	Tightener Roller 2" Nylon Complete
6A	912-0013-1	Nylon Roller Only
6B	912-0013-2	Inner sleeve
7	808-.75-1.25-14	Machine Bushing, 14GA
8	925-3884-1	Second Reduction Tightener Arm Weldment
	925-3884-1-RPM	First Reduction Tightener Assembly Arm Weldment (1000 RPM)
9	813-3118-Z	5/16" Regular Nut
10	933-3804	5/16"x4" Full Thread Eye Bolt
11	925-3822-6	2 Links 3/16" Proof Coil Chain (Prior To SN SV063245240)
12	929-0003	Spring
13	808-1-1.5-18	Machine Bushing, 18GA
14	910-0064	Welded Sprocket Assy, LH, 80A60 x 120A9 (540 RPM, 1000 RPM Kit)
	910-0064-RPM	Welded Sprocket Assy, LH, 80A80 x 120A9 (1000 RPM)
15	925-3884	Tightener Assembly Complete (540 RPM, 1000 RPM Kit)
	925-3884-RPM	Tightener Assembly Complete (1000 RPM)
16	30-0009	1/8" NPT Coupler
17	30-0014	1/8" NPT x 3 1/2" Nipple
18	30-0002	1/8" NPT Zerk

RH AUGER DRIVE, FINAL REDUCTION

Install (#120-56) Roller Chain, Key #13
W/Connector Link Cotter Pins Facing
Towards **Front** Of Spreader.

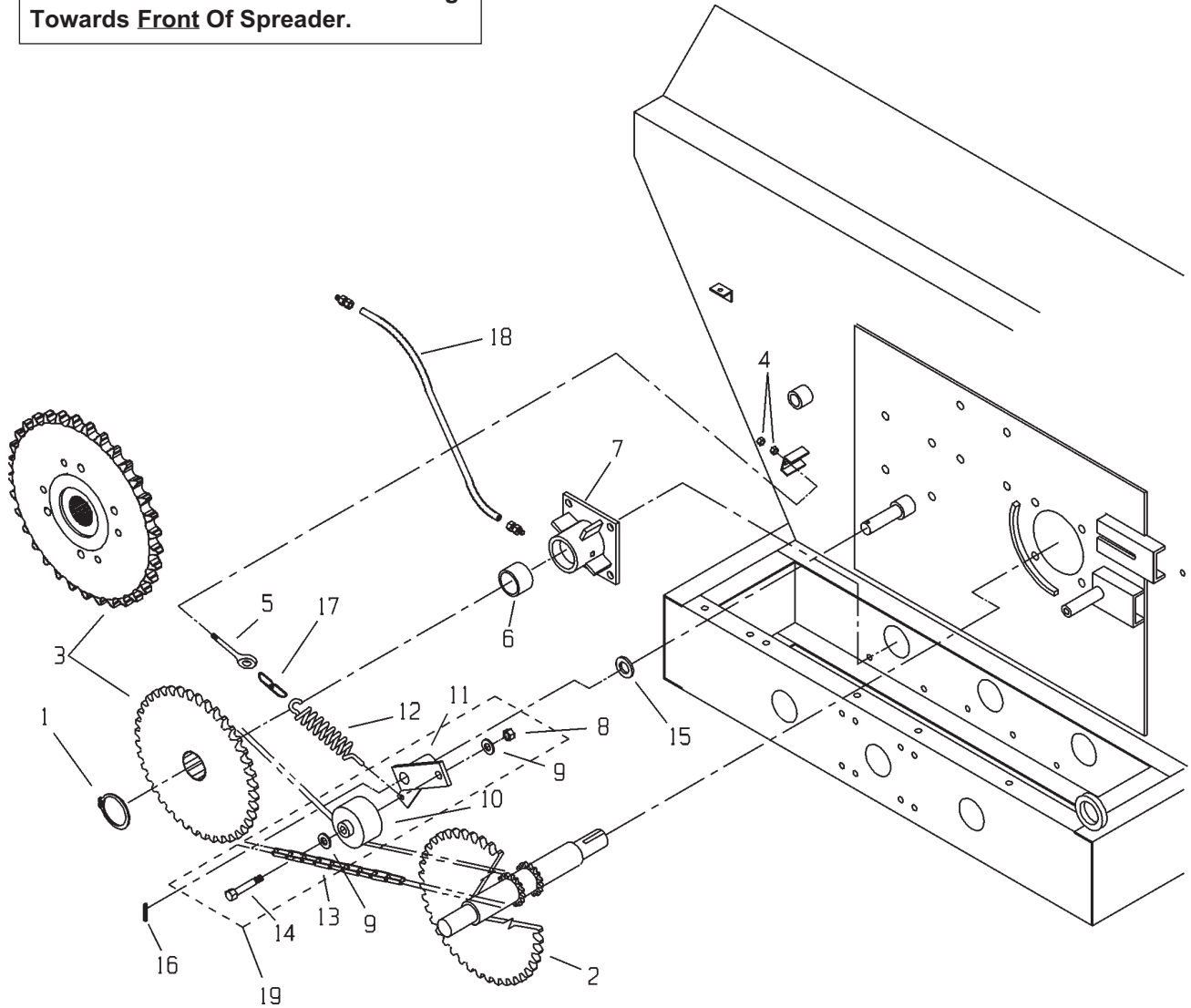

VMax-RHAugerDrive.cdr

RH AUGER DRIVE, FINAL REDUCTION

KEY	PART NO.	DESCRIPTION
1	33-0025	2-1/2" Retaining Ring
2	910-0064	Welded Sprocket Assy, LH, 80A60 x 120A9 (540 RPM, 1000 RPM Kit)
	910-0064-RPM	Welded Sprocket Assy, LH, 80A80 x 120A9 (1000 RPM)
3	910-0028	Auger Sprocket 120B33, Splined-Nonshear
	910-0101	Shear Sprocket Assembly 120B33 (Prior to SV112636402 & SV123954243 & Later)
	831-4420-1.75	7/16-20 x 1-3/4" Allen Head Cap Screw Grade 8 (SV073954331-335 Only)
	884-4420	7/16-20 Top Locknut Grade 8 (SV073954331-335 Only)
	831-5020-1.75	1/2-20 x 1-3/4" Allen Head Cap Screw Grade 8 (SV073954331-335, 350& Later)
	884-5020	1/2-20 Top Locknut Grade 8 (SV073954331-335, 350& Later)
	831-5618-1.75	9/16-18 x 1-3/4" Allen Head Cap Screw Grade 8 (SV073954350& Later)
	884-5618	9/16-18 Top Locknut Grade 8 (SV073954350& Later)
	910-0105	Shear Sprocket Assembly 120B33, 14 hole (SV112636402 Thru SV123954242)
	831-5013-1.75	1/2"-13 x 1-3/4" Allen head Cap Screw Grade 8 (Standard protection with 910-0105 sprocket)
	884-5013	1/2"-13 Top Locknut Grade 8
	831-5020-1.75	1/2"-20 x 1-3/4" Allen Head Cap Screw Grade 8 (Less protection with 910-0105 sprocket)
	884-5020	1/2"-20 Top Locknut Grade 8
	831-5013-1.75	1/2"-13 x 1-3/4" Allen head Cap Screw Grade 8 (Standard protection with 910-0105 sprocket)
	884-5013	1/2"-13 Top Locknut Grade 8
	831-5020-1.75	1/2"-20 x 1-3/4" Allen Head Cap Screw Grade 8 (Less protection with 910-0105 sprocket)
884-5020	1/2"-20 Top Locknut Grade 8	
4	813-3118-Z	5/16" Regular Nut
5	933-3804	5/16"x4" Full Thread Eye Bolt
6	913-3801-1	Auger Bushing Only 2-1/2" ID x 2-3/4" OD x 2 3/4" Long
7	925-3834	Front Auger Bearing Plate Assm. With Bushing, RH
8	933-3621	3/4" Jam Nut
9	808-.75-1.25-14	Machine Bushing, 14GA
10	912-0013	Tightener Roller, 2" Nylon Complete
10A	912-0013-1	Nylon Roller Only
10B	912-0013-2	Inner Sleeve
11	925-3848-7	Tightener Arm Welded Assy
12	929-3601	Spring
13	911-0023	Chain #120x56 pitches
14	851-7510-3.5Z	3/4"-10x3 1/2" Bolt, GR5
15	805-0010-Z	1" Flat Washer
16	38-0013	5/16"x1-3/4" Roll Pin
17	925-3822-6	2 Links 3/16" Proof Coil Chain
18	933-3619	Copper Tube Grease Line 28" (includes zerk, fittings)
19	925-3848	Tightener Arm Assy Complete

LH AUGER DRIVE, FINAL REDUCTION

Install (#120-72) Roller Chain, Key #21
W/Connector Link Cotter Pins Facing
Towards Rear Of Spreader.

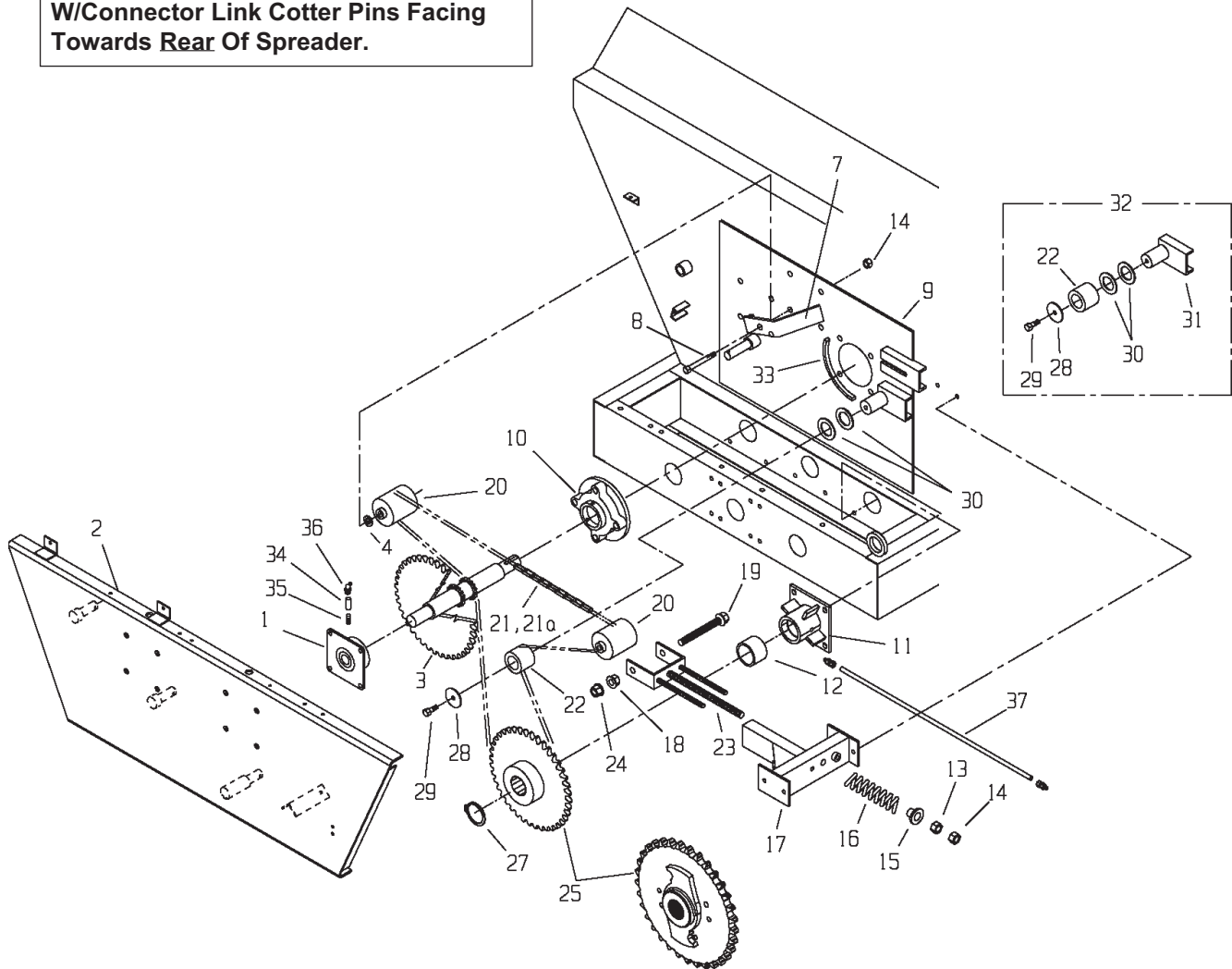

LH AUGER DRIVE, FINAL REDUCTION

KEY	PART NO.	DESCRIPTION
1	14-0031	Bearing, 4 Bolt Flange, 2" Bore
2	925-3873	Front Bearing Mounting Plate (540 RPM, 1000 RPM Kit)
	925-3873-RPM	Front Bearing Mounting Plate (1000 RPM)
3	910-0064	Welded Sprocket Assy, LH, 80A60 x 120A9 (540 RPM, 1000 RPM Kit)
	910-0064-RPM	Welded Sprocket Assy, LH, 80A80 x 120A9 (1000 RPM)
4	808-.75-1.25-14	Machine Bushing, 14GA
7	925-3846-2	4" Snugulator Support Arm Assy
8	851-7510-6Z	3/4"-10x6" Bolt, GR5
9	925-3870-1	Bearing Back Plate
10	914-3807A	Bearing, 4-Bolt, 2-1/2" Bore
11	925-3833	Front Auger Bearing Plate Assm. with Bushing, LH
12	913-3801-1	Auger Bushing Only 2-1/2" IDx2-3/4" ODx2 3/4" Long
13	813-7510-Z	3/4" Nut, Regular
14	933-3621	3/4" Jam Nut
15	925-3841	Spring Tightener Guide
16	29-0009	Spring, Compression
17	925-3885-1	Main Tightener Channel
18	925-3843	Inner Slide Nut Assembly
19	925-3839	3/4"x8 1/2" Bolt Assy
20	912-0014	Tightener Roller, 4" Nylon Complete
20A	912-0014-1	Nylon Roller Only
20B	912-0014-2	Inner Sleeve
21	911-0024	Chain #120x72 pitches
21A	911-0026	#120 Connector Link Only
22	912-0001	Nylon Roller
23	925-3838	Tightener Weldment Yoke
24	925-3842	Outer Slide Nut Assembly
25	910-0028	Auger Sprocket 120B33, Splined
	910-0101	Shear Sprocket Assembly 120B33 (Prior to SV112636402 & SV123954243 & Later)
	831-4420-1.75	7/16-20 x 1-3/4" Allen Head Cap Screw Grade 8 (SV073954331-335 Only)
	884-4420	7/16-20 Top Locknut Grade 8 (SV073954331-335 Only)
	831-5020-1.75	1/2-20 x 1-3/4" Allen Head Cap Screw Grade 8 (SV073954331-335, 350 & Later)
	884-5020	1/2-20 Top Locknut Grade 8
	831-5618-1.75	9/16-18 x 1-3/4" Allen Head Cap Screw Grade 8 (SV073954350 & Later)
	884-5618	9/16-18 Top Locknut Grade 8
	910-0105	Shear Sprocket Assembly 120B33, 14 hole (SV112636402 Thru SV123954242)
	831-5013-1.75	1/2"-13 x 1-3/4" Allen head Cap Screw Grade 8 (Standard protection with 910-0105 sprocket)
	884-5013	1/2"-13 Top Locknut Grade 8
	831-5020-1.75	1/2"-20 x 1-3/4" Allen Head Cap Screw Grade 8 (Less protection with 910-0105 sprocket)
884-5020	1/2"-20 Top Locknut Grade 8	
27	33-0025	2-1/2" Retaining Ring
28	925-3807-3	Nylon Roller Retaining Washer
29	851-5013-1.25Z	1/2"-13x1.25" Bolt, GR5
30	808-1.25-1.875-10	Machine Bushing, 10GA
31	925-3816-2	Chain Hold Down Bracket
32	925-3816	Roller Assembly
33	925-3869	Support For Bearing
34	30-0009	1/8" NPT Coupler
35	30-0014	1/8" NPT x 3 1/2" Nipple
36	30-0002	1/8" NPT Zerk
37	933-3637	Copper Tube Grease Line 51" (includes zerk, fittings)

BOX, AUGERS & SIDE SHAFT (1 OF 2)

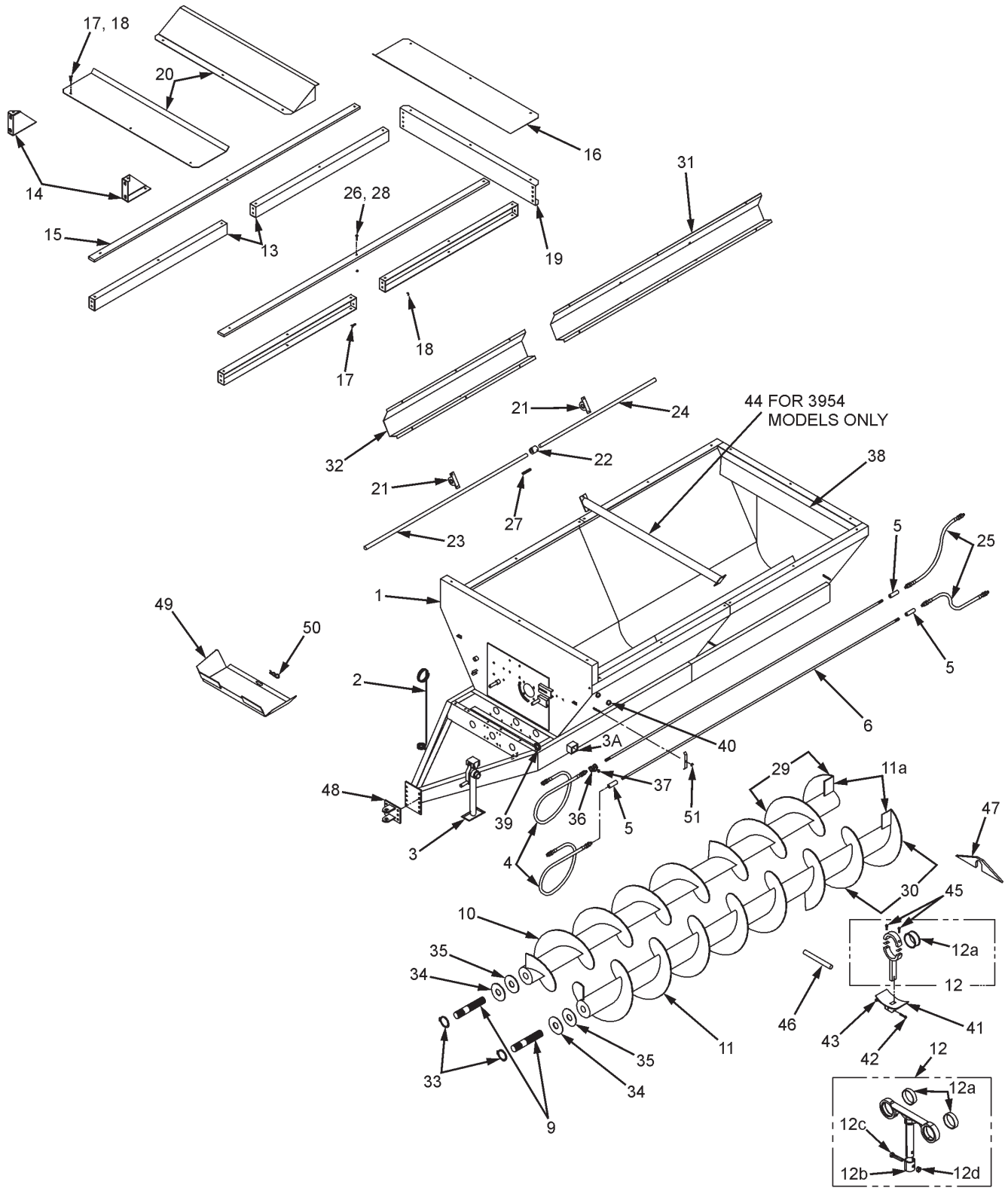

BOXASMPARTS-VMAX.CDR

BOX, AUGERS & SIDE SHAFT (1 OF 2)

KEY	PART NO.	DESCRIPTION
1	901-3803	Main Welded Body, 2636
	901-3802	Main Welded Body, 3245
	901-3801	Main Welded Body, 3954
2	929-3801	Hose Holder Spring
3	956-3803	Side Wind Jack
3A	956-3803-1	Square Jack Mount Tube
4	955-3611	Hydraulic Hose 108"
4A	55-0013	Male Tip Half Coupling
5	955-3609	Coupler 3/8"NPT
6	955-3805	Pipe Hydraulic, 2636
	955-3806	Pipe Hydraulic, 3245
	955-3807	Pipe Hydraulic, 3954
7	933-3602	Hydraulic Pipe Bracket Clamp
9	926-3801-5	Splined Shaft
10	926-3813	R. Side Auger, 2636 Prior to Ser. #SV063954524
	926-3825	R. Side Auger, 2636 Ser. #SV063954524 & Later
	926-3801-4	Splined Sleeve (Prior to Serial #SV082636416)
	926-3817-2	Splined Sleeve (Serial #SV082636416 & Later)
	926-3801-3	Hold In Slug
	926-3815	R. Side Auger, 3245 Prior to Ser. #SV063954524
	926-3823	R. Side Auger, 3245 Ser. #SV063954524 & Later
	926-3817-2	Splined Sleeve
	926-3801-3	Hold In Slug
	926-3817	R. Side Auger, 3954 Prior to Ser. #SV063954524
	926-3827	R. Side Auger, 3954 Ser. #SV063954524 & Later
	926-3817-2	Splined Sleeve
	926-3801-3	Hold In Slug
11	926-3814	L. Side Auger, 2636 Prior to Ser. #SV063954524
	926-3824	L. Side Auger, 2636 Ser. #SV063954524 & Later
	926-3816	L. Side Auger, 3245 Prior to Ser. #SV063954524
	926-3822	L. Side Auger, 3245 Ser. #SV063954524 & Later
	926-3818	L. Side Auger, 3954 Prior to Ser. #SV063954524
	926-3826	L. Side Auger, 3954 Ser. #SV063954524 & Later
11A	926-3801-8	Auger Flighting Support Gusset
12	901-3887	Auger Hold Down Wldmt w/brg. Single Ring Prior to Ser. #SV063954524
	901-3893	T-Post Auger Holddown Ser. #SV063954524 & Later
	901-3840-9	Steel Bearing Ring (Less Nylon)
	SV-HOLDDOWN-PKG	T-Post Holddown Update Kit (From Single Post Holddowns)
12A	901-3840-1	Nylon Bearing (2 per Auger)
12B	925-3771-4	Holddown Collar
12C	881-1008-5Z	1-08x5" M.B. Grade 8
12D	884-1008	1-08 Top Locknut Grade 8
13	901-3816-18	9" Extension Side Rail, 2636
	901-3816-20	9" Extension Side Rail, 3245
	901-3816-22	9" Extension Side Rail, 3954
14	901-3816-45	RH Splash Guard Gusset (No Ext)
	901-3816-46	LH Splash Guard Gusset (No Ext)

BOX, AUGERS & SIDE SHAFT (2 OF 2)

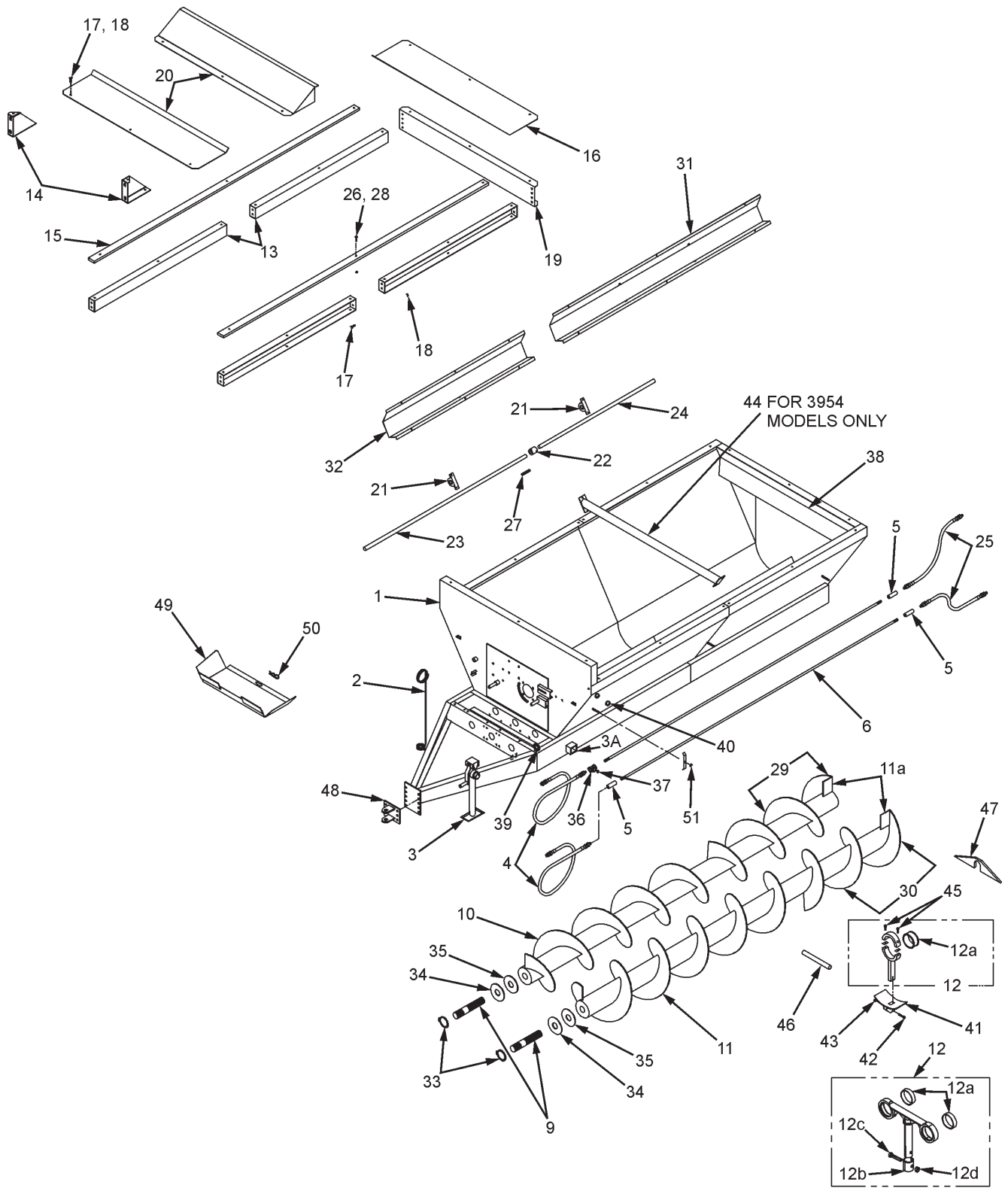

BOXASMPARTS-VMAX.CDR

BOX, AUGERS & SIDE SHAFT (2 OF 2)

KEY	PART NO.	DESCRIPTION
15	901-3816-27	Poly Board Top Rail, 2636
	901-3816-28	Poly Board Top Rail, 3245
	901-3816-29	Poly Board Top Rail, 3954
16	901-3830-5	Rear Splash Guard
17	851-5013-1.25Z	1/2"-13x1-1/4" Bolt, GR5
18	810-5013-Z	1/2" Flange Lock Nut
19	901-3816-30	Extension Back Rail
20	901-3830-5	Front Splash Guard (No Ext)
	901-3830-8	Front 45° Splash Guard (w/Ext)
21	914-3801	Pillow Block Bearing 1-3/8"
22	937-0002	Shaft Coupler 1-3/8"
23	923-3828	Shaft Front Side, 2636
	923-3829	Shaft Front Side, 3245
	923-3830	Shaft Front Side, 3954
24	923-3827	Shaft Rear Side
25	955-3833	3/8" Hyd. Hose w/Swivel
26	803-3816-1.5Z	Flat Head Socket Cap Screw
27	35-0017	5/16"x5/16"x4-1/2" Key
28	844-3816-Z	3/8" Flange Top Locknut
29	926-3802-2	3/8" Sectional Flighting x 20" RH
30	926-3801-2	3/8" Sectional Flighting x 20" LH
31	924-3822	Side Shaft Shield, Rear
32	924-3825	Side Shaft Shield, Front, 3954
	924-3824	Side Shaft Shield, Front, 3245
	924-3823	Side Shaft Shield, Front, 2636
33	33-0025	2-1/2" Retaining Ring
34	933-3802	Front Auger Washer - Steel (Prior to Serial #SV093954225)
35	933-3801	Bronze Washer (Prior to Serial #SV093954225)
	933-3801-NSM-09	Nylon Thrust Bearing 2-1/2x5x13/16" (Serial #SV093954225 & Later)
36	955-3803	3/8" Black T-Fitting
37	955-3809	3/8" Black Steel Plug
38	901-3843	Inner Rear Panel Support
39	901-3801-41	Hydraulic Hose Holder Ring
40	901-3801-40	Scraper Holder Ring
41	901-3888	Auger Hold Down Attaching Brkt
	901-3888-HD	Heavy Duty Auger Hold Down Attaching Brkt
42	881-6311-3	5/8"-11x3" Bolt, GR8
43	814-6311-Z	5/8"-11 Indented Locknut
44	901-3810-6	3954 Cross Support Pipe w/tabs
45	831-5013-1.5	1/2"-13x1 1/2 AHCS GR 8
46	901-3840-6	Hold Down Support Shaft
47	901-3840-7	Hold Down Shaft Support Gusset
48	901-3801-82	Adj. Hitch Plate, 1" Pin
49	924-5012-1	Sprk Shield (Std 3954) (Optional 2636, 3245)
50	823-.25-5Z	1/4x5 Hair Pin
51	810-3816-Z	3/8" Flange Lock Nut

UNLOADING GATE & TRIP PAN DOORS

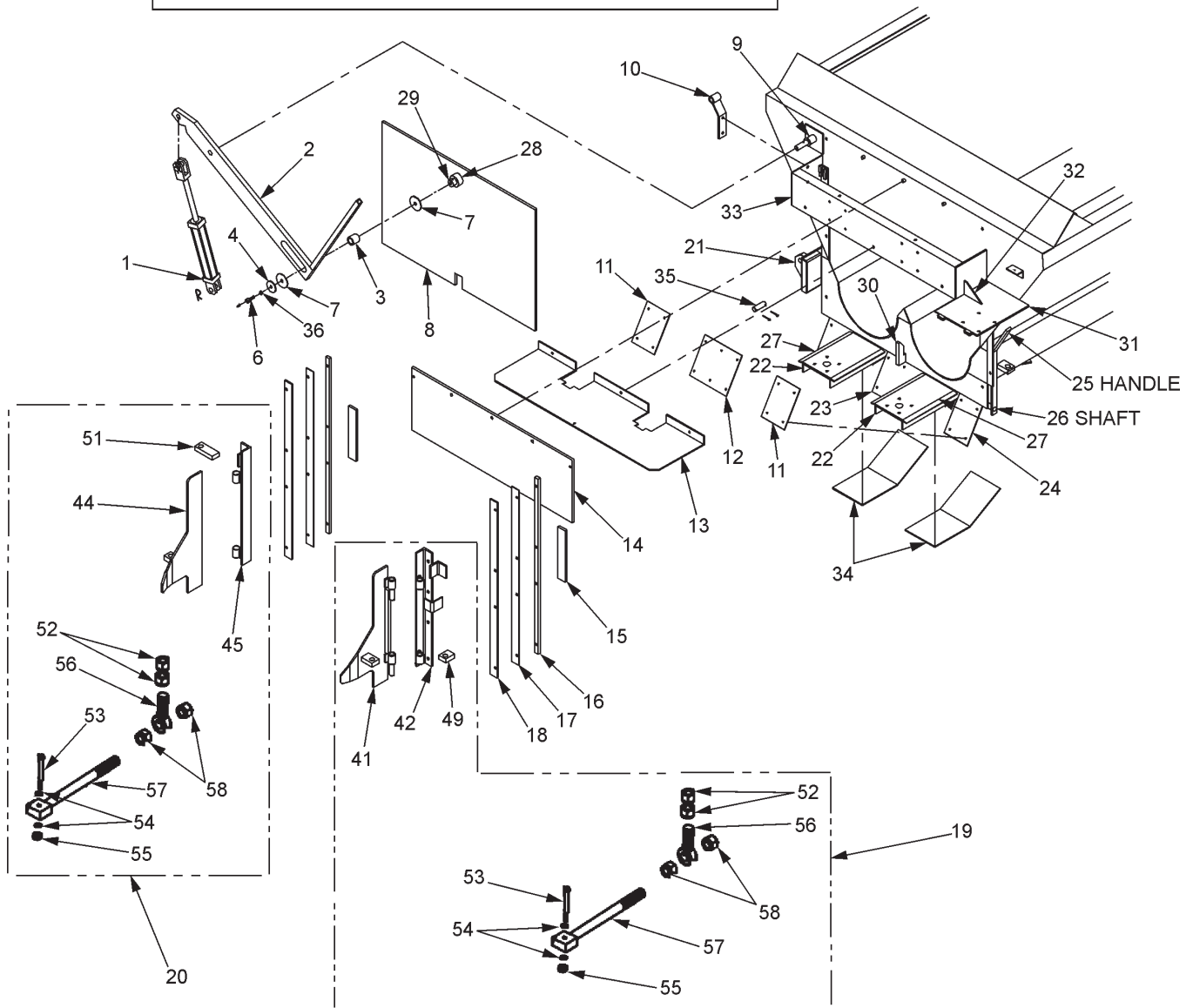
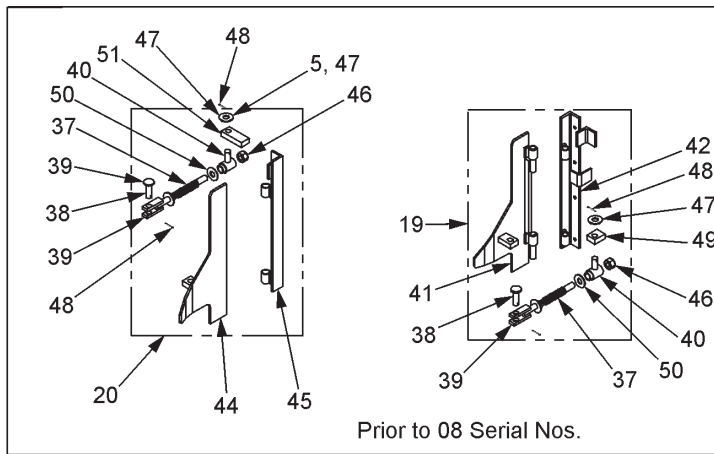

RearAsmParts-VMax.cdr

UNLOADING GATE & TRIP PAN DOORS (1 OF 2)

KEY	PART NO.	DESCRIPTION
1	955-3802-1	Hydraulic Cylinder
2	901-3837	Gate Lifting Arm W/Indicator
3	913-3807	Bushing, 954 Bronze
4	925-3807-3	Retaining Washer
5	30-0001	1/4"-28 Straight Grease Fitting
6	33-0030-RH	1/2x3/4" Drilled Grease Bolt
7	805-0125	1-1/4" ID Washer
8	901-3838	Flow Control Gate Complete
9	901-3839	Lift Arm Support Assembly
10	925-3853	Lifting Arm Support Bracket
11	925-3854-6	Outer Trap Door Poly Slick
12	925-3854-7	Center Trap Door Poly Slick
13	901-3845-1	Rear Shield Mounting Plate
14	901-3848	Upper Back Gate Poly Slick
15	901-3849	Back Gate Poly Slick Spacer
16	901-3847-1	Back Gate Slide Spacer
17	901-3847-3	Back Gate Slide Poly Slick
18	901-3847-2	Back Gate Slide Guide
19	925-3897	Right Material Guide Assy. Complete (Prior to 08 Serial #'s)
	925-3920	Right Material Guide Assy. Complete (08 Serial #'s & Later)
20	925-3898	Left Material Guide Assy. Complete (Prior to 08 Serial #'s)
	925-3921	Left Material Guide Assy. Complete (08 Serial #'s & Later)
21	901-3803-10	Lower Cylinder Pivot Plate Assy. (08 & Later Serial #'s)
	901-3803-10-OS	Lower Cylinder Pivot Plate Assy. (Prior to 08 Serial #'s)
22	901-3842-1	Spinner Mount channel
23	925-3854-4	Center Trap Door
24	925-3854-3	Outside Trap Door
25	925-3889-1	Trap Door Handle
26	925-3854-2	Trap Door Pivot Shaft
27	901-3842-3	Spinner Channel Poly Slick
28	901-3838-3	Gate Pivot Shaft Sleeve
29	901-3838-2	Gate Pivot Arm Shaft
30	901-3846	Back Gate Holder Hook
31	925-3852	Corner Gearbox Mounting Plate
32	901-3853	Corner Gearbox Support Gusset
33	901-3844-1	Gearbox Mounting Channel
34	925-3857	Rear Lower Skid Plate
35	955-3802-10	Cylinder Pivot Pin W/Clips
36	822-0050-Z	1/2" Split Lock Washer
37	29-0009	Adjustment Spring
38	925-3768-2	Spring Pivot Pin Assembly
39	925-3768-3	Spring Shaft Assembly
40	925-3768-4	Spring Pivot Sleeve Assembly
41	925-3897-2	Right Material Guide Outer Guide (Prior to 08 Serial #'s)
	925-3920-1	Right Material Guide Outer Guide (08 Serial #'s & Later)
42	925-3897-3	Right Mount Angle Assembly
43	925-3897-4	Pivot Pin (Not Shown Pre 2005 Serial #'s)

UNLOADING GATE & TRIP PAN DOORS

(2 OF 2)

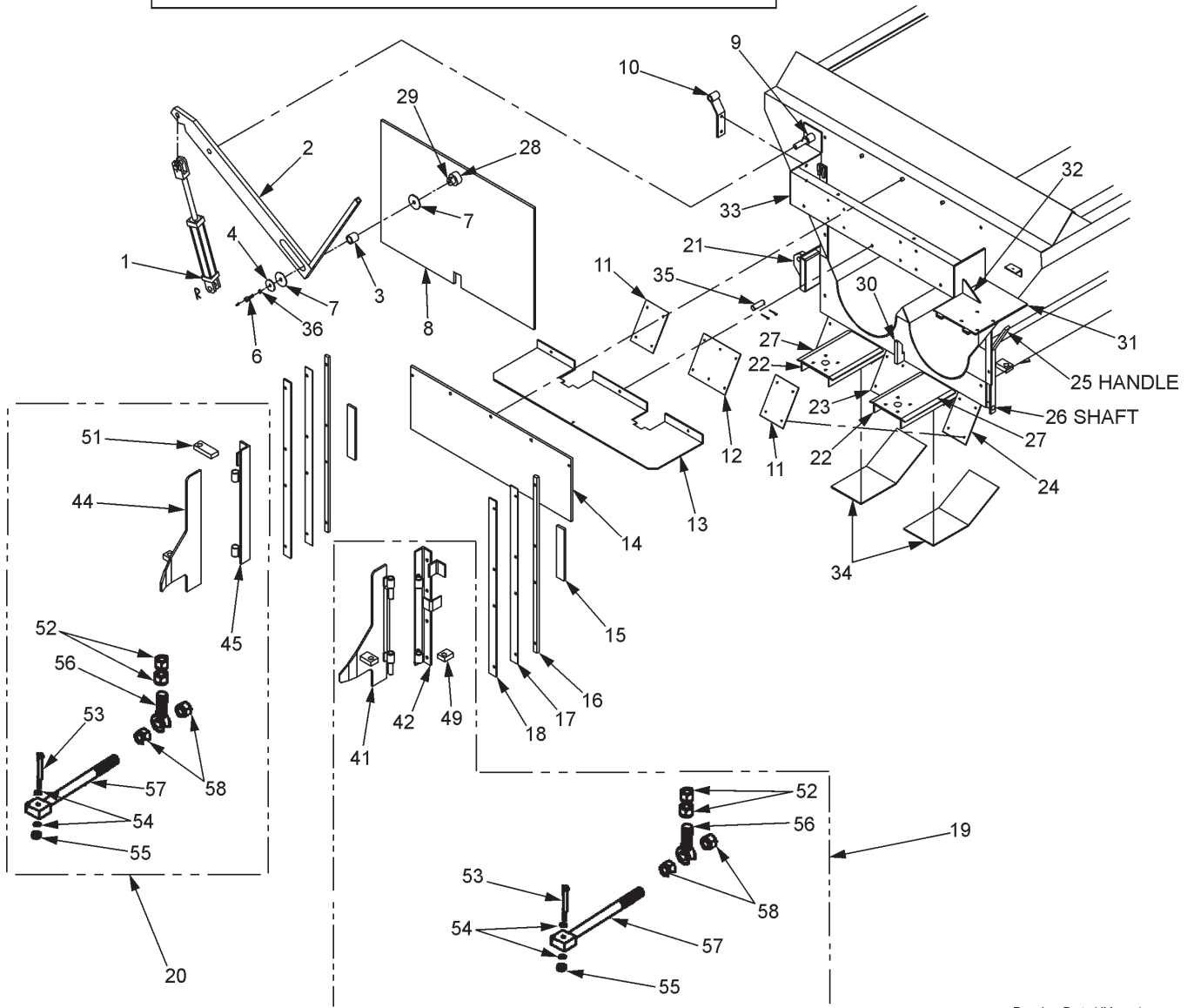
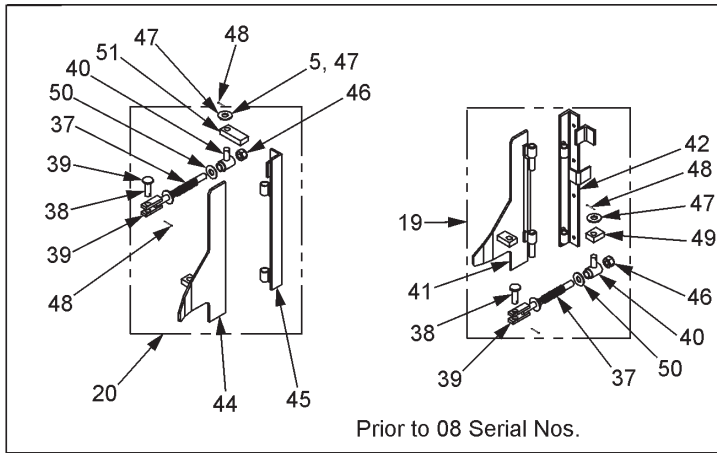

RearAsmParts-VMax.cdr

UNLOADING GATE & TRIP PAN DOORS (2 OF 2)

KEY	PART NO.	DESCRIPTION
44	925-3898-2	Left Material Guide Outer Guide (Prior to 08 Serial #'s)
	925-3921-1	Left Material Guide Outer Guide (08 Serial #'s & Later)
45	925-3898-3	Left Mount Angle Assembly
46	815-1008-Z	1-8 Nylon Insert Locknut
47	805-0010-Z	1" Flat Washer Zinc
48	823-25-2Z	1/4 x 2" Cotter Pin
49	901-3801-76	Right Material Guide Pivot Plate (Prior to 08 Serial #'s)
	925-5016-1	Right Material Guide Pivot Plate (08 Serial #'s & Later)
50	808-1.5-2.25-10	1-1/2 ID x 2-1/4 OD x 10 Ga. M.B.
51	901-3763-5	Left Material Guide Pivot Plate
52	75-0305-2	Jam Nut 1-14
53	851-3816-3Z	3/8"-16x3" Grade 5 Machine Bolt (08 serial #'s & Later)
54	805-0038-Z	3/8" Flat Washer (Prior to 08 serial #'s)
55	815-3816-Z	3/8"-16 Nylon Insert Locknut (Prior to 08 serial #'s)
56	75-0305-1	Right Hand Tie Rod Eye
57	925-5016	Shear Arm Welded Assy.
58	826-1008	1-08 Jam Nut

SPINNERS & GEARBOX SHAFT DRIVE

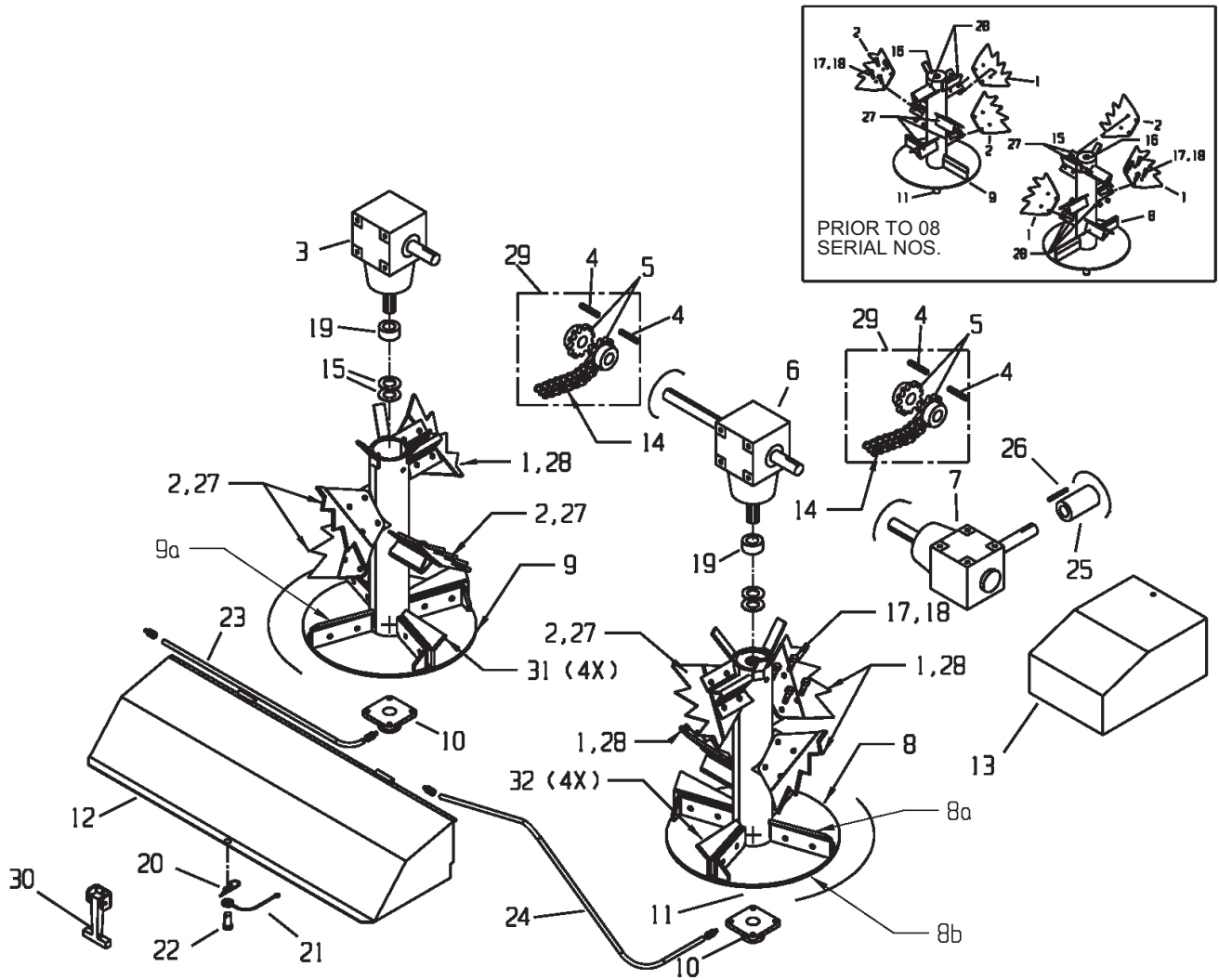

SPINNERS & GEARBOX SHAFT DRIVE

KEY	PART NO.	DESCRIPTION
1	901-3834-1	RH, 4-Point Tooth Paddle, 3/8", 4or3 Per RH Spinner (Lower), 2or1 Per LH (Upper)
2	901-3835-1	LH, 4-Point Tooth Paddle, 3/8" 4or3 Per LH Spinner (Lower) 2or1 Per RH (Upper)
3	19-0041	Gearbox, Left, Cast
	851-5013-1.5Z	1/2-13x1-1/2" Grade 5 M.B. Mount Bolts
	828-0050-Z	1/2" SAE Washer (2-per bolt)
	806-0050-Z	1/2" Internal Tooth Lockwasher
4	935-0002	5/16" x 5/16" x 2 1/4" Hardened Key
5	937-0014-1	Shaft Coupler, 1-3/8" Bore (4 Required)
6	19-0042	Gearbox, Center w/Thru Shaft, Cast
	851-5013-1.5Z	1/2-13x1-1/2" Grade 5 M.B. Mount Bolts
	828-0050-Z	1/2" SAE Washer (2-per bolt)
	806-0050-Z	1/2" Internal Tooth Lockwasher
7	19-0043	Gearbox, Right, Cast (540 RPM, 1000 RPM Kit) 1:1 Ratio
	19-0048	Gearbox, Right, Cast (1000 RPM) 1:1.35 Ratio
	851-5013-1.5Z	1/2-13x1-1/2" Grade 5 M.B. Mount Bolts
	828-0050-Z	1/2" SAE Washer (2-per bolt)
	806-0050-Z	1/2" Internal Tooth Lockwasher
8	901-3856-1	RH Spinner Assy, Less Paddles w/Bottom Shaft (Prior to 08 Serial #'s)
	901-3897-1	RH Spinner Assy, Less Paddles w/Bottom Shaft (08 Serial #'s & Later)
8a	901-3856-3	RH Paddle Backing Plate
8b	901-3855-5	Spinner Bottom Plate
9	901-3855-1	LH Spinner Assy, Less Paddles w/Bottom Shaft (Prior to 08 Serial #'s)
	901-3896-1	LH Spinner Assy, Less Paddles w/Bottom Shaft (08 Serial #'s & Later)
9a	901-3855-1-14	LH Paddle Backing Plate
10	914-3604	Bearing 4 Bolt Flange 1-3/8" Bore-Ductile
	851-5013-1.5Z	1/2"x1-1/2" Hex Bolt
	810-5013-Z	1/2" Spin Lock Nut
11	901-3855-8	Bottom Spinner Shaft
12	924-3817	Rear Shield Assembly (Prior to 08 Serial #'s)
	924-5011	Rear Shield Assembly (08 Serial #'s & Later)
13	924-3818	RR Shield Assembly
14	937-0009-2	Coupler Chain
	937-0009-3	Connecting Link
15	808-1.38-2.5-14	Machine Bushing, 14GA
	808-1.38-2.5-18	Machine Bushing, 18GA
	808-1.38-2.5-10	Machine Bushing, 10GA
16	901-3855-4	Splined Hub
17	851-5013-1.25Z	1/2"-13 x 1-1/4" Bolt, GR5
18	815-5013Z	1/2"-13 Nylon Insert Lock Nut
19	921-0001	1-3/8" One Piece Set Collar
20	32-0021	2" Hairpin Clip (Prior to 08 Serial #'s)
21	32-0022	6" Lanyard (Prior to 08 Serial #'s)
22	32-0023	3/8x3/4 Clevis Pin (Prior to 08 Serial #'s)
23	933-3626	Copper Tube Grease Line 31"
24	933-3625	Copper Tube Grease Line 55" (Includes zerks, fittings)
25	937-0002	Shaft Coupler, 1-3/8" Bore with 5/16" KQY w/4 Set Screws
26	35-0017	5/16" x 5/16" x 4 1/2" Key
27	901-3834-2	Left Hand Paddle Mount Brackets
28	901-3835-2	Right Hand Paddle Mount Brackets
29	937-0014	1 3/8" Coupler Assy. Kit w/Chain & Keys
30	32-0032	3-1/2" Rubber T-Latch w/catch (08 Serial # & Later)
31	901-3855-1-13	Left Lower Bolt On Paddle
32	901-3856-2	Right Lower Bolt On Paddle

SPINNER GEAR REDUCERS

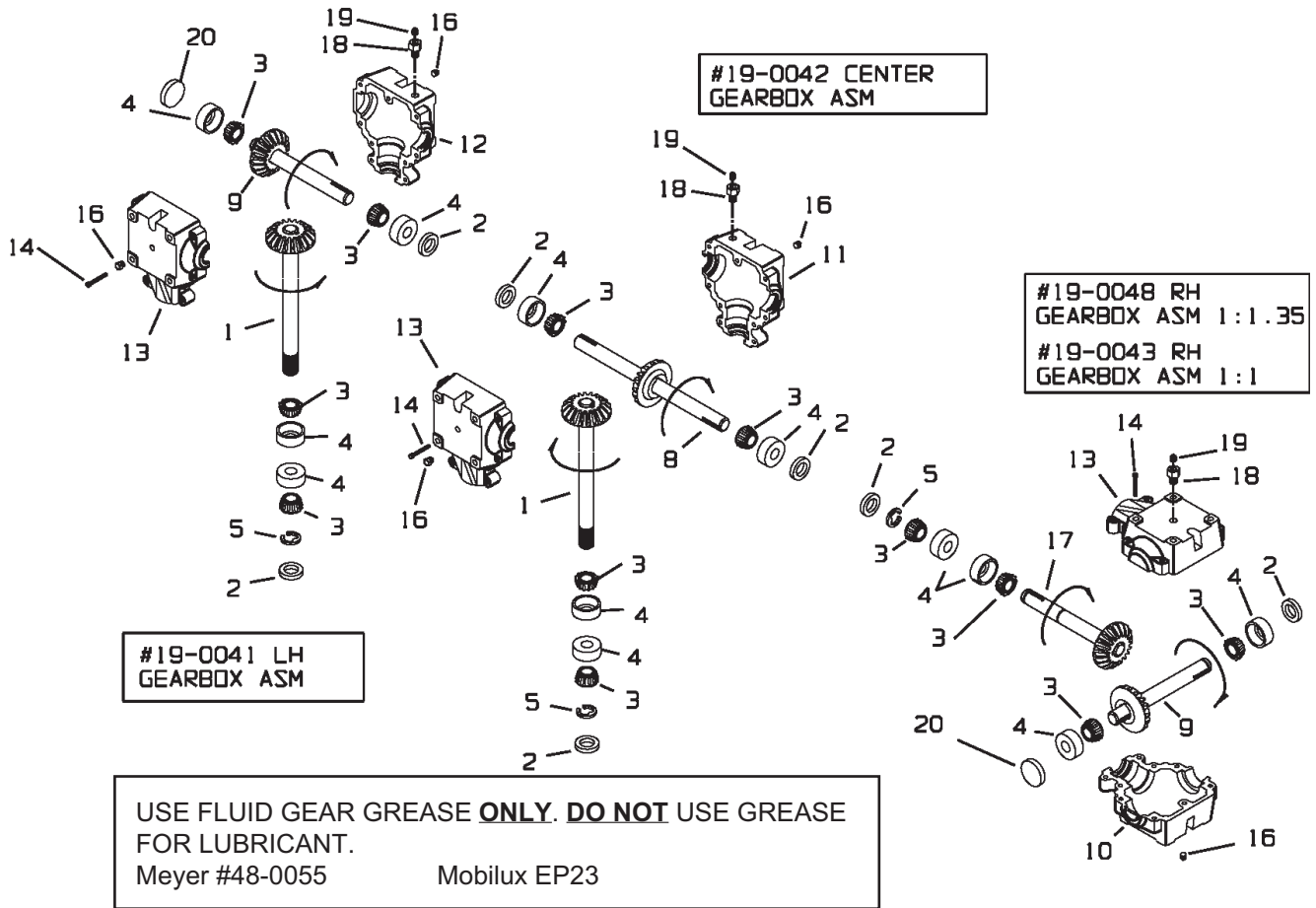

USE FLUID GEAR GREASE **ONLY**. DO NOT USE GREASE FOR LUBRICANT.
 Meyer #48-0055 Mobilux EP23

KEY	PART NO.	DESCRIPTION
1	19-0022-1-PF	Splined Pinion Output Shaft/Gear Assy
2	19-0018-2	Seal
3	19-0018-3	Bearing Cone
4	19-0016-3	Bearing Cup
5	19-0018-4	Retaining Ring
8	19-0022-2-PF	Center Gearbox Cross Thru Shaft/Gear Assy
9	19-0018-7-PF	RH/LH Gearbox Cross Input Shaft/Gear Assy (540 RPM, 1000 RPM Kit) 1:1 Ratio
	19-0048-1-PF	RH/LH Gearbox Cross Input Shaft/Gear Assy (1000 RPM) 1:1.35 Ratio
10	19-0043-1	Corner Gearbox Casting (tapped holes) Cast
11	19-0042-1	Center Gearbox Casting (tapped holes) Cast
12	19-0041-1	LH Gearbox Casting (tapped holes) Cast
13	19-0041-2	RH/LH/Center Gearbox Casting (thru holes) Cast
14	19-0024-20	Bolt 1 1/2" SHCS
16	19-0016-5	Plug 1/2"NPT Plain
17	19-0023-1-PF	RH Gearbox Pinion Output Shaft/Gear Assy (540 RPM, 1000 RPM Kit) 1:1 Ratio
	19-0048-2-PF	RH Gearbox Pinion Output Shaft/Gear Assy (1000 RPM) 1:1.35 Ratio
18	19-0023-2	3/8" Drilled Fill Plug Bolt
19	55-0107	Breather Plug
20	19-0041-3	Gearbox End Cap

19-0047 UPPER GEARBOX - TRUCK

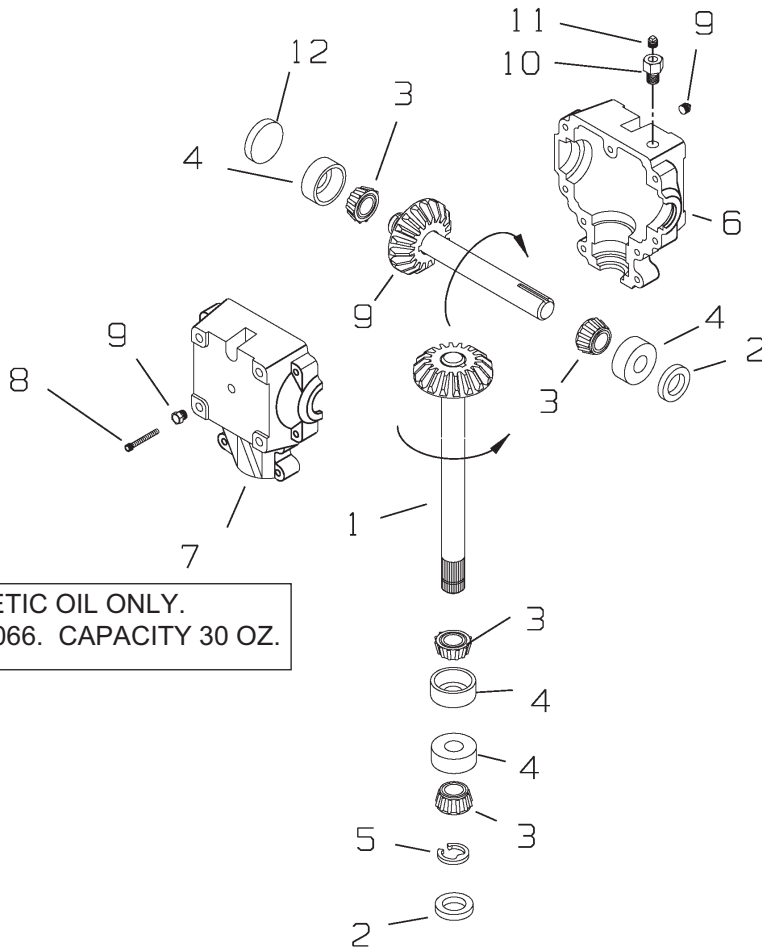

USE 75W90 SYNTHETIC OIL ONLY.
MEYER PART #48-0066. CAPACITY 30 OZ.

KEY	PART NO.	DESCRIPTION
1	19-0047-1-PF	Splined Pinion Output Shaft/Gear Assy. W/Groove
2	19-0018-2	Seal
3	19-0018-3	Bearing Cone
4	19-0016-3	Bearing Cup
5	19-0018-4	Retaining Ring
6	19-0041-1	LH Gearbox Casting (tapped holes) Cast
7	19-0041-2	Gearbox Casting (thru holes) Cast
8	19-0024-20	Bolt 1 1/2" SHCS
9	19-0016-5	Plug 1/2"NPT Plain
10	19-0023-2	3/8" Drilled Fill Plug Bolt
11	55-0107	Breather Plug
12	19-0041-3	Gearbox End Cap

#19-0038-SYN 2:1 RATIO GEARBOX LOWER GEARBOX - TRUCK

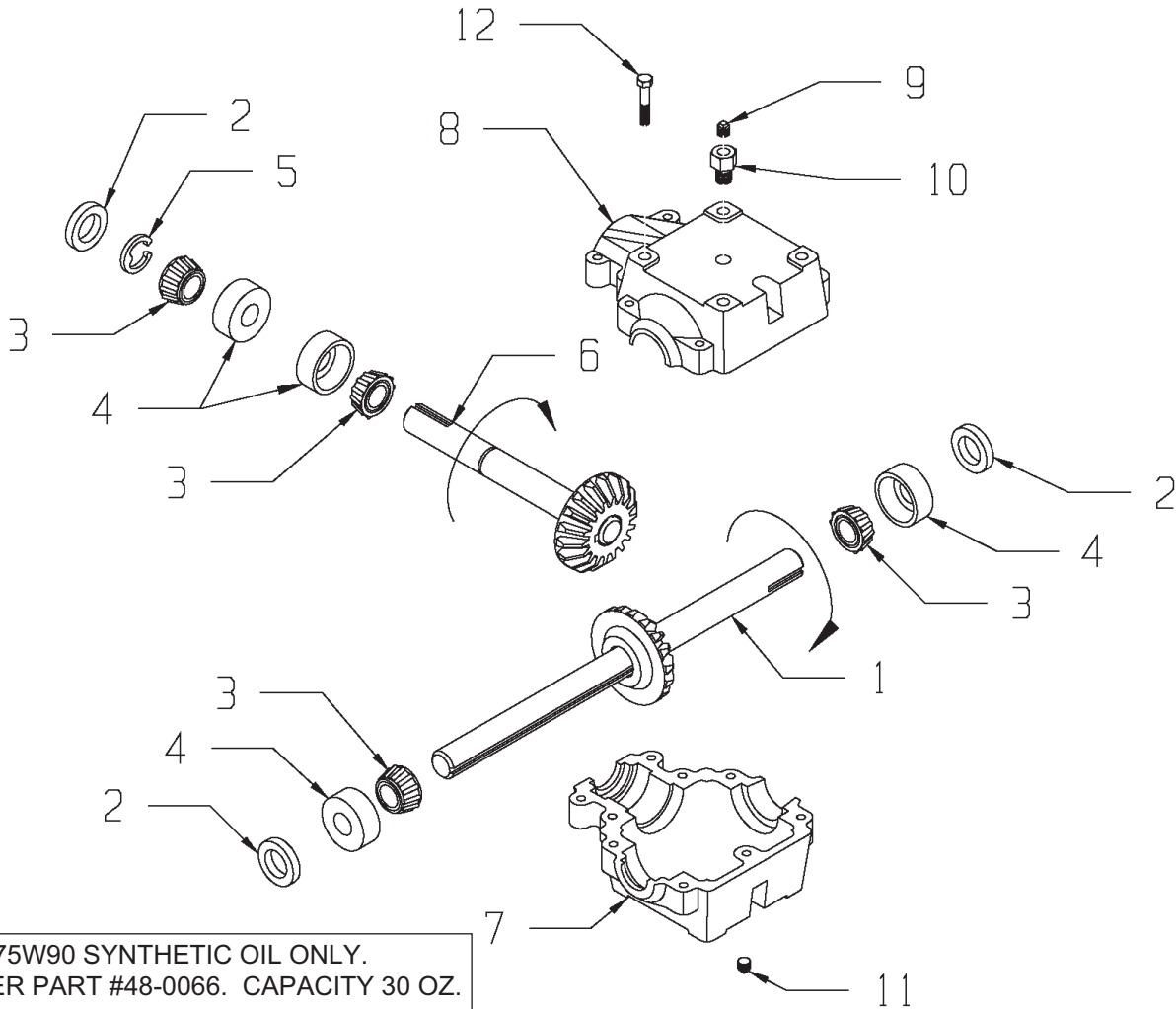

USE 75W90 SYNTHETIC OIL ONLY.
MEYER PART #48-0066. CAPACITY 30 OZ.

KEY	PART NO.	DESCRIPTION
1	19-0034-4	Output Shaft/Gear Assembly
2	19-0018-2	Seal
3	19-0018-3	Bearing Cone
4	19-0016-3	Bearing Cup
5	19-0018-4	Retaining Ring
6	19-0034-3	Input Shaft/Gear Assembly
7	19-0043-1	Gearbox Casting (Tapped Holes)
8	19-0041-2	Gearbox Casting (Thru Holes)
9	19-0002-17	Vent Plug, 5 PSI
10	19-0023-2	Bushing, 1/2-14 NPT
11	19-0016-5	Plug, 1/2-14 NPT
12	19-0016-11	Bolt, 3/8-16 x 1.50 SHCS

This Page Intentionally Blank

HUBS, AXLE & TANDEM AXLE ASSEMBLY

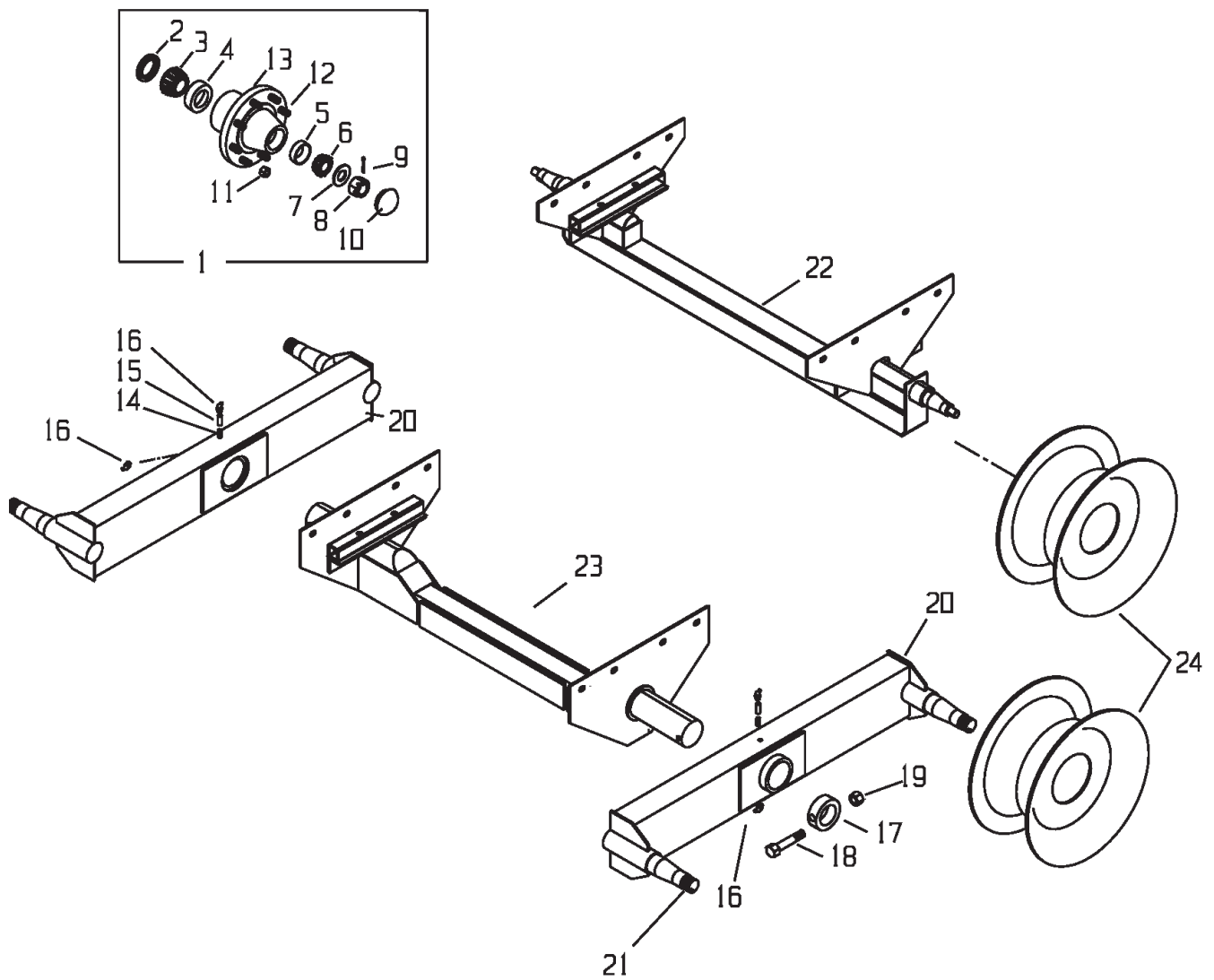

HUBS, AXLE & TANDEM AXLE ASSEMBLY

KEY	PART NO. M 3954	PART NO. M 2636&3245	DESCRIPTION
1	75-0207	75-0205	Hub Assembly Complete
2	75-0207-2	75-0205-2	Seal
3	75-0207-3	75-0205-3	Bearing Cone
4	75-0207-4	75-0205-4	Bearing Cup
5	75-0202-4	75-0202-4	Bearing Cup
6	75-0202-3	75-0202-3	Bearing Cone
7	75-0205-7	75-0205-7	Washer
8	75-0205-8	75-0205-8	Nut
9	75-0205-9	75-0205-9	Cotter Pin
10	75-0205-10	75-0205-10	Hub Cap
11	75-0205-11	75-0205-11	Lug Nut
12	75-0207-12	75-0205-12	Stud Bolt
13	75-0207-1	75-0205-1	Hub Only w/Races & Studs
14	30-0008	30-0008	Nipple 1/8" NPT
15	30-0009	30-0009	Coupler 1/8" NPT
16	30-0006	30-0006	Zerk 1/8" NPTx90 Degrees
17	901-3860-4	901-3860-4	Locking Collar
18	881-5013-5.5	881-5013-5.5	HHCS 1/2x5-1/2", Grade 8
19	814-5013-Z	814-5013-Z	Locknut 1/2" Center
20	NA	901-3863	Tandem Beam w/Spindles Only
	NA	901-3890	Tandem Beam w/Hubs Complete
	901-3861	NA	Tandem Beam w/Spindles Only-Prior to Serial #SV083954527
	901-3891	NA	Tandem Beam w/Hubs Complete-Prior to Serial #SV083954527
	901-3861-R	NA	Right Beam Offset Pivot Less Hubs-Serial #SV083954527 & Later
	901-3861-L	NA	Left Beam Offset Pivot Less Hubs-Serial #SV083954527 & Later
20	901-3898	NA	Right Beam Offset Pivot W/Hubs-Serial #SV083954527 & Later
	901-3899	NA	Left Beam Offset Pivot W/Hubs-Serial #SV083954527 & Later
21	75-0107	75-0104	Spindle Only
22	Not Available	901-3828	Single Axle w/Spindles (2636 Only)
	Not Available	901-3892	Single Axle W/Hubs Complete (2636 Only)
23	901-3860-HD	901-3860-HD	Tandem Axle Assembly Only
24	75-0253	75-0253	Wheel Rim, W11Cx16.1 (14Lx16.1 Tire)
	53-1653	53-1653	14Lx16.1 Tire/Wheel Assembly
	75-0262-HD	75-0262-HD	Wheel Rim, W14Cx16.1 (16.5Lx16.1 Tire)
	53-3862	53-3862	16.5Lx16.1 Tire/Wheel Assembly
	75-0268-HD	75-0268-HD	Wheel Rim, 22.5 x 8.25 (11R x22.5 Used Tire)
	53-2768-H	53-2768-H	Used 11R22.5 Tire/Wheel Assembly
	75-0260-HD	*75-0260-HD	Wheel Rim, 22.5 x 13.5 (425/65/R22.5 Used Tire)
	53-2860-HD	*53-2860-HD	Used 425/65R22.5 Tire/Wheel Assembly
	75-0263-HD	*75-0263-HD	Wheel Rim, W16C x 16.1 (19L x 16.1 Flotation Tire)
	53-3763	*53-3763	19Lx16.1 Tire/Wheel Assembly

*Available with Optional O-Beam Package #SV-Hub-8000 (3245 Only)

*Single Axle (2636)

V-MAX HIGHWAY LIGHTING

KEY	PART NO.	DESCRIPTION	QTY
1	56-0030	Dual Light LH w/4-Plug	1
1a	56-0030-TR	Truck Mount Dual Light w/4-Plug	1
1/1a	56-0034	Adapter Harness 3-Plug to 4-Plug (Needed in addition to light for Serial #'s Prior to SV063245328) with 3-Plug Lights	2
2	56-0031	Dual Light RH w/4-Plug	1
2a	56-0031-TR	Truck Mount Dual Light w/4-Plug	1
2/2a	56-0034	Adapter Harness 3-Plug to 4-Plug (Needed in addition to light for Serial #'s Prior to SV063245328) with 3-Plug Lights	2
3	56-0003	Ag Light Harness W/Bullet Terminals (Prior to Serial #SV063245328)	1
	56-0032	Ag Light Harness W/Module (Serial #SV063245328 thru SV113954441)	
4	56-0004	#1232 4-Way Socket 4-Pin	1
5	56-0005	Coil Cable Assy.	1
5a	56-0005-2	7-Contact Plug Only	1
5b	56-0005-1	4-Hole Plug (End Only)	1
6	56-0008	Harness Frame Clip	3
7	56-0009	Store-A-Way Plug Holder	1
8	65-0006-5	Nylon Tie Straps	AR
9	925-3876	L.H. Light Mount Bracket	1
10	925-3877	R.H. Light Mount Bracket	1
11	56-0001-3	Bezel Blank, Black (Fit Inside Housing)	1
	56-0030-3	Bezel Blank, Black (Fit Over Housing)	1
12A	56-0001-5	#1156 Single Filament Bulb	1
12B	56-0001-4	#1157 Dual Filament Bulb	1
13	56-0001-2	Red Lens (Fit Inside Housing)	1
	56-0030-2	Red Lens (Fit Over Housing)	1
14	56-0001-1	Amber Lens (Fit Inside Housing)	1
	56-0030-1	Amber Lens (Fit Over Housing)	1
15	46-0001-62	Caution Tail Light Decal	1
16	56-0028	Tail Light Converter (Truck Mount Only)	1
17	56-0005-4	7-WAY PLUG W/SPRING MALE	1
18	56-0093	2636 LED LIGHT CORD WITH 7-PIN AG PLUG & 6 PIN CONNECTOR	1
	56-0094	3245 LED LIGHT CORD WITH 7-PIN AG PLUG & 6 PIN CONNECTOR	1
	56-0095	3954 LED LIGHT CORD WITH 7-PIN AG PLUG & 6 PIN CONNECTOR	1
19	56-0032-1	AG MODULE W/CONNECTORS	1
	56-0084	AG MODULE W/CONNECTORS (LED LIGHT HARNESS)	1
20	925-0015-1	V-MAX LH LED LIGHT MOUNT BRACKET	1
21	925-0014-1	V-MAX RH LED LIGHT MOUNT BRACKET	1
22	56-0092	4" ROUND GROMMET	4
23	55-0090	4" RED STOP/TAIL/TURN 12 LED LAMP	2
24	55-0091	4" AMBER TURN/WARNING 12 LED LAMP	2
25	56-0083	LED LIGHT Y-HARNESS LESS MODULE WITH PLUGS	1

OPTIONAL THIRD AUGER

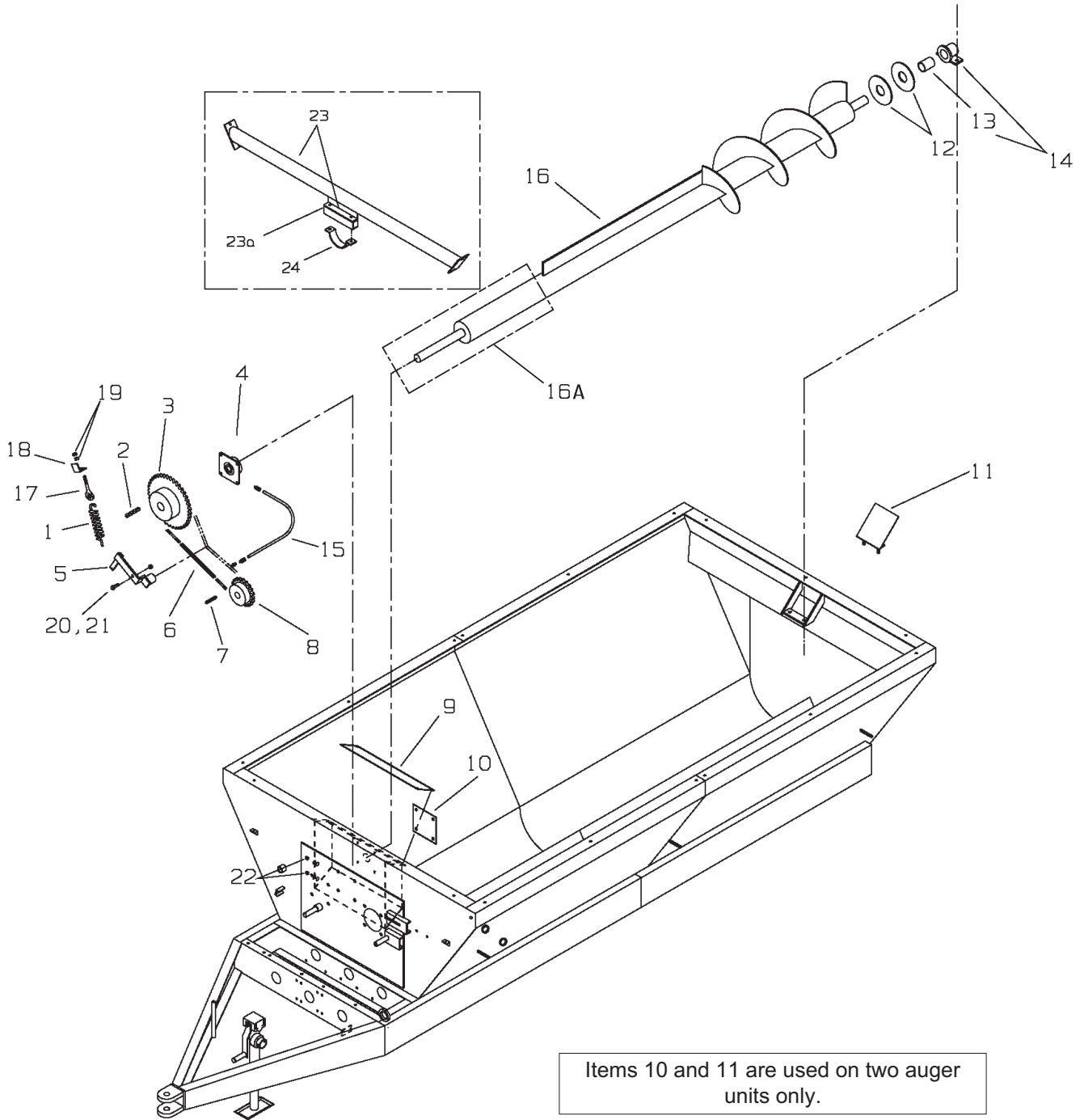

OPTIONAL THIRD AUGER

KEY	PART NO.	DESCRIPTION
1	929-3601	Extension Spring
2	35-0008	1/2"x1/2"x2" Square Key
3	910-0050	80B 26 2"B, 1/2" Keyway
4	14-0031	Bearing, 4-Bolt Flange, 2" B
5	925-3866	Chain Tightener Bracket Wldmt.
6	911-0033	#80-36 Roller Chain w/Conn.
7	35-0026	3/8"x3/8"x1-3/4" Square Key
8	910-0005	80B12, 1-1/2"B, 3/8" KWY
9	925-3861	Oil Bath Cover
10	925-3860	Bearing Hole Cover (2-Auger)
11	925-3863	3rd Auger Rear Support Cover (2-Auger)
12	933-3606	Bronze Washer
13	13-0023	Aluminum Bronze Bushing (Prior to 08 Models)
	913-3809	GSM Nylon Bushing (08 Models and Later)
14	925-3865	3rd Auger Rear Shaft Support Sleeve w/Bushing
15	933-3630	Copper Tube Grease Line 13" (includes zerk, fittings)
16	926-3819	Third Auger Assembly, 2636
	926-3820	Third Auger Assembly, 3245
	926-3821	Third Auger Assembly, 3954
16A	926-3810-9	Front Auger Shaft w/Sleeves
17	933-3804	Eyebolt, Full Thread
18	925-3825	Tightener Angle Clip
19	813-3118-Z	5/16-18 Nut Zinc
20	851-6311-2Z	5/8"-11x2" Gr. 5 Machine Bolt
21	814-6311-Z	5/8"-11 Center Lock Nut
22	955-3809	3/8" Square Head Steel Pipe Plug
23	901-3862	3rd Auger Front Support Assembly Models 3954 Only
23A	901-3862-1	Spacer Tube Models 3954 Only
24	901-3832-2	3rd Auger U Support Bracket Models 3954 Only

OPTIONAL OIL-KIT

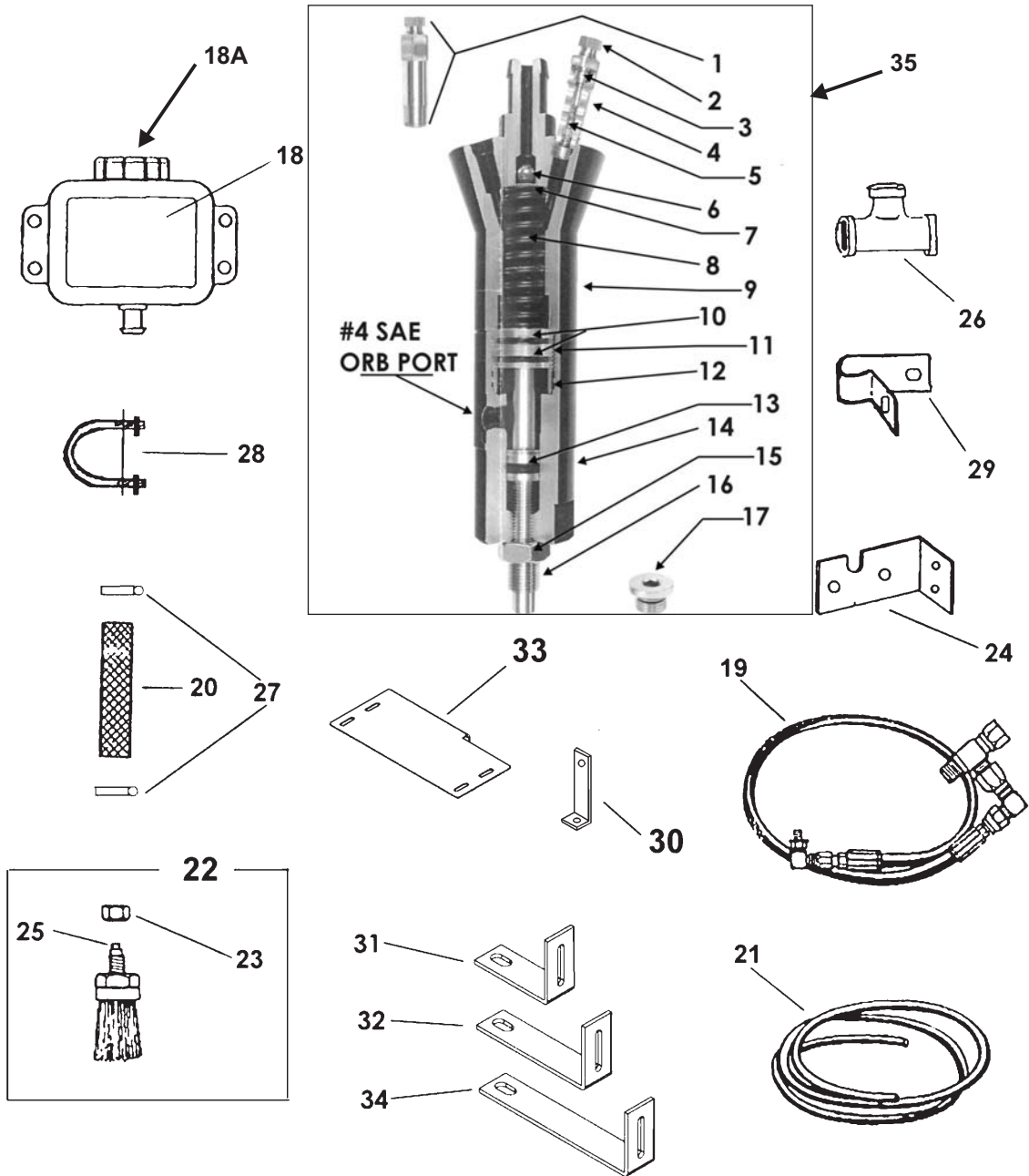

OPTIONAL OIL-KIT

KEY	PART NO.	DESCRIPTION
1	952-0001-1-33	Holder, Manifold Valve Assembly
2	952-0001-1-27	Sleeve Nut Brass
3	952-0001-1-28	5/32 Brass Ferrule
4	952-0001-1-13	Holder, Manifold Valve
5	952-0001-1-9	One Way Valve (Schrader Valve)
6	952-0001-1-11	Bearing, 7/16" Stainless
7	952-0001-1-10	Screen Flat Oiler .906 Dia
8	952-0001-1-5	Spring, Oiler
9	952-0001-1-1	Oiler Body 8 Port Black
10	952-0001-1-8	O Ring, Oiler Piston 2-022 90 Dur
11	952-0001-1-4	Piston, 2 Groove Alum, Short
12	952-0001-1-6	Washer, Rubber Lube Minder
13	952-0001-1-7	O Ring, Adj End Cap Plunger
14	952-0001-1-2	Adj End Cap Oil Black
15	952-0001-1-16	1/2-20 Jam Nut
16	952-0001-1-3	Plunger, Brass Adj End Cap
17	952-0001-1-32	1/8" Hex Head Pipe Plug
18	952-0001-1-18	Reservoir Two Quart Tank
18A	952-0001-1-35	Tank Cap Only
19	952-0001-1-19	Hydraulic Hose Assembly Meyer Mfg.
20	952-0001-1-20	Tubing 5/8" ID Clear Polybraid
21	952-0001-1-21	Tubing 5/32" Nylon (Feet)
22	952-0001-1-25	Brush Assembly No 5/32 Insert
23	813-5020-Z	1/2-20 Plated Nut
24	952-0001-1-17	Bracket Oiler Mtg Pump
25	952-0001-1-14	5/32 Push In Insert (Nycoil)
26	955-3803	BM Pipe Tee 3/8 x 3/8 x 3/8
27	952-0001-1-30	1" Hose Clamp
28	952-0001-1-31	U-Bolt Assembly #13
29	08-0050	5/16" Closed "J" Clip
30	952-0001-2	#80 Brush Holder
31	952-0001-3	Left #120 Auger Chain Brush Holder
32	952-0001-4	Right #120 Auger Chain Brush Holder
33	952-0001-5	Oiler Tank Mount Plate
34	952-0001-6	#80 Center Shaft Chain Brush Holder
35	952-0001-1-36	Oiler Body Pump Assy Complete

918-0212 PTO DRIVE SHAFT ASSEMBLY
(PRIOR TO SERIAL #SV083954451)
918-0312 PTO DRIVE SHAFT ASSEMBLY
(SERIAL #SV083954451 & LATER)
540 RPM 1-3/8 – 6 SPLINE YOKE
WWE2480 (80 DEGREE C.V.)

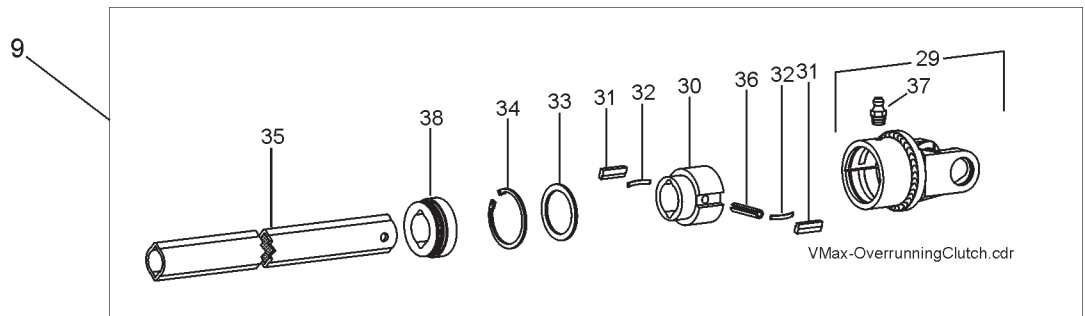
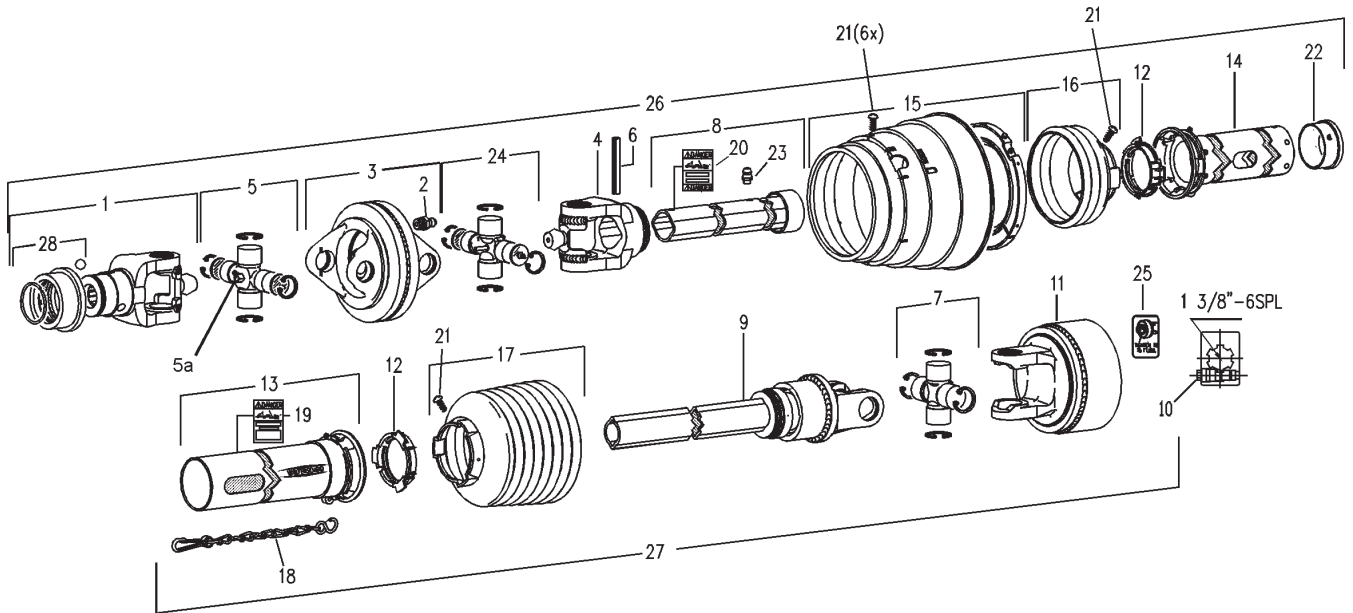

918-0212 PTO DRIVE SHAFT ASSEMBLY
 (PRIOR TO SERIAL #SV083954451)
918-0312 PTO DRIVE SHAFT ASSEMBLY
 (SERIAL #SV083954451 & LATER)
 540 RPM 1-3/8 – 6 SPLINE YOKE
 WWE2480 (80 DEGREE C.V.)

KEY	MEYER PART NO.	DESCRIPTION
1	918-0212-1-1	Yoke 1-3/8"-6 Splined Assembly
2	918-0208-1-2	Grease Zerk in item 3
3	918-0208-1-3	Double Yoke
4	918-0208-1-4	Inboard Yoke
5	918-0208-1-5	Cross and Bearing Kit
5a	918-0208-1-5-1	M8x1 67.5* Zerk in Cross & Bearing
6	918-0208-1-6	Spring Pin 10 x 80
7	918-0208-2-1	Cross and Bearing Kit
8	918-0208-1-14	Profile and Sleeve Wa
9	918-0208-2-2	Overrunning Clutch & 1bGA Profile Assy.
10	918-0208-2-3-1	Clamping Cone Bolt (Included in Item 11)
11	918-0212-2-1	Cut Out Clutch 1900NM (Prior to Serial #SV083954451)
	918-0312-1-1	Cut Out Clutch 1900NM (Serial #SV083954451 & Later)
12	918-0208-2-4	Bearing Ring SC25
13	918-0208-2-5	Outer Shield Tube OVL
14	918-0208-1-7	Inner shield Tube Round
15	918-0208-1-8	CV Cone & Bearing Assy.
16	918-0208-1-9	Shield Cone 3 Rib
17	918-0208-2-6	Shield Cone 8 Rib
18	918-0208-2-7	Safety Chain
19	918-0208-2-8	Decal Out-In Item 13
20	918-0208-1-10	Decal In-In Item 8
21	918-0208-2-9	Screw-In Item 15,16 & 17
22	918-0208-1-11	Support Bearing
23	918-0208-1-12	Zerk-In Item 8
24	918-0208-1-13	Cross and Bearing Kit
25	918-0208-2-10	Decal-K64
26	918-0212-1	1-3/8-6 Spline Tractor Half Assembly
27	918-0212-2	540 RPM Implement Half Assy (Prior to Serial # SV083954451)
	918-0312-1	540 RPM Implement Half Assy (Serial # SV083954451 & Later)
28	918-0208-1-1-1	AS-Lock Kit For Item 1 (Inc. Ring, Collar & Balls)
29	918-0208-2-2-2	Over-running Clutch Housing
30	918-0208-2-2-3	Over-running Clutch Hub
31	18-0119-1-1-2	Over-running Clutch Key
32	18-0119-1-1-1	Over-running Clutch Leaf Spring
33	918-0308-2-1-3	Over-running Clutch Supporting Ring
34	18-0119-1-1-6	Over-running Clutch Retaining Ring
35	918-0208-2-2-1	Profile Tube - 1bGA
36	918-0308-2-1-12	Spring Pin, 10 x 55
37	918-0208-1-2	Grease Zerk
38	918-0208-2-2-4	Bearing Ring

540 RPM 1-3/8 – 6 SPLINE YOKE
WWE2480 (80 DEGREE C.V.)
(PRIOR TO SERIAL #SV083954451)

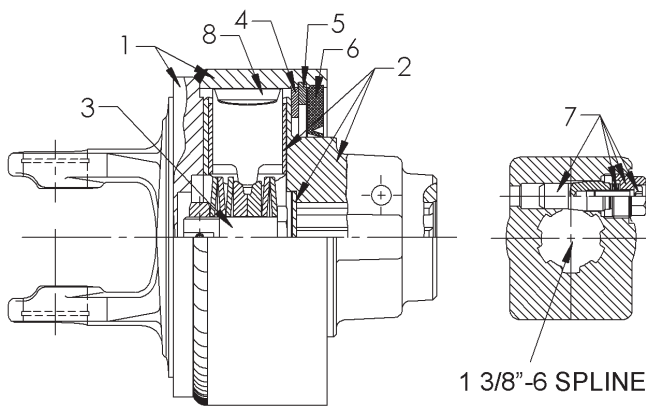

KEY	MEYER PART NO.	DESCRIPTION
1	918-0208-2-3-2	Housing
2	918-0208-2-3-3	Hub
3	918-0208-2-3-4	Spring Pack 1900NM
4	918-0208-2-3-5	Washer
5	918-0208-2-3-6	Retaining Ring
6	918-0208-2-3-7	Sealing Ring
7	918-0208-2-3-1	Clamp Cone Assembly
8	918-0208-2-3-8	Cam
NS	918-0208-2-3-9	Bushing-In Item #2
NS	918-0208-2-3-11	Shim Kit

540 RPM 1-3/8 – 6 SPLINE YOKE
WWE2480 (80 DEGREE C.V.)
(SERIAL #SV083954451 & LATER)

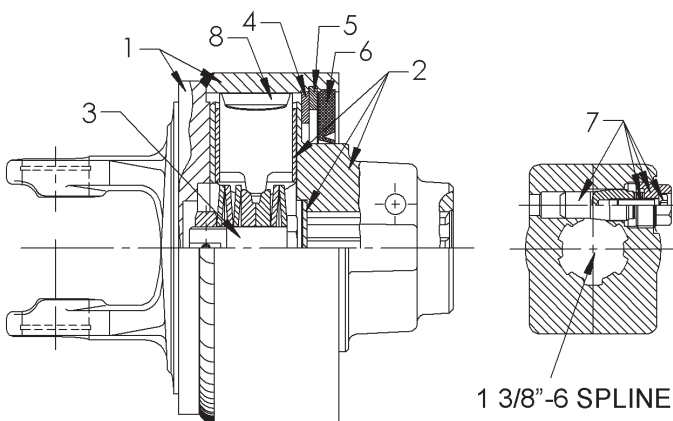

KEY	MEYER PART NO.	DESCRIPTION
1	918-0308-2-2-1	Housing
2	918-0308-2-2-2	Hub
3	918-0312-1-1-1	Spring Pack 1900NM
4	918-0208-2-3-5	Washer
5	918-0208-2-3-6	Retaining Ring
6	918-0208-2-3-7	Sealing Ring
7	918-0208-2-3-1	Clamp Cone Assembly
8	918-0308-2-2-4	Cam
NS	918-0312-1-1-2	Bushing-In Item #2
NS	918-0208-2-3-11	Shim Kit

1000 RPM ADD-ON KIT SVS-RPM-KIT

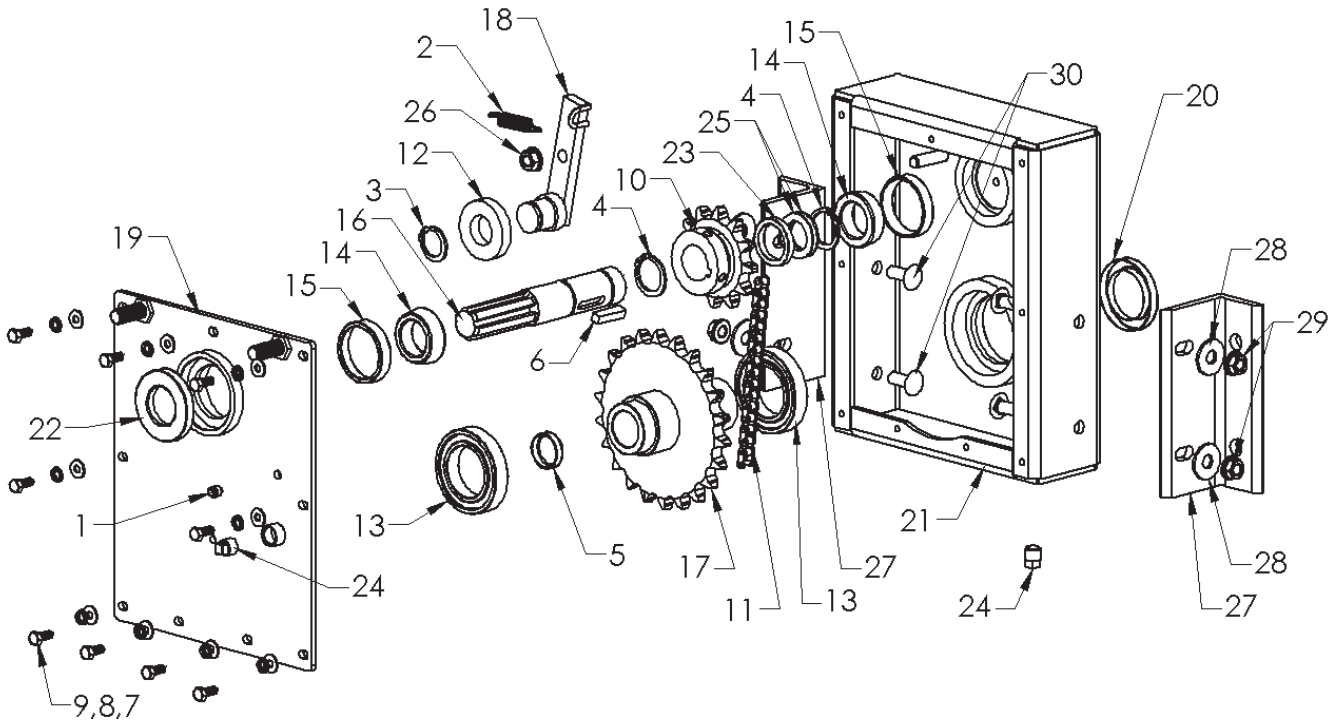

KEY	PART NO.	DESCRIPTION	QTY.
1	19-0002-17	Vent Plug	1
2	29-0015	Tightener Spring	1
3	33-0012	Retaining Ring 1-1/4"	1
4	33-0021	Retaining Ring 1-1/2"	2
5	33-0039	Expansion Plug	1
6	935-0003	3/8X3/8X1-1/2" Key Rd Ends	1
7	805-0031-Z	5/16" Flat Washers	9
8	806-0031-Z	5/16" Internal Tooth Lockwashers	9
9	851-3118-.75Z	5/16-18x3/4" Gr. 5 Machine Bolt	9
10	910-0005	80B12 1-1/2" Bore Sprocket	1
11	911-0045-HD	#80 Heavy Duty-30 Pitch Roller Chain	1
12	912-0010	Chain Tightener Roller	1
13	914-3809	Output Quill Bearing	2
14	914-3816	Input Shaft Bearing	2
15	914-3817	Input Shaft Bearing Race	2
16	923-3834	Splined Input Shaft	1
17	923-3835	Output Quill	1
18	925-3890-1	Chain Tightener Weldment Less Roller	1
19	925-3891-1	Front Cover Plate Welded Assembly	1
20	925-3892-10	2-1/8" Seal	1
21	925-3892-1	Main Tube Weldment	1
22	925-3892-9	1-1/2" Seal	1
23	933-3812	Input Shaft Spacer	1
24	955-3809	3/8" NPT Square Plug	2
25	808-1.5-2.25-14	1-1/2IDx2-1/4ODx14 Ga. Machine Bushing	AR
26	814-5013-Z	1/2-13 Center Locknut	1
27	925-3892-7	RPM Tube Mount Angles	2
28	805-0050-Z	1/2" Flat Washer	4
29	810-5013-Z	1/2" Spin Locknut	4
NS	48-0044	85W140 Lube Oil	3.5 Qts
NS	46-0001-23	Oil Decal	1
NS	46-2636-11	1000 RPM Decal	1

918-0209 PTO DRIVE SHAFT ASSEMBLY
 1000 RPM 1-3/8" 21 SPLINE (STANDARD)

918-0211 PTO DRIVE SHAFT
 1000 RPM 1-3/4" 20 SPLINE (OPTIONAL)
 WWE2480 (80 DEGREE C.V.)

PRIOR TO 08 SERIAL NUMBERS WITH 1000 RPM ADD-ON KIT

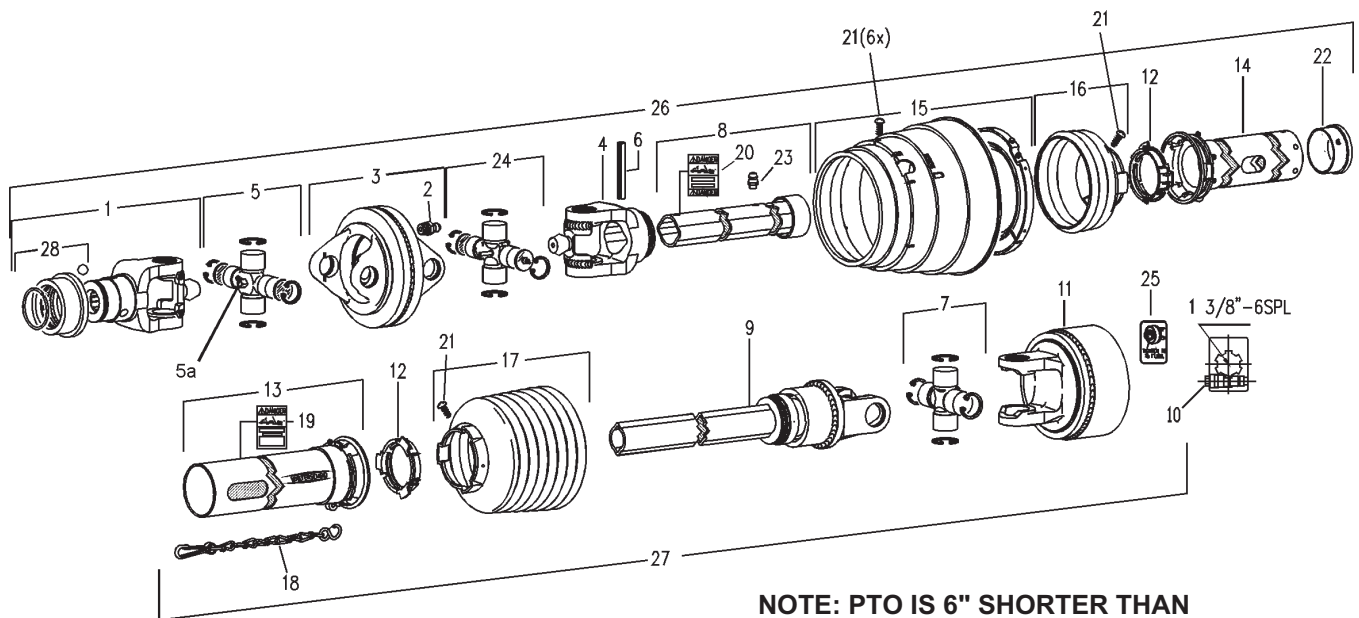

**NOTE: PTO IS 6" SHORTER THAN
 STANDARD 540 OR 1000 RPM PTO**

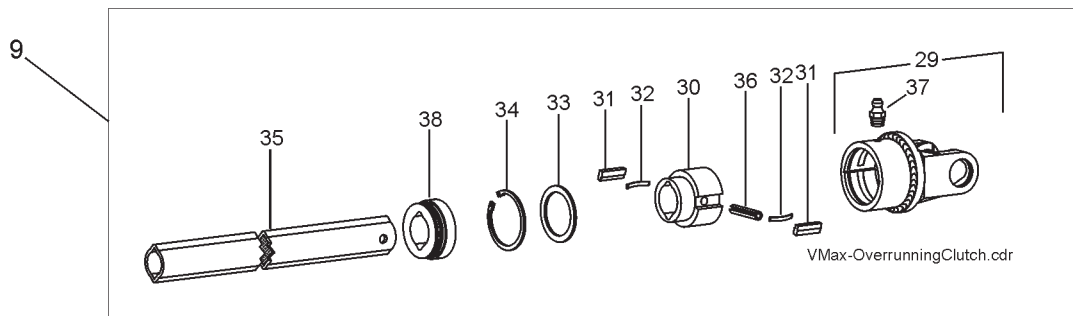

918-0209 PTO DRIVE SHAFT ASSEMBLY
1000 RPM 1-3/8" 21 SPLINE (STANDARD)

918-0211 PTO DRIVE SHAFT
1000 RPM 1-3/4" 20 SPLINE (OPTIONAL)
WWE2480 (80 DEGREE C.V.)

PRIOR TO 08 SERIAL NUMBERS WITH 1000 RPM ADD-ON KIT

KEY	MEYER PART NO.	DESCRIPTION
1	918-0208-1-1	Yoke 1-3/8"-21 Splined Assembly-Standard
	918-0210-1-1	Yoke 1-3/4"-20 Splined Assembly-Optional
2	918-0208-1-2	Grease Zerk in item 3
3	918-0208-1-3	Double Yoke
4	918-0208-1-4	Inboard Yoke
5	918-0208-1-5	Cross and Bearing Kit
5a	918-0208-1-5-1	M8x1 67.5° Zerk In Cross Brg
6	918-0208-1-6	Spring Pin 10 x 80
7	918-0208-2-1	Cross and Bearing Kit
8	918-0209-1-2	Profile and Sleeve Welded As. 6" Shorter
9	918-0209-2-2	Overrunning Clutch & 1bGA Profile Assy. 6" Shorter
10	918-0208-2-3-1	Clamping Cone Bolt (Included in Item 11)
11	918-0208-2-3	Cut Out Clutch 2100NM
12	918-0208-2-4	Bearing Ring SC25
13	918-0209-2-1	Outer Shield Tube OVL 6" Shorter
14	918-0209-1-1	Inner shield Tube Round 6" Shorter
15	918-0208-1-8	CV Cone & Bearing Assy.
16	918-0208-1-9	Shield Cone 3 Rib
17	918-0208-2-6	Shield Cone 8 Rib
18	918-0208-2-7	Safety Chain
19	918-0208-2-8	Decal Out-In Item 13
20	918-0208-1-10	Decal In-In Item 8
21	918-0208-2-9	Screw-In Item 15,16 & 17
22	918-0208-1-11	Support Bearing
23	918-0208-1-12	Zerk-In Item 8
24	918-0208-1-13	Cross and Bearing Kit
25	918-0208-2-10	Decal-K64
26	918-0209-1	1-3/8-21 (Std) Spline Tractor 1/2 Assembly-6" Shorter
	918-0211-1	1-3/4-20 (Optional) Spline Tractor 1/2 Assembly-6" Shorter
27	918-0209-2	1000 RPM Cutout Clutch Implement 1/2 Assy. 6" Shorter
28	918-0208-1-1-1	AS-Lock Kit For Item 1 (Inc. Ring, Collar & Balls)
	918-0210-1-1-1	AS-Lock Kit For Item 1 (Inc. Ring, Collar & Balls) 1-3/4 20 Spline
29	918-0208-2-2-2	Over-running Clutch Housing
30	918-0208-2-2-3	Over-running Clutch Hub
31	18-0119-1-1-2	Over-running Clutch Key
32	18-0119-1-1-1	Over-running Clutch Leaf Spring
33	918-0308-2-1-3	Over-running Clutch Supporting Ring
34	18-0119-1-1-6	Over-running Clutch Retaining Ring
35	918-0209-2-2-1	Profile Tube - 1bGA 6" Shorter
36	918-0308-2-1-12	Spring Pin, 10 x 55
37	918-0208-1-2	Grease Zerk
38	918-0208-2-2-4	Bearing Ring

918-0209 PTO DRIVE SHAFT ASSEMBLY
 1000 RPM 1-3/8" 21 SPLINE (STANDARD)

918-0211 PTO DRIVE SHAFT
 1000 RPM 1-3/4" 20 SPLINE (OPTIONAL)
 WWE2480 (80 DEGREE C.V.)

CUTOUT CLUTCH

PRIOR TO 08 SERIAL NUMBERS WITH 1000 RPM ADD-ON KIT

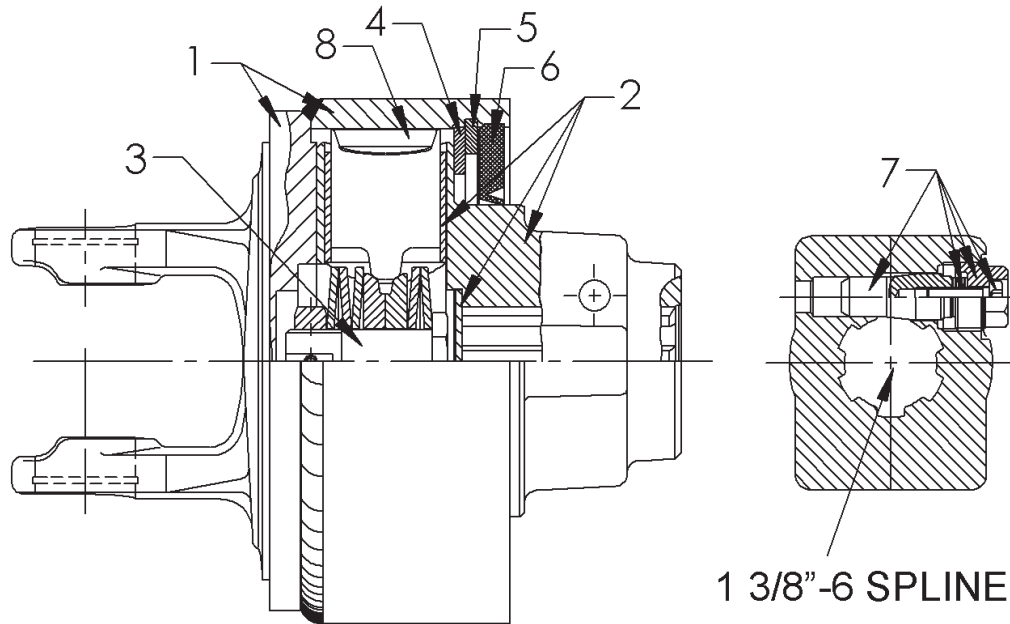

KEY	MEYER PART NO.	DESCRIPTION
1	918-0208-2-3-2	Housing
2	918-0208-2-3-3	Hub
3	918-0208-2-3-10	Spring Pack 2100NM
4	918-0208-2-3-5	Washer
5	918-0208-2-3-6	Retaining Ring
6	918-0208-2-3-7	Sealing Ring
7	918-0208-2-3-1	Clamp Cone Assembly
8	918-0208-2-3-8	Cam
NS	918-0208-2-3-9	Bushing-In Item #2
NS	918-0208-2-3-11	Shim Kit

This Page Intentionally Blank.

918-0309 PTO DRIVE SHAFT ASSEMBLY
 1000 RPM-1-3/8", 21 SPLINE SP (STANDARD)

918-0311 PTO DRIVE SHAFT ASSEMBLY
 1000 RPM 1-3/4", 20 SPLINE (OPTIONAL)
 WWE2480 (80 DEGREE C.V.)

SERIAL NUMBERS 08 AND LATER WITH 1000 RPM ADD-ON KIT

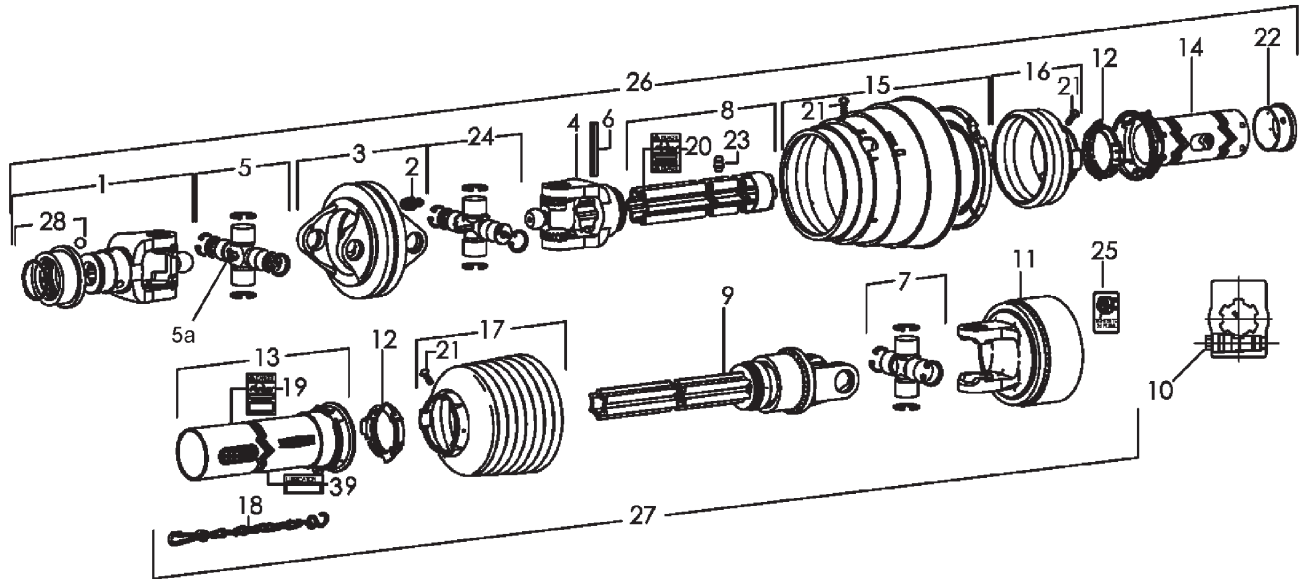

NOTE: PTO IS 4" SHORTER (1-3/4x20) 6" SHORTER (1-3/8x21) THAN STANDARD 540 OR 1000 RPM PTO

SEE PAGE 68 FOR CUTOUT CLUTCH

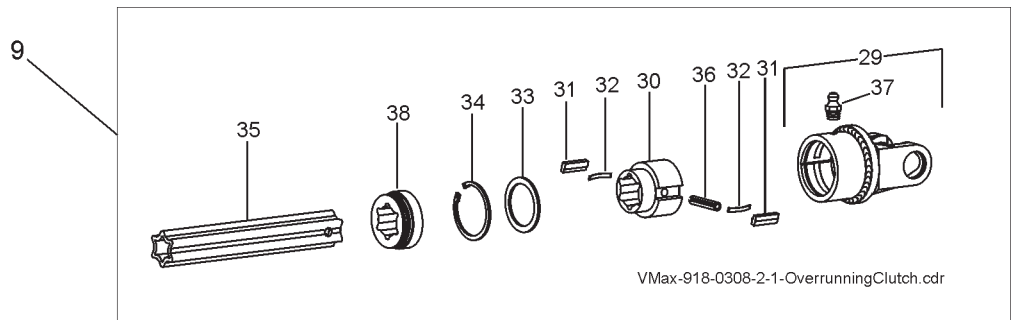

VMax-918-0308-2-1-OverrunningClutch.cdr

918-0309 PTO DRIVE SHAFT ASSEMBLY
1000 RPM-1-3/8", 21 SPLINE SP (STANDARD)

918-0311 PTO DRIVE SHAFT ASSEMBLY
1000 RPM 1-3/4", 20 SPLINE (OPTIONAL)
WWE2480 (80 DEGREE C.V.)

SERIAL NUMBERS 08 AND LATER WITH 1000 RPM ADD-ON KIT

KEY	MEYER PART NO.	DESCRIPTION
1	918-0208-1-1	Yoke 1-3/8"-21 Splined Assembly-Standard
	918-0210-1-1	Yoke 1-3/4"-20 Splined Assembly-Optional
2	918-0208-1-2	Grease Zerk in item 3
3	918-0208-1-3	Double Yoke
4	918-0308-1-1	Inboard Yoke
5	918-0208-1-5	Cross and Bearing Kit
5a	918-0208-1-5-1	M8x1 67.5° Zerk In Cross Brg
6	918-0208-1-6	Spring Pin 10 x 80
7	918-0208-2-1	Cross and Bearing Kit
8	918-0309-1-2	Profile and Sleeve Welded Assy. 6" Shorter
	918-0311-1-2	Profile and Sleeve Welded Assy. 4" Shorter
9	918-0309-2-2	Overrunning Clutch & S4LGA Profile Assy. 6" Shorter
	918-0311-2-2	Overrunning Clutch & S4LGA Profile Assy. 4" Shorter
10	918-0208-2-3-1	Clamping Cone Bolt (Included in Item 11)
11	918-0308-2-2	Cut Out Clutch 2200NM
12	918-0208-2-4	Bearing Ring SC25
13	918-0309-2-3	Outer Shield Tube OVL 6" Shorter
14	918-0309-1-1	Inner shield Tube Round 4" Shorter
15	918-0308-1-3	CV Cone & Bearing Assy.
16	918-0308-1-4	Shield Cone 3 Rib
17	918-0308-2-5	Shield Cone 8 Rib
18	918-0208-2-7	Safety Chain
19	918-0208-2-8	Decal Out-In Item 13
20	918-0208-1-10	Decal In-In Item 8
21	918-0208-2-9	Screw-In Item 15,16 & 17
22	918-0208-1-11	Support Bearing
23	918-0208-1-12	Zerk-In Item 8
24	918-0208-1-13	Cross and Bearing Kit
25	918-0208-2-10	Decal-K64

KEY	MEYER PART NO.	DESCRIPTION
26	918-0309-1	1-3/8-21 (Std) Spline Tractor 1/2 Assembly-6" Shorter -Star Profile
	918-0311-1	1-3/4-20 (Optional) Spline Tractor 1/2 Assembly-4" Shorter-Star Profile
27	918-0309-2-S	1000 RPM Cutout Clutch Implement 1/2 Assy. 6" Shorter-Star Profile, 1-3/8x21
	918-0309-2	1000 RPM Cutout Clutch Implement 1/2 Assy. 4" Shorter-Star Profile, 1-3/4x20
28	918-0208-1-1-1	AS-Lock Kit For Item 1 (Inc. Ring, Collar & Balls) 1-3/8 21 Spline
	918-0210-1-1-1	AS-Lock Kit For Item 1 (Inc. Ring, Collar & Balls) 1-3/4 20 Spline
29	918-0308-2-1-1-5	Over-running Clutch Housing
30	918-0308-2-1-10	Over-running Clutch Hub
31	18-0119-1-1-2	Over-running Clutch Key
32	18-0119-1-1-1	Over-running Clutch Leaf Spring
33	918-0308-2-1-3	Over-running Clutch Supporting Ring
34	18-0119-1-1-6	Over-running Clutch Retaining Ring
35	918-0309-2-1-8	Profile Tube - S4LGA 6" Shorter
	918-0311-2-1-8	Profile Tube - S4LGA 4" Shorter
36	918-0308-2-1-12	Spring Pin, 10 x 55
37	918-0208-1-2	Grease Zerk
38	918-0308-2-1-11	Bearing Ring
39	918-0308-2-6	Lubrication Decal

See page 68 for cutout clutch.

918-0309 PTO DRIVE SHAFT ASSEMBLY
 1000 RPM-1-3/8", 21 SPLINE SP (STANDARD)

918-0311 PTO DRIVE SHAFT ASSEMBLY
 1000 RPM 1-3/4", 20 SPLINE (OPTIONAL)

CUTOUT CLUTCH

SERIAL NUMBERS 08 AND LATER WITH 1000 RPM ADD-ON KIT

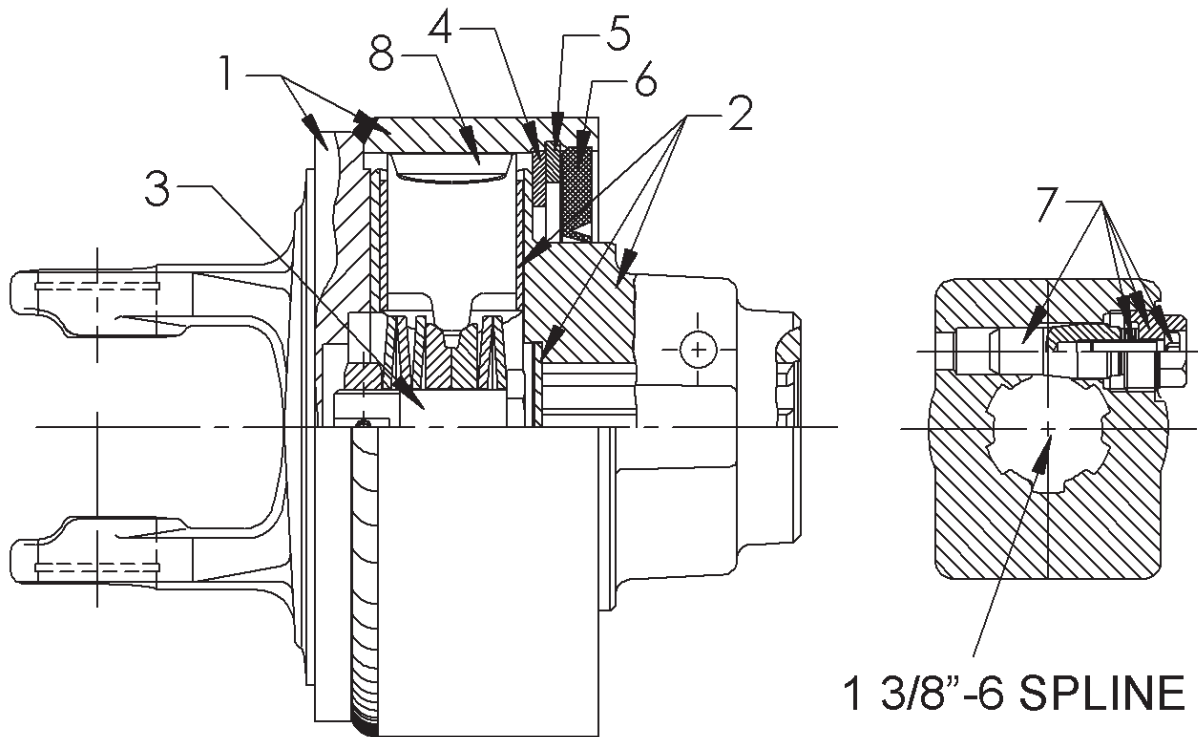

KEY	MEYER PART NO.	DESCRIPTION
1	918-0208-2-3-2	Housing
2	918-0208-2-3-3	Hub
3	918-0208-2-3-10	Spring Pack 2100NM
4	918-0208-2-3-5	Washer
5	918-0208-2-3-6	Retaining Ring
6	918-0208-2-3-7	Sealing Ring
7	918-0208-2-3-1	Clamp Cone Assembly
8	918-0208-2-3-8	Cam
NS	918-0208-2-3-9	Bushing-In Item #2
NS	918-0208-2-3-11	Cutout Clutch Shim Kit

See page 66 for PTO Drive Shaft Assembly.

This Page Intentionally Blank.

918-0308 PTO DRIVE SHAFT ASSEMBLY

1-3/8" 21 SPLINE S.P. (FACTORY BUILT 1000 RPM, NOT KIT EQUIPPED)
WWE2480 (80 DEGREE C.V.)

918-0310 PTO DRIVE SHAFT ASSEMBLY

1-3/4" 20 SPLINE S.P. (OPTIONAL)(FACTORY BUILT 1000 RPM, NOT KIT EQUIPPED)
WWE2480 (80 DEGREE C.V.)

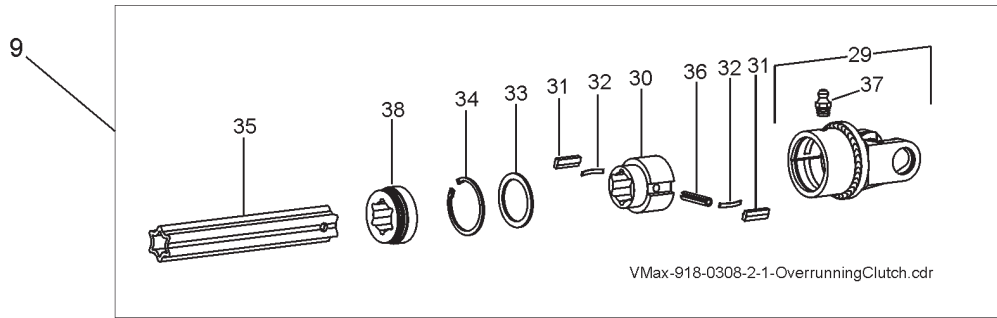
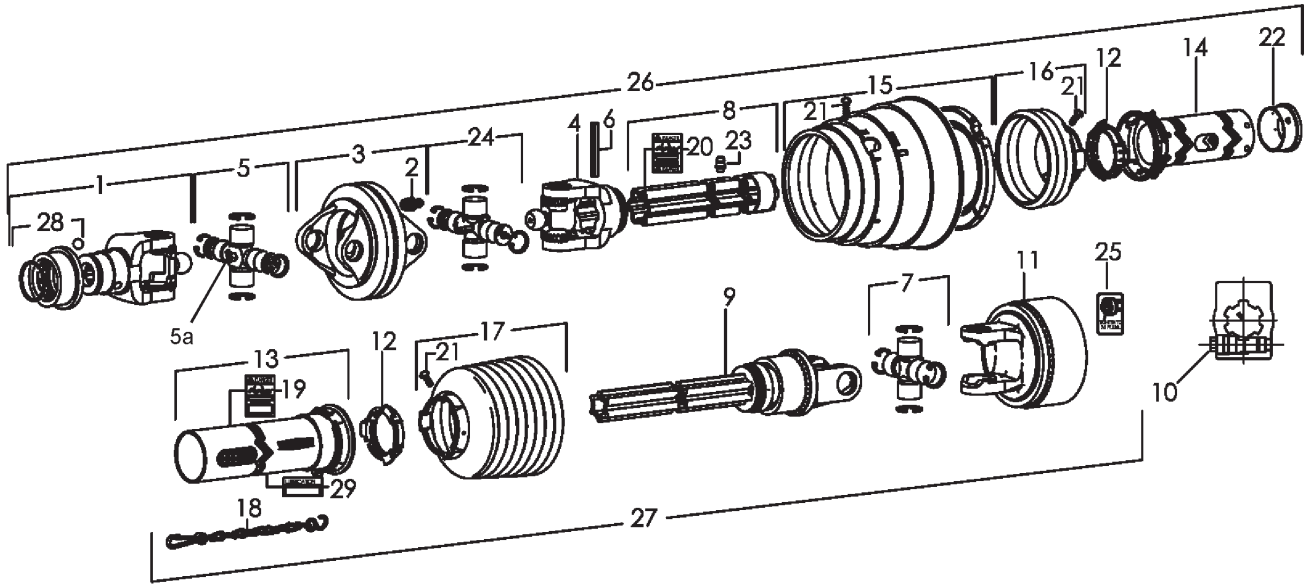

VMax-918-0308-2-1-OverrunningClutch.cdr

918-0308 PTO DRIVE SHAFT ASSEMBLY
1-3/8" 21 SPLINE S.P. (FACTORY BUILT 1000 RPM, NOT KIT EQUIPPED)
WWE2480 (80 DEGREE C.V.)

918-0310 PTO DRIVE SHAFT ASSEMBLY
1-3/4" 20 SPLINE S.P. (OPTIONAL)(FACTORY BUILT 1000 RPM, NOT KIT EQUIPPED)
WWE2480 (80 DEGREE C.V.)

KEY	PART NO.	DESCRIPTION
1	918-0208-1-1	Yoke 1-3/8"-21 Splined Assembly
2	918-0208-1-2	Grease Zerk in Item 3 & 9
3	918-0208-1-3	Double Yoke
4	918-0308-1-1	Inboard Yoke
5	918-0208-1-5	Cross and Bearing Kit
5a	918-0208-1-5-1	M8x1 67.5° Zerk In Cross Brg
6	918-0208-1-6	Spring Pin 10 x 80
7	918-0208-2-1	Cross and Bearing Kit
8	918-0308-1-2	Profile S5 and Sleeve Welded Assy.
9	918-0308-2-1	Overrunning Clutch & S4LGA Profile Assy.
10	918-0208-2-3-1	Clamp Cone Locking Pin
11	918-0308-2-2	Cut Out Clutch
12	918-0208-2-4	Bearing Ring SC25
13	918-0308-2-3	Outer Shield Tube OVL
14	918-0308-2-4	Inner Shield Tube Round
15	918-0308-1-3	CV Cone and Bearing Assy.
16	918-0308-1-4	Shield Cone 3-Rib
17	918-0308-2-5	Shield Cone 8-Rib
18	918-0208-2-7	Safety Chain
19	918-0208-2-8	Decal Outer-In Item 13
20	918-0208-1-10	Decal Inner-In Item 8
21	918-0208-2-9	Screw-In Item 15,16 & 17

KEY	PART NO.	DESCRIPTION
22	918-0208-1-11	Support Bearing
23	918-0208-1-12	Zerk-In Item 8
24	918-0208-1-13	Cross and Bearing Kit
25	918-0208-2-10	Decal-K64
26	918-0308-1	1-3/8-21 Spline Tractor Half Assy.
	918-0310-1	1-3/4-20 Spline Tractor Half Assy.
27	918-0308-2	1000 RPM Implement 1/2 Assy.
28	918-0208-1-1-1	Assembly Collar Kit (Inc. Ring, Collar & Balls)
29	918-0308-2-1-1-5	Over-running Clutch Housing
30	918-0308-2-1-10	Over-running Clutch Hub
31	18-0119-1-1-2	Over-running Clutch Key
32	18-0119-1-1-1	Over-running Clutch Leaf Spring
33	918-0308-2-1-3	Over-running Clutch Supporting Ring
34	18-0119-1-1-6	Over-running Clutch Retaining Ring
35	918-0308-2-1-8	Profile Tube - S4LGA
36	918-0308-2-1-12	Spring Pin, 10 x 55
37	918-0208-1-2	Grease Zerk
38	918-0308-2-1-11	Bearing Ring
39	918-0308-2-6	Lubrication Decal

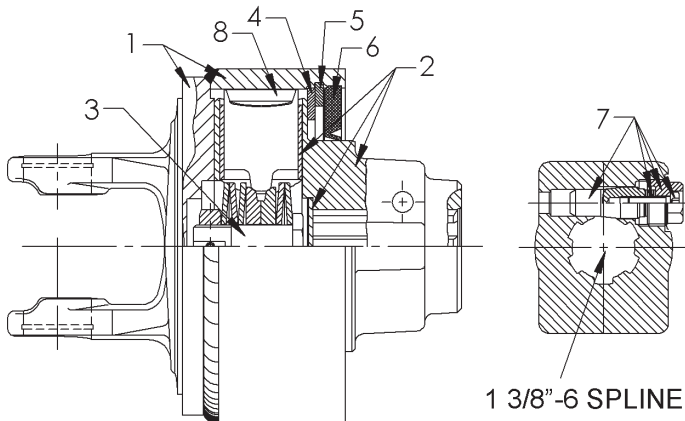

KEY	PART NO.	DESCRIPTION
1	918-0308-2-2-1	Housing
2	918-0308-2-2-2	Hub (Prior to serial #SI088720425)
	618-0003-2-1	Hub (Serial #SI088720426 & Later)
3	918-0308-2-2-3	Spring Pack
4	918-0208-2-3-5	Washer
5	918-0208-2-3-6	Retaining Ring
6	918-0208-2-3-7	Sealing Ring
7	918-0208-2-3-1	Clamp Cone Locking Pin
8	918-0308-2-2-4	Cam
NS	918-0208-2-3-9	Bushing-In Item #2
NS	918-0208-2-3-11	Shim Kit

#918-0150 VERTICAL DRIVELINE, TRUCK MOUNT MECHANICAL DRIVE

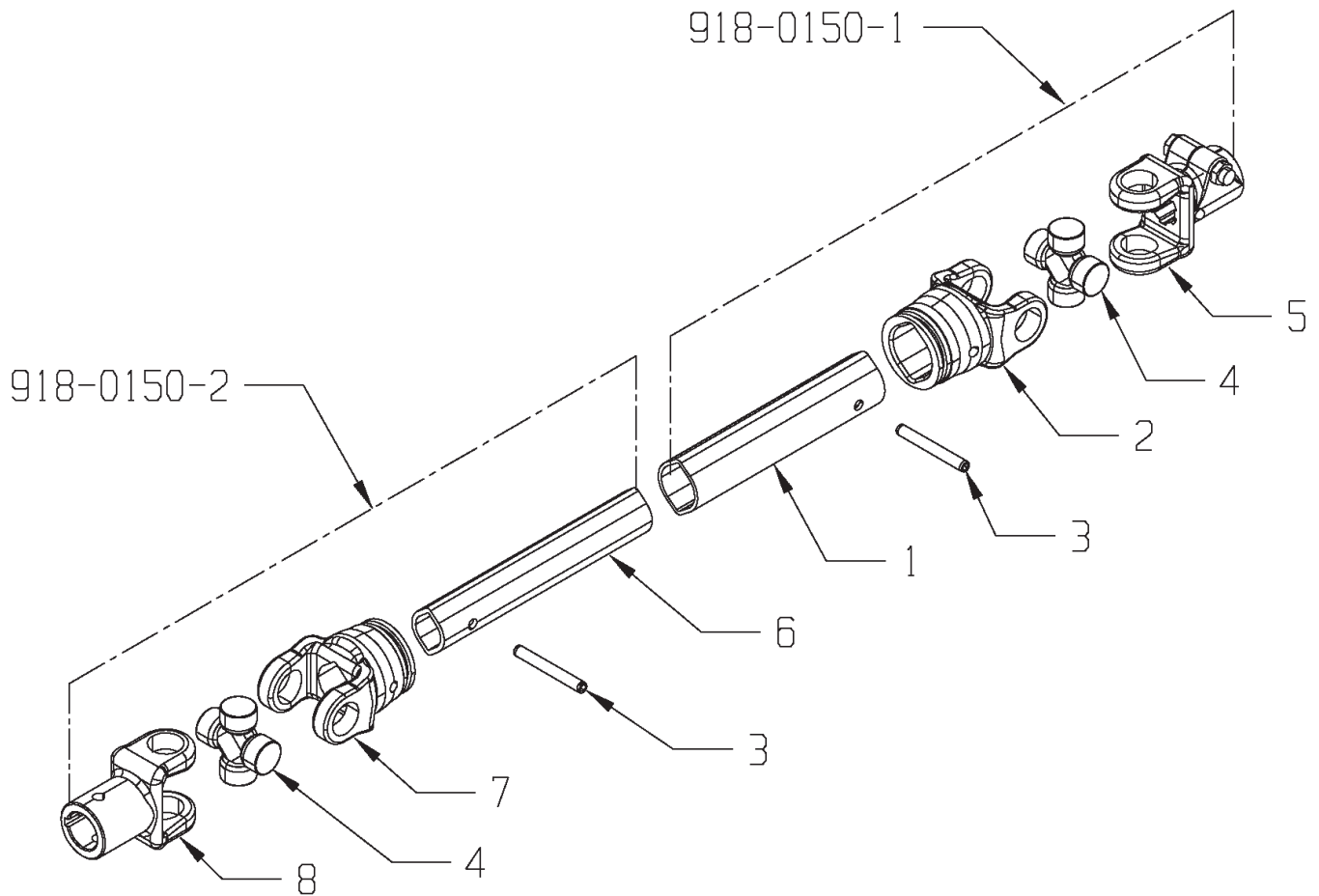

KEY	PART NO.	DESCRIPTION	QTY.
1	918-0150-1-1	18 Ga. Profile Tube	1
2	618-0001-2-2	Inboard Yoke 2a Lemon Profile	1
3	918-0208-1-6	Spring Pin 10 x 80	2
4	918-0208-2-1	Cross & Bearing Kit	2
5	918-0240-1-1	Clamp Yoke 2400 1-3/8 6 Spline AGKF	1
6	918-0150-2-1	Profile And Sleeve WA	1
7	918-0230-2-2-T	Hub Yoke w/Key 1-3/8" Bore, 5/16 Key	1
8	618-0001-1-2	Inboard Yoke 1b Lemon Profile	1

OPTIONAL TRUCK GEARBOX DRIVE PACKAGE #SV-GBD

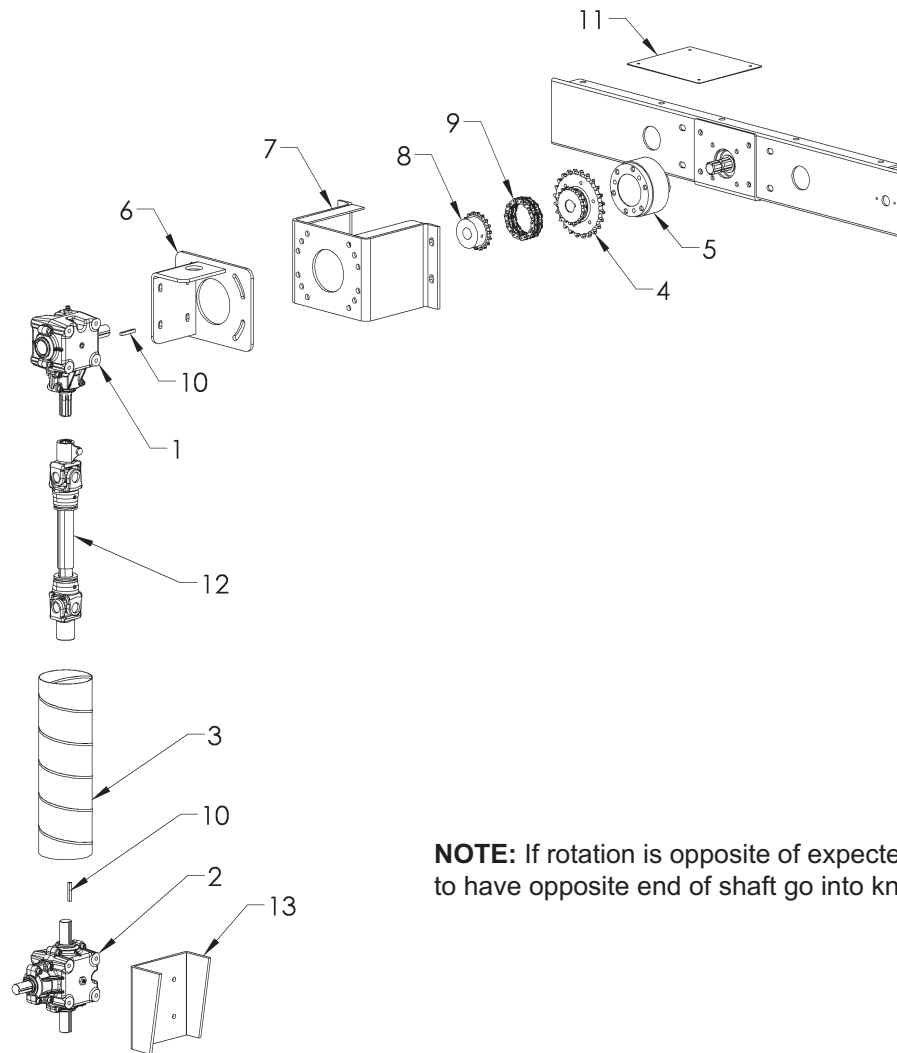

NOTE: If rotation is opposite of expected, flip gearbox to have opposite end of shaft go into knuckle.

KEY	PART NO.	DESCRIPTION	QTY.
1	19-0047	Mech Trk Mnt Upper Gearbox V-Max/VForce, 1:1 w/Syn Oil	1
2	19-0038-SYN	Gearbox 2:1 w/Syn Oil	1
3	49-0032	6" Hose	3.33'
4	910-0098	60B18/80B24 Sprocket w/Bolt Circle	1
5	918-0220-1	Walt Tk Mt Clutch w/Bolts & Washers, #X395028 RHEK64/2R	1
6	925-8003	Truck Upper Gearbox Bracket	1
7	925-8004	Truck Front Gearbox Bracket	1
8	937-0014-1	60B18 1-3/8" Bore Chain Coupler	1
9	937-0009-2	Coupler Chain #60-2R-17P-Q w/o Connector Link	1
	937-0009-3	Connector Link	1
10	935-0002	Key, 5/15x5/16x2-1/4" Hardened	2
11	925-8003-4	Truck Mech Drive Top Shield	1
12	918-0150	V-Max/VForce, GBD Vertical Driveline (see page 72)	1
13	MT-PTO-0888-511-03	Lower Gearbox Angled Bracket	1

MEYER SUPER SPREADER “TROUBLE SHOOTING”

	SYMPTOM	PROBLEM	SOLUTION
AUGERS	Augers shake or chatter	Stiff roller chains - dry Loose roller chains Worn sprockets/chains Dry auger trough	Lubricate roller chains Tighten roller chains Replace sprockets/chains Load auger trough w/manure
	Augers wobble/lift up & down	Worn auger shaft bushings Worn auger hold down nylon bearings	Replace auger shaft bushings Replace auger hold down nylon bearings
FLOW CONTROL GATE	Will not lift	No hydraulic supply Froze tight	Supply hydraulic power Thaw frozen build-up
	Will not close/seal	Lodged foreign object/dirty	Remove foreign object/clean
	Sticks/binds	Dirty/dry slide guides Worn slide guides Worn out slide guide poly-slick	Clean/lubricate slide guides Replace slide guides Replace slide guide poly-slick
GEAR BOXES	Clunking sounds	Gears/bearings wearing low level of liquid grease	Replace gears/bearings-fill with semi-fluid, EP lithium base, gear grease
	Excessive oil use	Worn out oil seals Dry manure & twine wrapping	Replace oil seals Clean & remove build-up at seal areas
	Gear damage	High speed/full load start-up Worn out gears	Slow start-up, fill with oil Replace gears
MATERIAL GUIDES	Poor spreading pattern	Material guides out of adjustment	Adjust according to manual specifications
	Dirty/build-up	Too slow spinner RPM's	Operate spreader at recommended 540 RPM
	Bending/breakage	Lodging foreign objects Multiple damaged paddles	Avoid loading foreign objects Replace paddles
PTO SHAFT	Whips/shakes	Over extended or bent PTO	Adjust tractor drawbar length (See Page 8) Straighten/replace PTO
	Vibrates up & down	Spreader center shaft bent	Replace center shaft
	Worn Universal Joints	Lack of lubrication/used	Lubricate joints daily replace joint

MEYER SUPER SPREADER “TROUBLE SHOOTING”

	SYMPTOM	PROBLEM	SOLUTION
ROLLER CHAINS AND SPROCKETS	Excessive chain wear	Lack of lubrication Out of alignment/loose	Lubricate/align/tighten
	Roller chain breakage	Loose roller chain Worn sprockets	Tighten roller chains Replace sprockets
	Sprocket teeth tipped over	Worn roller chain Bad roller bearings	Replace roller chain Replace bearings
SPINNERS (PADDLES/TEETH)	Spinners turn hard/squeak	Bad lower spinner bearings	Replace lower spinner bearings
	Shake at high RPM's (excessive vibration)	Spinner bent/out of balance Worn out lower spinner sleeve/shaft	Straighten/balance/replace spinner Replace lower spinner sleeve/shaft and re-weld.
	Excessive paddle damage	Too slow spinner RPM's	Operate spreader at recommended 540 RPM
		Lodging of manure	Adjust material guides Straighten/replace paddles/Keep sharpened
		Spreading foreign objects	Avoid loading foreign objects
TRIP PAN DOORS	Will not latch (close)	Dirty doors Loose Poly Slick	Clean doors Refasten/replace Poly Slick Straighten/replace doors
	Will not unlatch (open)	Bent doors Locked Frozen tight/rusted	Un-latch lever manually Thaw frozen build-up/oil shaft

This Page Intentionally Blank

MEYER EQUIPMENT WHEEL TORQUE

BOLT/STUD SIZE	SOCKET SIZE	PRESS FORMED WHEEL CENTER	BOLT TYPE	HEAVY DUTY WHEEL CENTER
1/2	3/4	80 ft lbs	Lug Bolt	85 ft lbs
9/16	7/8	80 ft lbs	Lug Bolt	120 ft lbs
5/8	15/16 1-1/16	100 ft lbs	Bevel or Flange Nut	160 ft lbs
3/4	1-1/8 / 1-1/2	NA	Flange Nut	378 ft lbs
22MM	32MM	NA	Flange Nut	450-500 ft lbs

TIRE INFLATION

TIRE SIZE	PLY	PSI
11L-15	8	36
12.5L-15	8	36
12.5L-15	12	52
14L-16	12	44
16.5L-16	10	36
19LX16.1	10	32
21.5L-16.1	18	44
11R/22.5	used truck	75
425/65X22.5	used truck	75
28L-26	16	28
550/45X22.5	16	52
600/50X22.5	16	52
600/50X22.5	18	87
700/40X22.5	16	52
700/40X22.5	18	87

Farm Equipment Buyers Trust the Name Meyer!
MEYER SUPER SPREADER
“SPECIFICATIONS”

	Model 2636		Model 3245		Model 3954	
Bushels	260(no ht. ext.)	360(with ht. ext.)	320(no ht. ext.)	450(with ht. ext.)	390(no ht. ext.)	540(with ht. ext.)
Gallon	1355	1745	1694	2189	2033	2617
Cubic Foot	181	233	227	292	272	350
Weight	5300 lbs.	5665 lbs.	6601 lbs.	7020 lbs.	7630 lbs.	8100 lbs.
Overall Height with 14L tire (add 1-1/2 inches for 16.5L tire)	58-1/2" (no ht. ext.)			67-1/2" (with ht. ext.)		
Tank Length	12'		15'		18'	
Overall Width (no tires)	79" single		90-1/2" tandem		90-1/2" tandem	
Overall Width w/14L	84-1/2" single		96" tandem		96" tandem	
Tank Steel - copper bearing	3/16"		3/16"		3/16"	
Frame construction (channel)	8"		8"		8"	
Spindle Size	2-3/4"		2-3/4"		3"	
Hub Size	8 Bolt 6,000 lbs.		8 Bolt 6,000 lbs.		8 Bolt 8,000 lbs.	
Expeller Size	20"		20"		20"	
Expeller Speed	540 RPM		540 RPM		540 RPM	
Auger Speed	10 RPM		10 RPM		10 RPM	
Tractor PTO Speed (Max.)	540 or 1000 RPM (optional)		540 or 1000 RPM (optional)		540 or 1000 RPM (optional)	
Auger Diameter	20"		20"		20"	
Overall Length	18' - 5"		21' - 5"		24' - 5"	
3rd Auger	Optional		Optional		Optional	

MEMBER



Manufactured by:
Meyer Mfg. Corp.

County Hwy. A West
P.O. Box 405
Dorchester, Wisconsin 54425-0405
Phone 715-654-5132 • FAX 715-654-5513
1-800-325-9103



www.meyermfg.com

E-mail: sales@meyermfg.com

Farm Equipment Buyers Trust the Name Meyer!

