



9500 CROP MAX - Specifications • Options

MODEL	9520 Pull Type	9520 Truck Mnt	9524 Pull Type	9524 Truck Mnt	9530 Pull Type	9530 Truck Mount
Box Inside Length	20'	20'	24'	24'	30'	30'
Overall Length	32' 5" w/XTS2400	24' 10" w/gearbox	36' 5" w/XTS3000	28' 10" w/gearbox	42'5" w/XTS4500 600/50	34'10" w/gearbox
Inside Width	90-3/4"	90 3/4"	90-3/4"	90 3/4"	90 3/4"	90 3/4"
Overall Width-Box/Box w/Tires	102"/111"	102"	102"/111"	102"	102"/111"	102"
Inside Height	47-1/2"	47 1/2"	47-1/2"	47 1/2"	47 1/2"	47 1/2"
Overall Height w/S-200	12' 1" w/XTS2400 600/50	8' 4.5" + truck height	12' 1" w/XTS3000 600/50	8' 4.5" + truck height	12' 4.25" w/XTS4500 600/50	8' 4.5" + truck height
Loading Height	9' with trailer	63.5" + truck height	9' with trailer	63.5" + truck height	9' 3.25" with trailer	63.5" + truck height
Capacity Struck/Heaped	600/755 Cu. Ft.	600/755 Cu. Ft.	720/925 Cu. Ft.	720/925 Cu. Ft.	900/1,180 Cu. Ft.	900/1,180 Cu. Ft.
Weight (approximate) w/S-200	17,340# w/600/50x22.5	12,300#	19,760# w/600/50x22.5	13,340#	26,320#	14,900#
Horse Power Required-Min.	200 HP	300 HP + call factory	220 HP	350 HP + call factory	250 HP	400 HP + call factory
Apron Chains	667XH/3-Aprons	667XH/3-Aprons	667XH/3-Aprons	667XH/3-Aprons	667XH/3-Aprons	667XH/3-Aprons
Slats Per Apron	31/93 Per Box	31/93 Per Box	37/111 Per Box	37/111 Per Box	46/138 Per Box	46/138 Per Box
Apron Drive	Hydraulic - Variable	Hydraulic - Variable	Hydraulic - Variable	Hydraulic - Variable	Hydraulic - Variable	Hydraulic - Variable
Floor	Super Slide - Solid Poly	Super Slide - Solid Poly	Super Slide - Solid Poly	Super Slide - Solid Poly	Super Slide - Solid Poly	Super Slide - Solid Poly
Box Sides	Steel - 10 gauge	Steel - 10 gauge	Steel - 10 gauge	Steel - 10 gauge	Steel - 10 gauge	Steel - 10 gauge
Front 36" Folding Guard/Deflect	Standard	Standard	Standard	Standard	Standard	Standard
Transport Lights w/Cord	Standard	Standard	Standard	Standard	Standard	Standard
Reversing Apron Pkg.	Standard	Standard	Standard	Standard	Standard	Standard
Options:	9520 Pull Type	9520 Truck Mnt	9524 Pull Type	9524 Truck Mnt	9530 Pull Type	9530 Truck Mount
Rear Attach S-100/200/300/400	Optional	Optional	Optional	Optional	Optional	Optional
Silage Extension Pkg.	Optional 36"	Optional 36"	Optional 36"	Optional 36"	Optional 36"	Optional 36"
Scale Packages	Optional	Optional	Optional	Optional	Optional	Optional
Nutrient Tracking M.S.	Optional	Optional	Optional	Optional	Optional	Optional
Fender Flare Pkg.	Optional	N/A	Optional	N/A	Optional	N/A

Rear Attachments:	S-100 / Combo	S-200 / Vertical	S-300 / Horizontal	S-400 Grain Hopper
PTO Speed (RPM)	1000 RPM	1000 RPM	1000 RPM	
PTO Protection Cutout Style	Standard	Standard	Standard	Quick Detach Hopper
Automatic Clutch				
Vertical Expeller Diameter	N/A	44"	N/A	
Fighting Thickness	N/A	1/2"	N/A	
Horizontal Beater	2 Standard	N/A	4 Beater Standard	With Grain Door
Expeller/Beater Speed	400 RPM - Lower Disks	400 RPM	388 RPM	
Tips/Paddles-Replaceable	AR400	AR400	AR400	
Gate Style	Guillotine Style Standard	Swing Arm Style	Swing Arm Style	
	Swing Arm Style Optional			

	For 9520	*For 9524*	*For 9530*
Trailers (pull type)	XTSW2400	XTSW3000	XTSW4500
Frame	4x8 tubing	4x8 tubing	4x8 tubing
Capacity (trailer/spreader/load)	48,000#	60,000#	90,000#
Axle Configuration	Tandem - non steer	Tandem - non steer - Std.	Tridem - steerable
	25,000# x 2 - high speed-ag	30,000# x 2 - high speed-ag	33,000# x 3 - high speed-ag
	Fixed Spring Suspension	Sliding Spring Suspension	Fixed Spring Suspension
Hub	Oil Bath - 10 Bolt	Oil Bath - 10 Bolt	10 Bolt
Articulating Implement Hitch	Std. - Requires 1.5" or 2" pin Hammerstrap style hitch	Std. - Requires 1.5" or 2" pin Hammerstrap style hitch	Std. - Requires 1.5" or 2" pin Hammerstrap style hitch
Tire Options:	600/50 or 700/40 HD high floatation 425/65x22.5 new truck tires	600/50 or 700/40 HD high floatation 425/65x22.5 new truck tires	600/50 or 700/40 HD high floatation 425/65x22.5 new truck tires
	11Rx22.5 new, dual truck tires	11Rx22.5 new, dual truck tires	11Rx22.5 new, dual truck tires
Brakes (air, hyd or foot pedal)	Optional	Optional	Optional-no air option
Track Undercarriage	2400 - Optional	3000 - Optional	4500 - Optional
Safety Chain	Optional	Optional	Optional

Make the most of your CROP MAX... Grain Hopper Attachment



**American Made American
Owned for 65 years**

YOUR DEALER IS:

Model & Specifications subject to change without notice or obligation.

Large Capacity Industrial Series

9500 "Crop Max" Spreader



**Over
65 years
of service
to our customers**



9530 w/S-200 Vertical
1,500 bushel

9524 Truck Mount
w/S-200 Vertical

9520 w/S-200 Vertical
1,000 bushel

9524 w/S-100 Combo
1,200 Bushel

S-200 Vertical Pattern

S-100 Combination Pattern

**Compost • Dry Feed Lot • Pen Packed
Sludge Products • Poultry Litter
Separator Solids • Digester Solids • More**



Farm Equipment Buyers Trust The Name Meyer!

Meyer Mfg. Corp. • Dorchester, Wisconsin 54425 • 715/654-5132 • FAX: 715/654-5513

1-800-325-9103

email: sales@meyermfg.com • home page: www.meyermfg.com



Farm Equipment Buyers Trust The Name Meyer!



REAR ATTACHMENT OPTIONS:
ALL 3 ATTACHMENTS ARE DIRECT DRIVEN
 (except semi-trailer mounted)
TO MAINTAIN CONSISTENT SPREAD PATTERNS BEGINNING TO END
No Hydraulic Stalls or Variations in Rate!

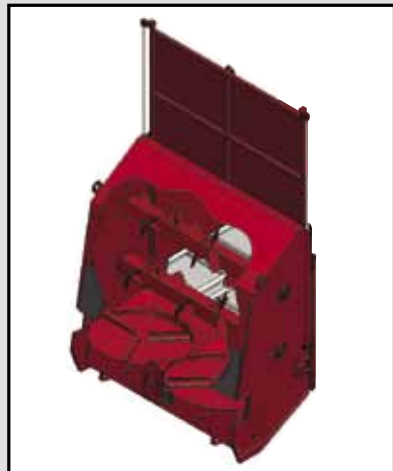

S-100
 < Combination Design of 2 horizontal beaters with lower spinner disks to disperse material. Patterns will be low and wide – up to 65'. Ideal for litter, compost and digester solids, capable of handling bedding pack and lime products. (Guillotine tailgate standard, swing arm opt.)



S-200
 < Massive, Dual Vertical Expellers (44" diameter) creating an explosive 30-40 foot pattern. Versatile due to its ability to handle most types of manure, sludge and compost including frozen, dry feedlot and packed manure! (Swing arm tailgate standard w/belting deflector kit)

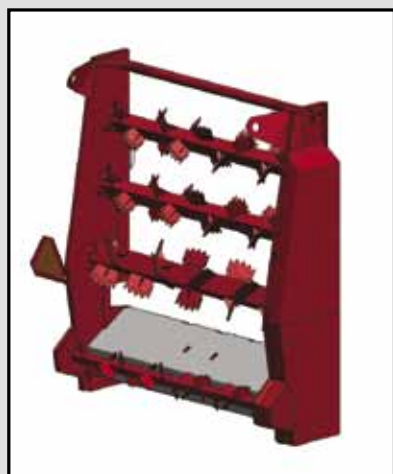

S-300
 < A conventional Horizontal Beater Design with 3 or 4 beaters. Capable of handling most materials with a consistent pattern about 9-12' wide. Standard 4th beater eliminates chunks falling off the aprons. (Swing arm tailgate standard)

ALL ATTACHMENTS ARE EASILY REMOVABLE AND INTERCHANGABLE!

The Swing Arm Style Tailgate also features a Bypass Valve for your protection. The apron will not operate until the tailgate is in the fully open position. This feature protects your spreader and limits the hydraulic outlet requirements on your tractor!

The PTO Driveline features a standard constant velocity - 1 3/4" 20 spline yoke, over-running clutch and torque disconnect clutch to protect your expeller drive system. The pto bearing tower is rubber mounted to reduce vibration.

Solid-poly floor with Triple 667XH Aprons – 180,000# combined tensile! **Variable Speed Apron Drive** is Standard on all Models!

Massive formed channel floor supports. Only 7" gap between supporting crossmembers!

9524 pictured with XTSW3000 Trailer
 XTSW 3000 features a sliding axle system to match drawbar weight and maneuverability when converting to silage box.



Silage Extension Package
 Adds 36" additional height

*utilizes spreader tailgate when equipped with swing-arm tailgate.
 *top pivot rear door available for spreaders equipped with guillotine gate.
 (pictured with non-current eyebrow fenders)

This Belting Deflector is standard equipment with the swing arm tailgate. It reduces kickback of rocks and frozen manure when using the vertical attachment.

Hinged Stake System for easy attachment removal. As you lift on the upper lift tabs, the attachment hinges out and lifts out of the stakes.

High-Efficiency Berma 800 Series apron gearbox to pull the load. This gear-to-gear design is simple and strong! It is outfitted with the Meyer Hydraulic Variable Speed Control.

Massive Expeller Driveline features a center drive design for reduced stress. (S-100 / S-200)
 Massive bevel gearbox design makes others look small!

Attachment Driveline
 No-Tool disconnection!
 Unhooks just like a tractor PTO.



9524 Truck Mount w/Silage Conversion
 The "Crop Max" offers versatility and capacity the others just can't match!

Contact factory for truck requirements



XTSW4500 – 45 ton Tridem – Steerable

Wide-Track Suspension Style Trailers
 XTSW2400 / 3000 / 4500 – 24, 30, 45 Ton Capacity
 Spring Suspensions – All Models / Oil Bath Hubs - XTSW2400 & 3000
 Tire options include 600/50, 700/40 floatation or dual/single Truck Style
 Sliding Axle System standard on XTSW3000
 Fixed on XTSW2400 & 4500



XTSW3000 – 30 ton Tandem w/Slider



Articulating Implement Hitch
 Standard Equipment on XTS trailers.
 Pivots with your drawbar to minimize wear and stress!
 Requires hammerstrap drawbar w/1.5 or 2" pin.



Scale Packages Available Maximize the Value of Your Material
 6 and 8 point models depending on box size. Load cells mounted between box and chassis for accurate performance.
Nutrient Tracking Management System
 with on-the-go application rates and GPS coordinate data.
 Also Available – Hydraulic Speed Sensor Port for Variable Rate Applications! (Optional)